



UNIVERSITY OF CAMBRIDGE INTERNATIONAL EXAMINATIONS  
International General Certificate of Secondary Education

CANDIDATE  
NAME

CENTRE  
NUMBER

--	--	--	--	--

CANDIDATE  
NUMBER

--	--	--	--

**Biology**

**0610/53**

Paper 5 Practical Test

**May/June 2012**

**1 hour 15 minutes**

Candidates answer on the Question Paper

Additional Materials: As listed in the Confidential Instructions

**READ THESE INSTRUCTIONS FIRST**

Write your Centre number, candidate number and name on all the work you hand in.

Write in dark blue or black pen.

You may use a pencil for any diagrams or graphs.

Do not use staples, paper clips, highlighters, glue or correction fluid.

DO **NOT** WRITE IN ANY BARCODES.

Answer **both** questions.

At the end of the examination, fasten all your work securely together.

The number of marks is given in brackets [ ] at the end of each question or part question.

For Examiner's Use	
1	
2	
<b>Total</b>	

This document consists of **11** printed pages and **1** blank page.



Read through all the questions on this paper carefully before starting work.  
You may need to spend more time on Question 1.

For  
Examiner's  
Use

- 1 Some animals have an outer layer of fur or feathers which helps to keep their internal body temperature constant.

You are going to investigate the effect of an outer layer on the cooling rate of water in test-tubes.

- test-tube **A** – leave uncovered  
Label this test-tube 2 cm from the top, **A**.
- test-tube **B** – cover with two layers of paper towel  
Secure the covering with two elastic bands, as shown in Fig. 1.1.  
Label this test-tube 2 cm from the top, **B**.

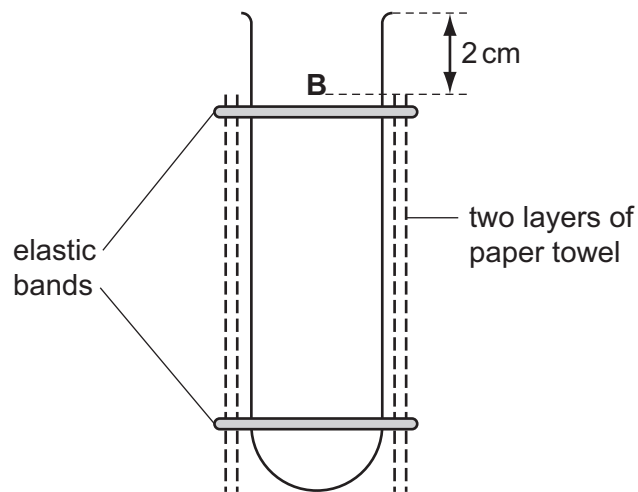

Fig. 1.1

You are going to measure the temperature of water in test-tubes **A** and **B** over 10 minutes. You must read and record the temperature at 0 (start), 2, 4, 6, 8 and 10 minutes.

For  
Examiner's  
Use

(a) (i) Construct a suitable table in which to record your results.

[4]

**When you have reached this stage, raise your hand for the Supervisor to bring you a beaker of hot water.**

(ii)

- Carefully fill both test-tubes with hot water, up to the letter label.
- Place the thermometer in test-tube **A** and read the starting temperature. Write this in your table.  
Start timing.
- Immediately place the thermometer into test-tube **B** and read the starting temperature. Write this in your table.
- Place the thermometer back into test-tube **A**.
- At 2 minutes, read the temperature and write this in your table.
- Immediately place the thermometer in test-tube **B** and read the temperature. Write this in your table.
- Repeat this process at 4, 6, 8 and 10 minutes.

[3]

- (iii) Construct a graph using your results, to compare the cooling of the water in test-tubes **A** and **B**.

For  
Examiner's  
Use

Use the same axes for both test-tubes.

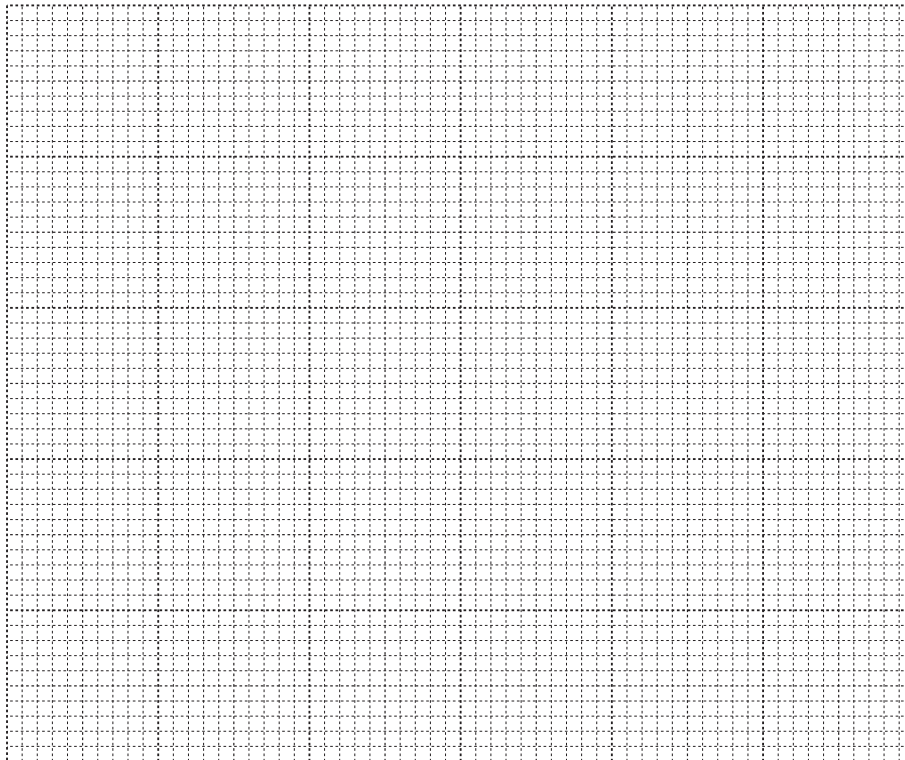

[5]

- (b) Describe **and** explain your results for test-tubes **A** and **B**.

.....

.....

.....

.....

.....

.....

.....

[3]

(c) State **two** sources of error in the **method** of this investigation.  
Suggest how to improve the method to reduce **each** source of error.

For  
Examiner's  
Use

source of error .....

.....

improvement .....

.....

source of error .....

.....

improvement .....

..... [4]

(d) A student repeated this investigation in a room at 25°C.  
Predict the temperature of the water in test-tubes **A** and **B** after one hour.

temperature ..... °C [1]

Fig. 1.2 shows a section through the skin of a mammal, as seen through a microscope.

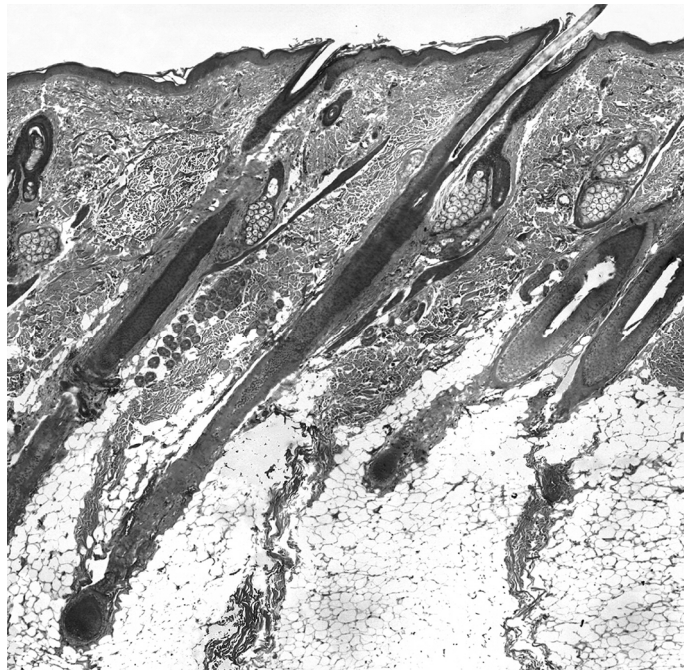

Fig. 1.2

Fig. 1.3 shows a drawing of this section.

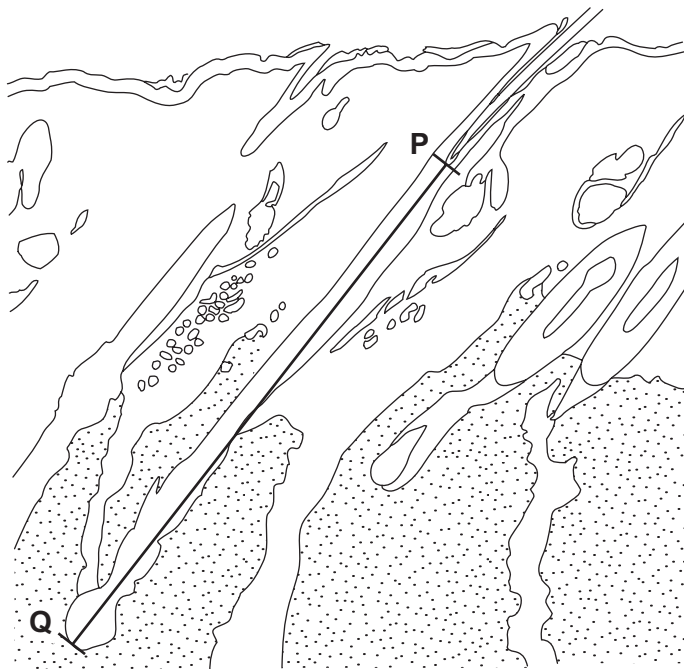

Fig. 1.3

For  
Examiner's  
Use

(e) On Fig. 1.3 draw a line and label each of the following structures:

- hair follicle
- fatty tissue

[2]

(f) (i) Measure the length of line **PQ** on Fig. 1.3.

**PQ** .....mm [1]

(ii) On the microscope slide, the actual length of line **PQ** was 4 mm.

Calculate the magnification of Fig. 1.3.

Show your working.

magnification ..... [2]

*For  
Examiner's  
Use*

(g) When the body temperature is raised sweat is released from sweat glands to the surface of the skin.

*For  
Examiner's  
Use*

Describe how you could test for the presence of water in sweat.

.....  
.....  
.....  
..... [2]

[Total: 27]



2 You are provided with a flower in a beaker of water.

- Remove the petals one at a time.
- Put the central reproductive structures on the white tile. You will need them for **(b)**.
- Place each petal in the space below.
- Draw around each petal.
- Use the hand lens to examine the petals.
- Record any detail you observe.

**(a)**

*For  
Examiner's  
Use*

[3]

(b) Make a large drawing of the central reproductive structures.

Label the stigma **and** style.

For  
Examiner's  
Use

[4]

(c) Describe **one** visible feature that shows the flower is insect-pollinated.

.....

.....

[1]

(d) State the part of the reproductive structures which become

the seed, .....

the fruit. .... [2]

(e) Describe how a typical wind-pollinated flower is different from a typical insect-pollinated flower.

.....  
.....  
.....  
.....  
.....  
.....  
..... [3]

[Total: 13]

**BLANK PAGE**

---

Permission to reproduce items where third-party owned material protected by copyright is included has been sought and cleared where possible. Every reasonable effort has been made by the publisher (UCLES) to trace copyright holders, but if any items requiring clearance have unwittingly been included, the publisher will be pleased to make amends at the earliest possible opportunity.

University of Cambridge International Examinations is part of the Cambridge Assessment Group. Cambridge Assessment is the brand name of University of Cambridge Local Examinations Syndicate (UCLES), which is itself a department of the University of Cambridge.