



UNIVERSITY OF CAMBRIDGE INTERNATIONAL EXAMINATIONS  
International General Certificate of Secondary Education

CANDIDATE  
NAME

CENTRE  
NUMBER

|  |  |  |  |  |
|--|--|--|--|--|
|  |  |  |  |  |
|--|--|--|--|--|

CANDIDATE  
NUMBER

|  |  |  |  |
|--|--|--|--|
|  |  |  |  |
|--|--|--|--|



\* 5 3 1 0 0 8 0 2 4 \*

**CHEMISTRY**

**0620/22**

Paper 2

**October/November 2010**

**1 hour 15 minutes**

Candidates answer on the Question Paper.

No Additional Materials are required.

**READ THESE INSTRUCTIONS FIRST**

Write your Centre number, candidate number and name in the spaces at the top of this page.

Write in dark blue or black pen.

You may need to use a pencil for any diagrams, graphs or rough working.

Do not use staples, paper clips, highlighters, glue or correction fluid.

**DO NOT WRITE IN ANY BARCODES.**

Answer **all** questions.

A copy of the Periodic Table is printed on page 16.

At the end of the examination, fasten all your work securely together.

The number of marks is given in brackets [ ] at the end of each question or part question.

| For Examiner's Use |  |
|--------------------|--|
| 1                  |  |
| 2                  |  |
| 3                  |  |
| 4                  |  |
| 5                  |  |
| 6                  |  |
| 7                  |  |
| <b>Total</b>       |  |

This document consists of **15** printed pages and **1** blank page.



1 Choose from the following list of oxides to answer the questions below.  
You can use each oxide once, more than once or not at all.

- carbon dioxide
- carbon monoxide
- magnesium oxide
- nitrogen dioxide
- sulfur dioxide
- water

(a) Which **one** of these oxides is a basic oxide?  
..... [1]

(b) Which **two** oxides cause acid rain?  
..... and ..... [2]

(c) Which **two** oxides are formed when a hydrocarbon undergoes complete combustion?  
..... and ..... [2]

(d) Which **one** of these oxides turns white copper(II) sulfate blue?  
..... [1]

(e) Which oxide is formed when calcium carbonate undergoes thermal decomposition?  
..... [1]

[Total: 7]

2 The diagram shows the structure of some compounds containing iodine.

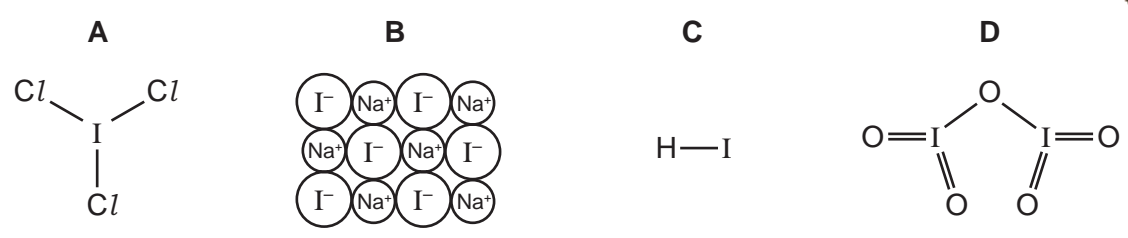

(a) (i) What do you understand by the term *compound*?  
 .....  
 ..... [1]

(ii) Which **one** of these compounds, **A**, **B**, **C** or **D**, has a high melting point?  
 Explain your answer.  
 compound .....  
 explanation ..... [2]

(iii) Which **one** of these compounds is similar in structure to hydrogen chloride?  
 ..... [1]

(b) Compound **B** is sodium iodide.

(i) Which statement about the electrical conductivity of sodium iodide is correct?  
 Tick **one** box.

- It conducts electricity when molten.
  - It conducts electricity when solid.
  - It does not conduct electricity when molten.
  - It does not conduct electricity in aqueous solution.
- [1]

(ii) Describe a test for iodide ions.  
 test .....  
 result ..... [2]

(c) Compound **D** is iodine(V) oxide. It is an acidic oxide.  
 Suggest why iodine(V) oxide is an acidic oxide.  
 ..... [1]

3 Some properties of the Group I elements are given in the table.

| element   | melting point / °C | boiling point / °C | density in g/cm <sup>3</sup> |
|-----------|--------------------|--------------------|------------------------------|
| lithium   | 181                | 1342               | 0.53                         |
| sodium    | 98                 | 883                | 0.97                         |
| potassium | 63                 |                    | 0.86                         |
| rubidium  | 39                 | 686                | 1.53                         |
| caesium   | 29                 | 669                | 1.88                         |

(a) (i) Predict the boiling point of potassium.

..... [1]

(ii) Which Group I elements are liquids at 50 °C?

..... [2]

(iii) How, in general, does the density of the Group I elements change down the group?

..... [1]

(b) Complete the following sentences about the Group I elements using words from the list below.

- crystallising
- decreases
- hard
- increases
- melting
- similarity
- soft

The Group I elements are relatively ..... metals which show a trend in ..... point and reaction with water.

The reactivity with water ..... down the group. [3]

(c) The equation for the reaction of sodium with water is given below.

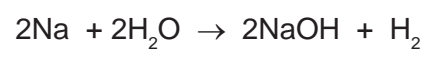

Write a word equation for this reaction.

(d) Chlorine reacts with sodium to form sodium chloride.

(i) Complete the equation for this reaction.

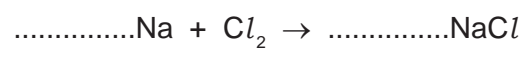

[2]

(ii) Chlorine is a diatomic gas.  
What do you understand by the term *diatomic*?

..... [1]

(iii) Describe the arrangement and motion of the molecules in chlorine gas.

arrangement .....

motion ..... [2]

(iv) Draw a diagram to show the arrangement of the electrons in a molecule of chlorine.  
Show only the outer electrons.

[2]

[Total: 16]

4 The formulae of four organic compounds are shown below.

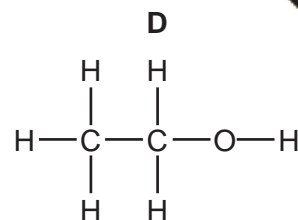
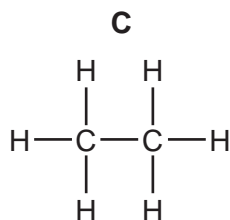
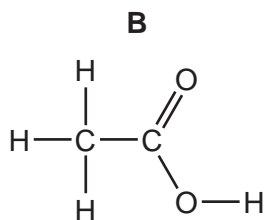
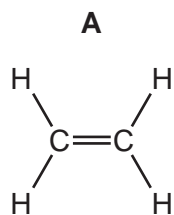

(a) (i) State the name of the type of bonding between the atoms in these four compounds.

..... [1]

(ii) Which **one** of these compounds, **A**, **B**, **C** or **D**, is a saturated hydrocarbon?

..... [1]

(iii) Which **one** of these compounds is acidic?

..... [1]

(iv) State the name of compound **D**.

..... [1]

(v) Compound **A** contains a C=C double bond.  
Describe a test for a C=C double bond.

test .....

result ..... [2]

(b) Compound **C** is a member of the alkane homologous series.

(i) State **two** features of an homologous series.

1. ....

2. .... [2]

(ii) State the formula and name of another alkane in the same homologous series as compound **C**.

formula

name ..... [2]

(c) The alkanes present in petroleum can be separated by fractional distillation. The diagram below shows a fractional distillation column.

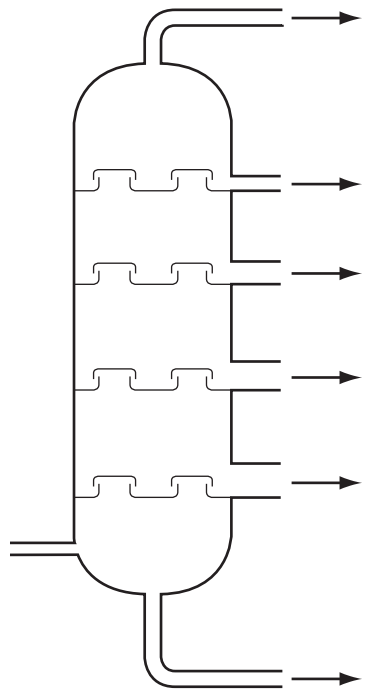

- (i) On the diagram, label where the temperature in the column is the lowest. Mark this with the letter **X**. [1]
- (ii) On the diagram, label where the bitumen fraction is collected. Mark this with the letter **Y**. [1]

[Total: 12]

5 A student used the apparatus shown below to investigate the speed of reaction when lumps of zinc reacted with excess sulfuric acid.

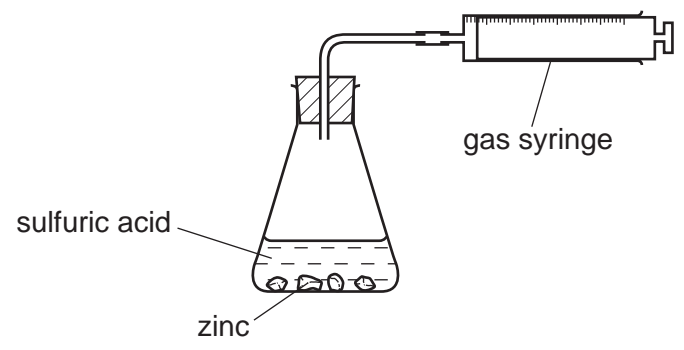

(a) As the reaction proceeds, describe what happens to

(i) the mass of the zinc lumps.

..... [1]

(ii) the concentration of zinc sulfate in the solution in the flask.

..... [1]



(b) The student's results are shown below.

|                                      |   |    |    |    |    |    |    |
|--------------------------------------|---|----|----|----|----|----|----|
| time / minutes                       | 0 | 10 | 20 | 30 | 40 | 50 | 60 |
| volume of hydrogen / cm <sup>3</sup> | 0 | 24 | 39 | 48 | 53 | 55 | 55 |

(i) Plot a graph of volume of hydrogen against time. Use the axes below.

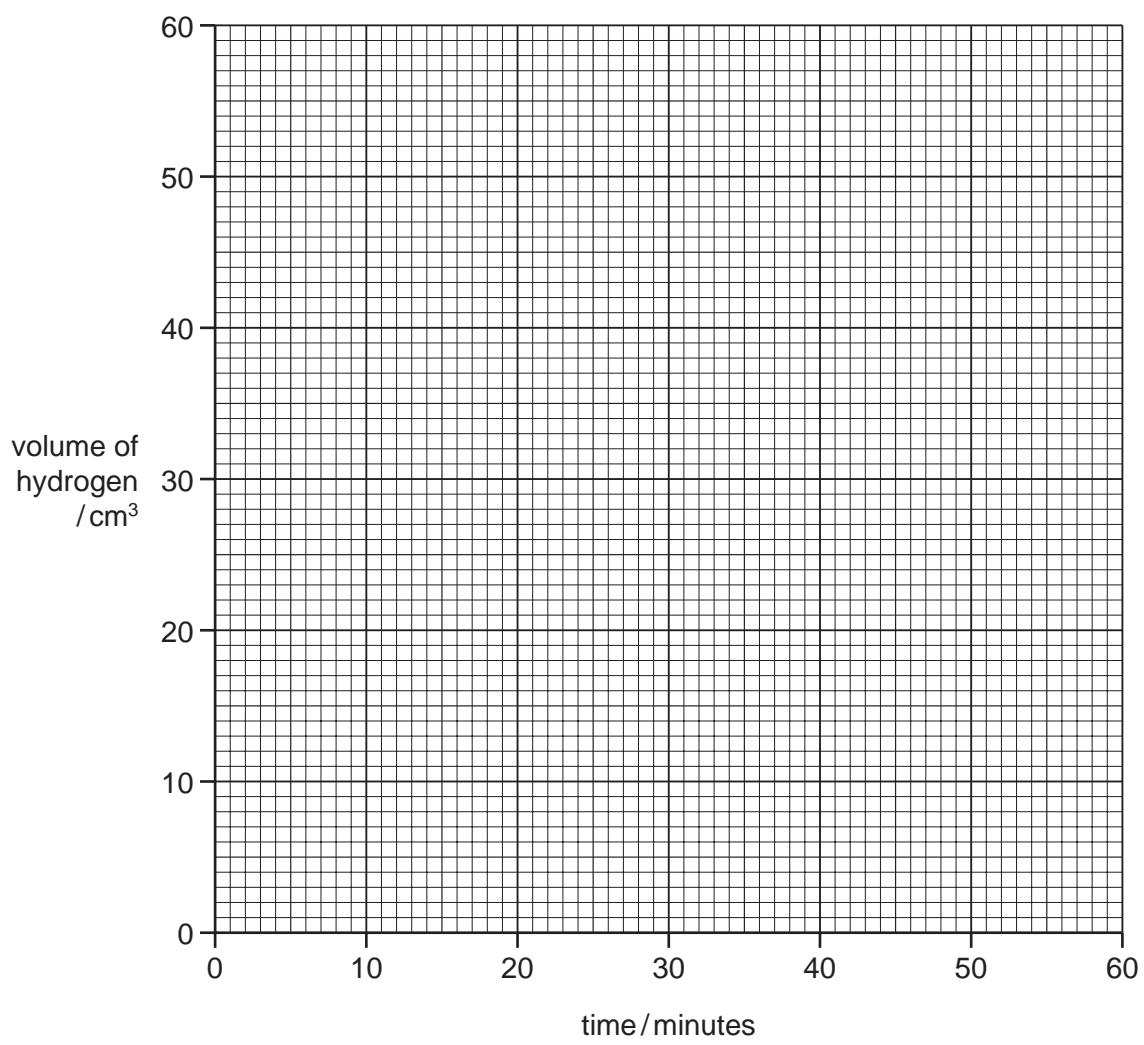

[3]

(ii) Use your graph to calculate the volume of hydrogen given off after 25 minutes.

volume of hydrogen ..... [1]

(iii) Explain why no more hydrogen was given off after 50 minutes.

..... [1]

(iv) Describe a test for hydrogen.

test .....

result ..... [2]

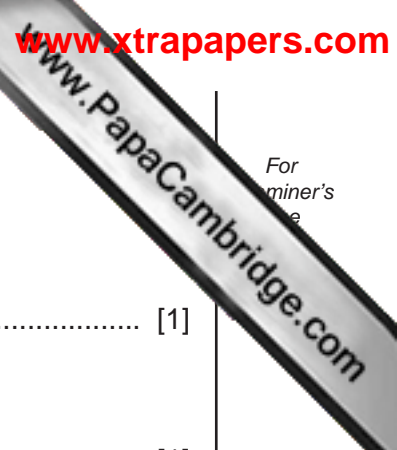

For  
miner's  
e

(c) What happens to the speed of the reaction when

(i) smaller pieces of zinc are used?

..... [1]

(ii) some water is added to the sulfuric acid?

..... [1]

(d) The reaction between zinc and sulfuric acid is catalysed by copper(II) sulfate solution. What do you understand by the term *catalyst*?

..... [1]

[Total: 12]

6 Iron is a transition element.

(a) State **three** properties of transition elements which are not shown by the Group elements.

- 1. ....
- 2. ....
- 3. .... [3]

(b) The symbols for two isotopes of iron are shown below.



- (i) How do these two isotopes differ in their atomic structure?  
..... [1]
- (ii) State the number of nucleons present in one atom of the isotope  ${}_{26}^{57}\text{Fe}$ .  
..... [1]
- (iii) How many electrons are there in one atom of the isotope  ${}_{26}^{54}\text{Fe}$ ?  
..... [1]

(c) Pure iron rusts very easily.

- (i) State the **two** conditions that are needed for rusting to take place.
  - 1. ....
  - 2. .... [2]
- (ii) Describe and explain **one** method of preventing rusting.
 

method .....

explain why this method works .....

..... [2]

(d) In the blast furnace, iron(III) oxide reacts with carbon monoxide.

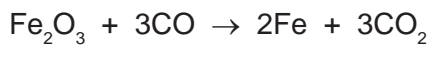

Which substance gets reduced in this reaction?  
Explain your answer.

substance .....

explanation .....

..... [2]

(e) (i) Carbon monoxide is a pollutant gas produced in motor car engines.  
Explain why carbon monoxide is formed.

..... [1]

(ii) State **one** harmful effect of carbon monoxide.

..... [1]

[Total: 14]

7 Boric acid is an acid. Urea is a base. Both compounds are crystalline. A student placed some crystals of boric acid and urea in a large beaker of water. The value of the water at the start of the experiment was pH 7.

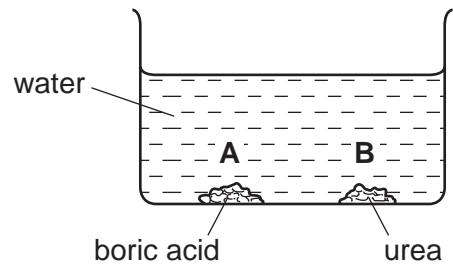

(a) After 15 minutes the pH at point A in the beaker was pH 6.2.

(i) Suggest why the pH at point A had decreased.

..... [1]

(ii) What was the most likely pH at point B in the beaker after 15 minutes? Put a ring around the correct answer.

**pH 1**                  **pH 6**                  **pH 7**                  **pH 8**                  [1]

(iii) The particles of boric acid and urea diffuse throughout the solution. What do you understand by the term *diffusion*?

.....  
..... [1]

(iv) After 24 hours the pH throughout the whole solution was pH 7. Use your knowledge of acids and alkalis to explain why the pH returned to pH 7.

.....  
..... [1]

(b) The structure of urea is shown below.

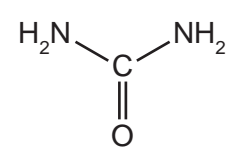

(i) Write the simplest formula for urea.

[1]

(ii) Calculate the relative molecular mass of urea.  
Use your Periodic Table to help you.

[1]

(c) Urea is used as a fertiliser.

(i) Which element present in urea is an essential part of most fertilisers?

..... [1]

(ii) Explain why farmers put fertilisers on their fields.

.....  
..... [2]

(d) Describe how you can obtain pure, dry crystals of urea from an aqueous solution of urea.

.....  
.....  
..... [2]

[Total: 11]



