



Cambridge IGCSE™

COMPUTER SCIENCE

0478/12

Paper 1

February/March 2022

MARK SCHEME

Maximum Mark: 75

Published

This mark scheme is published as an aid to teachers and candidates, to indicate the requirements of the examination. It shows the basis on which Examiners were instructed to award marks. It does not indicate the details of the discussions that took place at an Examiners' meeting before marking began, which would have considered the acceptability of alternative answers.

Mark schemes should be read in conjunction with the question paper and the Principal Examiner Report for Teachers.

Cambridge International will not enter into discussions about these mark schemes.

Cambridge International is publishing the mark schemes for the February/March 2022 series for most Cambridge IGCSE™, Cambridge International A and AS Level components and some Cambridge O Level components.

This document consists of **13** printed pages.

PUBLISHED**Generic Marking Principles**

These general marking principles must be applied by all examiners when marking candidate answers. They should be applied alongside the specific content of the mark scheme or generic level descriptors for a question. Each question paper and mark scheme will also comply with these marking principles.

GENERIC MARKING PRINCIPLE 1:

Marks must be awarded in line with:

- the specific content of the mark scheme or the generic level descriptors for the question
- the specific skills defined in the mark scheme or in the generic level descriptors for the question
- the standard of response required by a candidate as exemplified by the standardisation scripts.

GENERIC MARKING PRINCIPLE 2:

Marks awarded are always **whole marks** (not half marks, or other fractions).

GENERIC MARKING PRINCIPLE 3:

Marks must be awarded **positively**:

- marks are awarded for correct/valid answers, as defined in the mark scheme. However, credit is given for valid answers which go beyond the scope of the syllabus and mark scheme, referring to your Team Leader as appropriate
- marks are awarded when candidates clearly demonstrate what they know and can do
- marks are not deducted for errors
- marks are not deducted for omissions
- answers should only be judged on the quality of spelling, punctuation and grammar when these features are specifically assessed by the question as indicated by the mark scheme. The meaning, however, should be unambiguous.

GENERIC MARKING PRINCIPLE 4:

Rules must be applied consistently, e.g. in situations where candidates have not followed instructions or in the application of generic level descriptors.

GENERIC MARKING PRINCIPLE 5:

Marks should be awarded using the full range of marks defined in the mark scheme for the question (however; the use of the full mark range may be limited according to the quality of the candidate responses seen).

GENERIC MARKING PRINCIPLE 6:

Marks awarded are based solely on the requirements as defined in the mark scheme. Marks should not be awarded with grade thresholds or grade descriptors in mind.

Question	Answer	Marks
1(a)	85	1
1(b)	C0	1
1(c)	26	1
1(d)	16	1

Question	Answer	Marks
2(a)	e.g. JPEG	1
2(b)	Any three from: <ul style="list-style-type: none"> Image is made of pixels Each pixel stores one colour Image has a set number of pixels wide by pixels high Each colour has a unique binary value // Each colour has a unique colour code The colour/binary value of each pixel is stored in sequence File contains metadata to identify how the file should be displayed ... metadata can be the colour depth / resolution 	3
2(c)(i)	Reducing the file size	1
2(c)(ii)	Any two from: <ul style="list-style-type: none"> reduces the storage/memory space taken on email server // reduces the storage space taken on her friend's computer when downloaded sending/receiving email accounts may have restricted file size for attachments reduces the time taken to transmit/upload/download to destination reduces amount of bandwidth needed to transmit/download file will mean less data usage is taken (for mobile clients) 	2

Question	Answer	Marks
2(c)(iii)	Any five from: <ul style="list-style-type: none"> • Parity can be set to odd or even • Sender and receiver agree on parity to use • Data/email/image is split into bytes // blocks of 7 bytes • Sender counts the number of 1s/0s in each group/byte • Each group/byte is assigned a parity bit to match the parity/odd/even • Receiving device/server counts the number of 1s/0s in each group/byte • ... and compares to parity used/odd/even and if it does not match the parity, an error is reported/identified • (in block check) the location of the error(s) can be identified/estimated at the intersection 	5
2(c)(iv)	1 mark for identification Any three for corresponding description: <ul style="list-style-type: none"> • Checksum • Value is calculated from the data ... • ...using an algorithm // by example • Value is transmitted with the data • Value recalculated by receiver (using same algorithm) ... • ...if checksum values are different there is an error // reverse • Automatic Repeat request/reQuery (ARQ) • Uses acknowledgement and timeout • Sender starts a timer when data is transmitted • Receiver uses an error checking method to check whether the data has been received accurately • If no error detected a positive acknowledgement is returned to sender • If error detected negative acknowledgement is returned to sender • If sender gets no acknowledgement within the set time it resends the data 	4

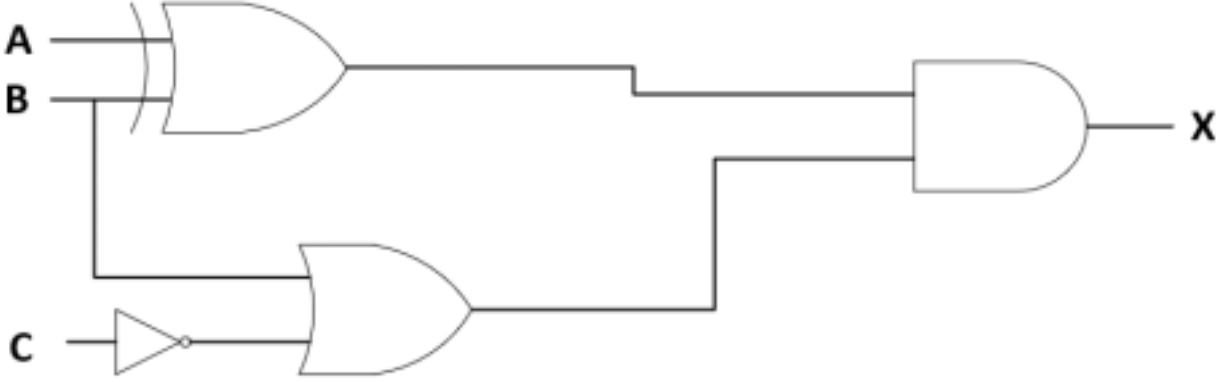
Question	Answer	Marks																								
3(a)	1 mark per row <table border="1" data-bbox="616 248 1659 614"> <thead> <tr> <th>Inputs</th> <th>AND</th> <th>OR</th> <th>NAND</th> <th>NOR</th> <th>XOR</th> </tr> </thead> <tbody> <tr> <td>A = 1 B = 1</td> <td>✓</td> <td>✓</td> <td></td> <td></td> <td></td> </tr> <tr> <td>A = 0 B = 0</td> <td></td> <td></td> <td>✓</td> <td>✓</td> <td></td> </tr> <tr> <td>A = 1 B = 0</td> <td></td> <td>✓</td> <td>✓</td> <td></td> <td>✓</td> </tr> </tbody> </table>	Inputs	AND	OR	NAND	NOR	XOR	A = 1 B = 1	✓	✓				A = 0 B = 0			✓	✓		A = 1 B = 0		✓	✓		✓	3
Inputs	AND	OR	NAND	NOR	XOR																					
A = 1 B = 1	✓	✓																								
A = 0 B = 0			✓	✓																						
A = 1 B = 0		✓	✓		✓																					
3(b)	1 mark per gate  <ul data-bbox="338 1214 593 1353" style="list-style-type: none"> • A XOR B • NOT C • (NOT C) OR B • AND 	4																								

Question	Answer	Marks
4(a)(i)	<p>1 mark for each completed statement</p> <p>An optical mouse shines a red light from a Light-Emitting Diode//LED underneath the mouse. The light reflects back from a surface through a lens in the mouse and is converted to a value. This value is transmitted to the computer. The computer then determines the direction and speed of the movement.</p> <p>When the user presses a key on a keyboard, the key pushes the switch on the circuit board. This completes a circuit. Signals are sent to the computer that uses the data to calculate which key was pressed.</p>	6
4(a)(ii)	<p>1 mark each e.g.</p> <ul style="list-style-type: none"> • touchscreen • touchpad • scanner • microphone 	2
4(b)	<p>Any three from:</p> <ul style="list-style-type: none"> • More visible pixels // higher resolution • Higher colour contrast (in ambient lighting) // more vivid colours • Colours are (often) more accurate • Image (usually) appears brighter (with same wattage) • Will be stationary so does not need the portability of DLP • Does not need the compactness of DLP • Cost of purchase (usually) less • Run quieter • Any surface can be used as a display • Uses less power • Produces less heat • Does not give the rainbow effect DLP often gives • Longer lasting lamps 	3

Question	Answer	Marks
4(c)	<p>1 mark for naming appropriate device</p> <ul style="list-style-type: none"> • hard disk / HDD / magnetic • solid state drive / SSD / USB memory stick / flash drive <p>1 mark each for matching justification to max 3. e.g.</p> <p>HDD</p> <ul style="list-style-type: none"> • Large capacity storage • ...for videos/films that have large file sizes / require large storage space • Longevity // Can be read from/written to large number of times • ... the copies will be accessible for a long time // device will not break if accessed regularly • ...may require large number of read/write to access fields • Relatively cheap per GB // cheaper than SSD per GB ... • ... there is a large capacity required therefore overall may cost less than other devices • Device will not be moved regularly so no need for portability/durability <p>SSD</p> <ul style="list-style-type: none"> • Large capacity storage • ...for videos/films that have large file sizes / require large storage space • No moving parts • ...can be carried/moved to other locations with limited risk of damage • Fast access speed • ... videos are large files that will be stored/accessed in less time • Cost per GB is not significant (in comparison) • ...there is a large capacity required therefore overall cost will not be significantly more than others • Used as a copy of files to may not be accessed regularly • ... the limited number of read/write times/longevity is inconsequential • Uses less power // runs cooler • No latency // does not take time to start-up 	4

Question	Answer	Marks
5(a)	<p>1 mark for each example, allow description or tags</p> <p>Structure e.g.</p> <ul style="list-style-type: none">• head• body• table• heading• subheading• paragraph• object position on the page // alignment• margins• borders (position/size)• padding <p>Presentation e.g.</p> <ul style="list-style-type: none">• colour• font size• font style• border (style)	4

Question	Answer	Marks								
5(b)	<p>1 mark for each bullet to max 2 for each</p> <table border="1" data-bbox="421 248 1854 1402"> <thead> <tr> <th data-bbox="421 248 723 312">Type of address</th> <th data-bbox="723 248 1854 312">Features</th> </tr> </thead> <tbody> <tr> <td data-bbox="421 312 723 528">URL</td> <td data-bbox="723 312 1854 528"> <ul style="list-style-type: none"> • protocol • domain name • top level domain • file/folder name/address/directory/path • made up of letters, numbers and symbols </td> </tr> <tr> <td data-bbox="421 528 723 1086">IP</td> <td data-bbox="723 528 1854 1086"> <p>IPv4:</p> <ul style="list-style-type: none"> • 4 groups of numbers // 12 numbers • separated by full stops (.) • 0-255 in each group • 4 bytes long // 32 bits • Represented in denary <p>IPv6:</p> <ul style="list-style-type: none"> • 8 groups of numbers // 32 numbers • separated by colons (:) • 0-FFFF in each group • 16 bytes long // 128 bits • Consecutive groups of 0000 can be replaced with :: • Represented in hexadecimal </td> </tr> <tr> <td data-bbox="421 1086 723 1402">MAC</td> <td data-bbox="723 1086 1854 1402"> <ul style="list-style-type: none"> • First part is manufacturer ID • Second part is serial number • Each part has 3 pairs of numbers // Each part has 6 numbers // 6 pairs of 2-digits // consists of 12 numbers • ...between 00 and FF • ..separated by : • Each part is 3 bytes // Is 6 bytes long // Is 48 bits long • Represented using hexadecimal </td> </tr> </tbody> </table>	Type of address	Features	URL	<ul style="list-style-type: none"> • protocol • domain name • top level domain • file/folder name/address/directory/path • made up of letters, numbers and symbols 	IP	<p>IPv4:</p> <ul style="list-style-type: none"> • 4 groups of numbers // 12 numbers • separated by full stops (.) • 0-255 in each group • 4 bytes long // 32 bits • Represented in denary <p>IPv6:</p> <ul style="list-style-type: none"> • 8 groups of numbers // 32 numbers • separated by colons (:) • 0-FFFF in each group • 16 bytes long // 128 bits • Consecutive groups of 0000 can be replaced with :: • Represented in hexadecimal 	MAC	<ul style="list-style-type: none"> • First part is manufacturer ID • Second part is serial number • Each part has 3 pairs of numbers // Each part has 6 numbers // 6 pairs of 2-digits // consists of 12 numbers • ...between 00 and FF • ..separated by : • Each part is 3 bytes // Is 6 bytes long // Is 48 bits long • Represented using hexadecimal 	6
Type of address	Features									
URL	<ul style="list-style-type: none"> • protocol • domain name • top level domain • file/folder name/address/directory/path • made up of letters, numbers and symbols 									
IP	<p>IPv4:</p> <ul style="list-style-type: none"> • 4 groups of numbers // 12 numbers • separated by full stops (.) • 0-255 in each group • 4 bytes long // 32 bits • Represented in denary <p>IPv6:</p> <ul style="list-style-type: none"> • 8 groups of numbers // 32 numbers • separated by colons (:) • 0-FFFF in each group • 16 bytes long // 128 bits • Consecutive groups of 0000 can be replaced with :: • Represented in hexadecimal 									
MAC	<ul style="list-style-type: none"> • First part is manufacturer ID • Second part is serial number • Each part has 3 pairs of numbers // Each part has 6 numbers // 6 pairs of 2-digits // consists of 12 numbers • ...between 00 and FF • ..separated by : • Each part is 3 bytes // Is 6 bytes long // Is 48 bits long • Represented using hexadecimal 									

Question	Answer	Marks												
5(c)	<p>1 mark for threat. 1 for impact. 1 for software.</p> <p>Do not award identical impacts twice but read whole answer and award if additional impact given. Allow the same software twice. e.g.</p> <table border="1"> <thead> <tr> <th>Threat</th> <th>Impact on company</th> <th>Software</th> </tr> </thead> <tbody> <tr> <td>Denial of service</td> <td> <ul style="list-style-type: none"> Users cannot access the website Loss of sales (of holidays) Loss of reputation </td> <td>Proxy/firewall</td> </tr> <tr> <td>Virus/malware</td> <td> <ul style="list-style-type: none"> Data on the server may be deleted/changed Website may be deleted/changed Server may be filled with data and crash </td> <td>Anti-virus</td> </tr> <tr> <td>Unauthorised access // hacker</td> <td> <ul style="list-style-type: none"> Data could be deleted/stolen/changed </td> <td>Proxy/Firewall</td> </tr> </tbody> </table>	Threat	Impact on company	Software	Denial of service	<ul style="list-style-type: none"> Users cannot access the website Loss of sales (of holidays) Loss of reputation 	Proxy/firewall	Virus/malware	<ul style="list-style-type: none"> Data on the server may be deleted/changed Website may be deleted/changed Server may be filled with data and crash 	Anti-virus	Unauthorised access // hacker	<ul style="list-style-type: none"> Data could be deleted/stolen/changed 	Proxy/Firewall	6
Threat	Impact on company	Software												
Denial of service	<ul style="list-style-type: none"> Users cannot access the website Loss of sales (of holidays) Loss of reputation 	Proxy/firewall												
Virus/malware	<ul style="list-style-type: none"> Data on the server may be deleted/changed Website may be deleted/changed Server may be filled with data and crash 	Anti-virus												
Unauthorised access // hacker	<ul style="list-style-type: none"> Data could be deleted/stolen/changed 	Proxy/Firewall												

Question	Answer	Marks
6	<p>Any seven from:</p> <ul style="list-style-type: none"> (Motion) sensor sends signals to microprocessor analogue signal is converted to digital microprocessor compares signal to stored valueif it does not meet / meets the stored value (and if camera is not recording) the microprocessor sends signal (to camera) to start recording ... if it does not meet / meets the stored value the microprocessor starts/resets the timer When the timer reaches 2 minutes the microprocessor sends signal (to camera) to stop recording Whole process is repeated continually/until turned off 	7

Question	Answer	Marks
7(a)(i)	<p>1 mark for when e.g.</p> <ul style="list-style-type: none"> • Development // when writing the program // when debugging <p>1 mark for explanation to max 2 from: e.g.</p> <ul style="list-style-type: none"> • ... easier to debug • ...stops when an error is detected • ...reports one error at a time • ...can correct errors in run-time // correct the line and then continue running from that point • ...can test one section without the rest of the code being completed 	3
7(a)(ii)	<p>1 mark for when e.g.</p> <ul style="list-style-type: none"> • After completion // For distribution // For final/repeated testing <p>1 mark each to max 2 from: e.g.</p> <p>After completion</p> <ul style="list-style-type: none"> • It creates an executable file • ...than can be distributed without source code • ...so that other people cannot edit/view the code • ...so end users do not need translator software // so end users do not need to compile/interpret each time • ...so it is machine/platform independent (usually) <p>In final testing</p> <ul style="list-style-type: none"> • It creates an executable file • ...do not need to retranslate for each test sequence • ...can test repeatedly with different data faster 	3

Question	Answer	Marks
7(b)	<p>Any four from, max 2 from each:</p> <p>Freeware:</p> <ul style="list-style-type: none">• There is no cost to the user // free trial• No source code provided• ...cannot be modified• Can be redistributed (in same state)• Is subject to copyright <p>Free software:</p> <ul style="list-style-type: none">• User has access to the source code• Can be modified (without restriction)• Can be redistributed (without restriction)• Can have a cost associated but does not have to• Is subject to copyright	4