



UNIVERSITY OF CAMBRIDGE INTERNATIONAL EXAMINATIONS
International General Certificate of Secondary Education

CANDIDATE NAME

CENTRE NUMBER

CANDIDATE NUMBER

* 9 7 6 3 7 9 4 3 8 6 *

DESIGN AND TECHNOLOGY

0445/32

Paper 3 Resistant Materials

October/November 2011

1 hour

Candidates answer on the Question Paper.

No Additional Materials are required.

To be taken together with Paper 1 in one session of 2 hours 15 minutes.

READ THESE INSTRUCTIONS FIRST

Write your Centre number, candidate number and name on all the work you hand in.
Write in blue or black pen.
You may use a soft pencil for any diagrams, graphs or rough working.
Do not use staples, paper clips, highlighters, glue or correction fluid.
DO NOT WRITE IN ANY BARCODES.

Section A

Answer **all** questions in this section.

Section B

Answer **one** question in this section.

You may use a calculator.

The total of the marks for this paper is 50.

The number of marks is given in brackets [] at the end of each question or part question.

For Examiner's Use	
Section A	
Section B	
Total	

This document consists of 15 printed pages and 1 blank page.

Section A

Answer **all** questions in this section.

1 Fig. 1 shows timber being seasoned.

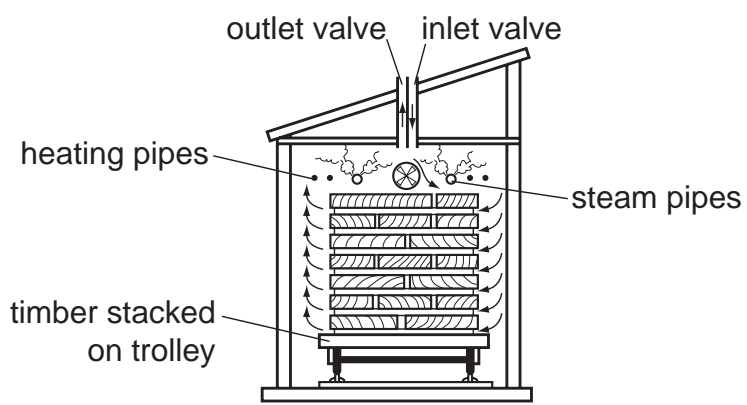

Fig. 1

(a) State the purpose of seasoning timber.

..... [1]

(b) Name the type of seasoning being carried out in Fig. 1.

..... [1]

2 Complete the drawing below to show a tenon saw.

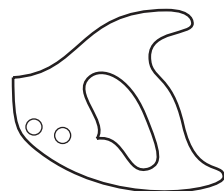

[2]

3 Fig. 2 shows a hand file.

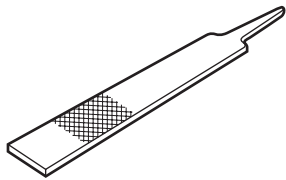

Fig. 2

Label the following parts of the file on Fig. 2:

(a) tang; [1]

(b) safe edge. [1]

4 Give **three** pieces of information needed when buying woodscrews.

1

2 [1]

3 [1]

5 Fig. 3 shows a cross-sectional view of an injection moulding machine.

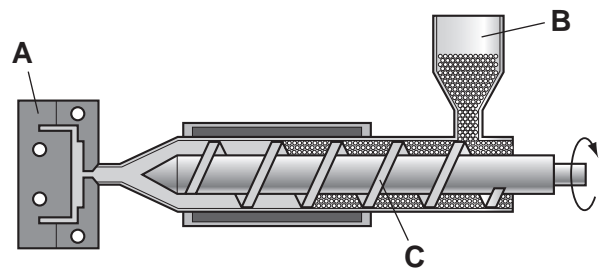

Fig. 3

Name the parts of the injection moulding machine labelled **A**, **B** and **C**.

A [1]

B [1]

C [1]

6 Complete the drawing below to show a finger (comb) joint.

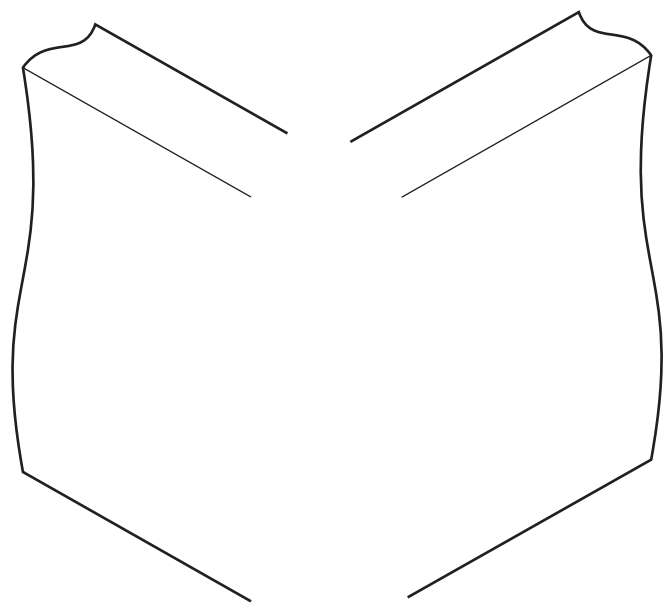

[3]

7 (a) Name the tool shown below.

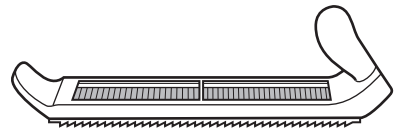

..... [1]

(b) Give **one** specific use for the tool named in part (a).

..... [1]

8 Fig. 4 shows a saucepan.

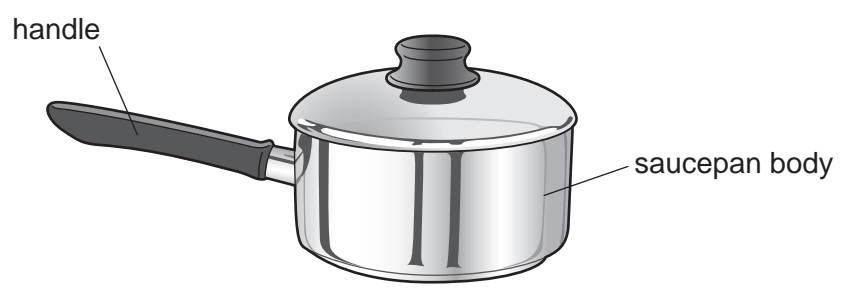

Fig. 4

(a) Name a specific material for the handle and give a reason for your choice.

Specific material [1]

Reason [1]

(b) Name a specific material for the saucepan body and give a reason for your choice.

Specific material [1]

Reason [1]

9 Complete the drawing below to show a butt hinge.

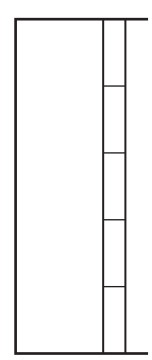

[2]

10 (a) Name the centre lathe operation shown below.

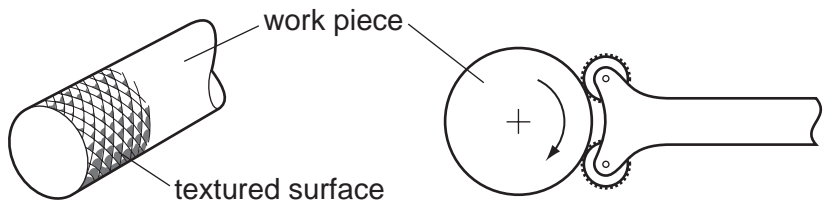

..... [1]

(b) State the purpose of the textured surface produced by the operation shown in part (a).

..... [1]

Section B

Answer **one** question from this section.

- 11 Fig. 5 shows a shape sorting toy to be used by a young child. The sides and shelves of the toy are made from manufactured board and finished with paint. The shapes are made from solid wood and have been left without a finish.

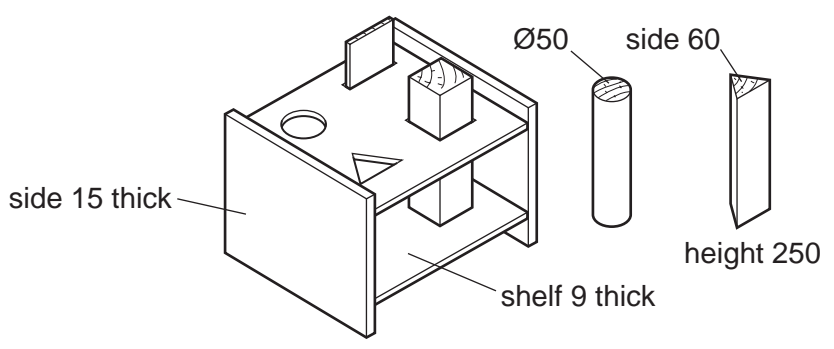

Fig. 5

- (a) State **two** advantages of using manufactured board rather than solid wood for the sides and shelves of the toy.

1 [1]

2 [1]

- (b) Give **two** reasons why the designer has decided to apply a paint finish to the sides and shelves of the toy.

1 [1]

2 [1]

- (c) (i) Draw, in the space below, a suitable joint that could be used to join a shelf to a side of the toy.

(ii) Name the joint you have drawn in part (i).

.....

(iii) Name a suitable adhesive that could be used to make the joint permanent.

..... [1]

(iv) State how long the adhesive would take to dry in normal workshop conditions.

..... [1]

(d) Use sketches and notes to show how you would make the triangular hole.

Include the names of the tools used to:

- mark out the triangular hole;
- cut out the triangular hole;
- make the cut edges of the triangular hole smooth.

[6]

(e) The round shape will be produced from square section, 60 × 60, using a wood turning lathe.

Use detailed sketches and notes to show how you would use a wood turning lathe to produce the round shape.

[6]

8

(f) Fig. 6 shows the triangular shape marked out on a length of solid wood.

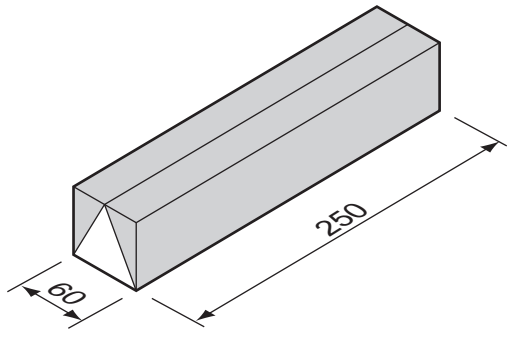

Fig. 6

Use sketches and notes to show how you would produce the triangular shape.

[3]

12 Fig. 7 shows details of a wall-mounted leaflet holder made from acrylic.

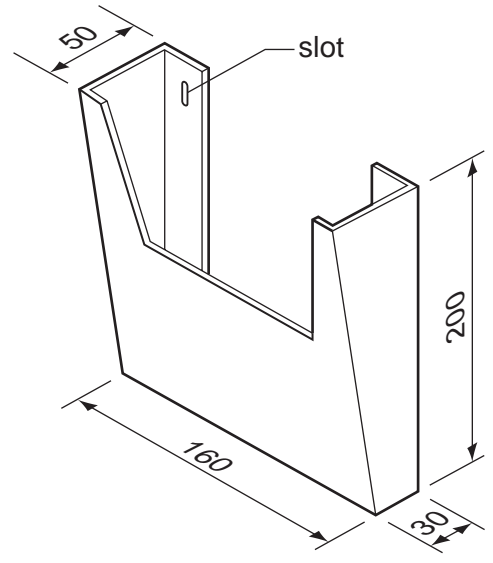

Fig. 7

(a) (i) State **two** items of research a designer would need to consider when designing the leaflet holder.

1 [1]

2 [1]

(ii) Give **two** reasons why a designer would make a model of the leaflet holder before making it from acrylic.

1 [1]

2 [1]

(b) (i) Complete the drawing below to show the development (net) of the leaflet holder.

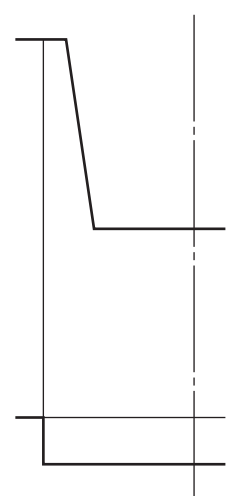

(ii) Name **two** marking out tools used to mark lines on the surface of the acrylic.

1

2 [1]

(c) Fig. 8 shows the front of the leaflet holder marked out, ready to be cut to shape. Use sketches and notes to show how the shape could be cut out and the cut edges made smooth. Name all the tools involved.

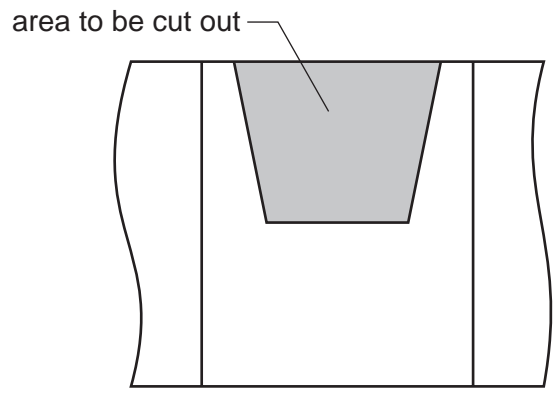
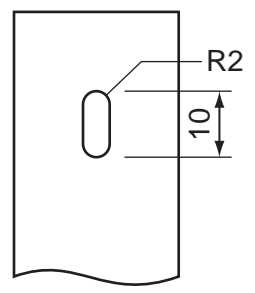

Fig. 8

(d) Use sketches and notes to show how one of the slots in the back of the leaflet could be produced. Include details of marking out.

details of slot



[3]

(e) Use sketches and notes to show how the development (net) of the leaflet holder could be bent to shape.

[6]

13 Fig. 9 shows views of an adjustable magnifying glass and tray used when working with small components such as model kit parts.

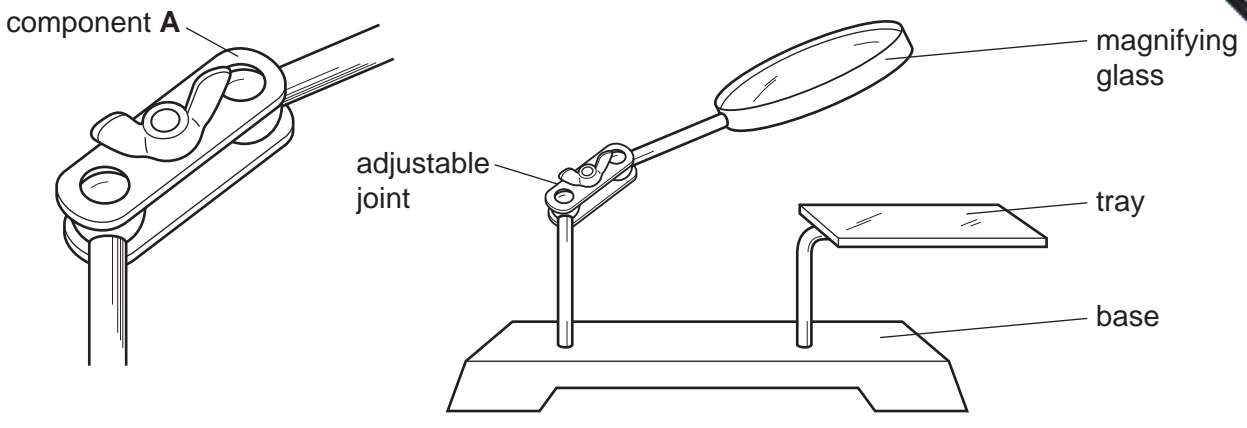

Fig. 9

(a) State why:

(i) the magnifying glass needs to be adjustable;
 [1]

(ii) the base needs to be heavy;
 [1]

(iii) the tray needs to be horizontal.
 [1]

(b) (i) Name the type of nut used to tighten the adjustable joint shown in Fig. 9.
 [1]

(ii) Give **one** benefit of using the type of nut named in part (i).
 [1]

(c) Fig. 10 shows component A and the mild steel blank from which it will be made.

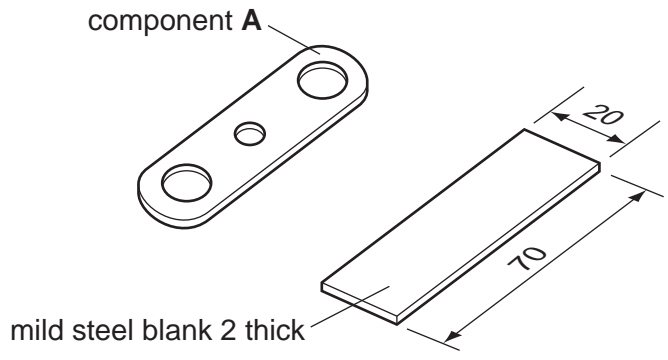

Fig. 10

(i) Use sketches and notes to show how component A could be made from the mild steel blank.
 Include details of marking out and name all the tools and equipment used.

[6]

(ii) Describe how you would make sure that two of component A were made identical.

.....

.....

..... [2]

(d) Fig. 11 shows an exploded view of the tray and its support.

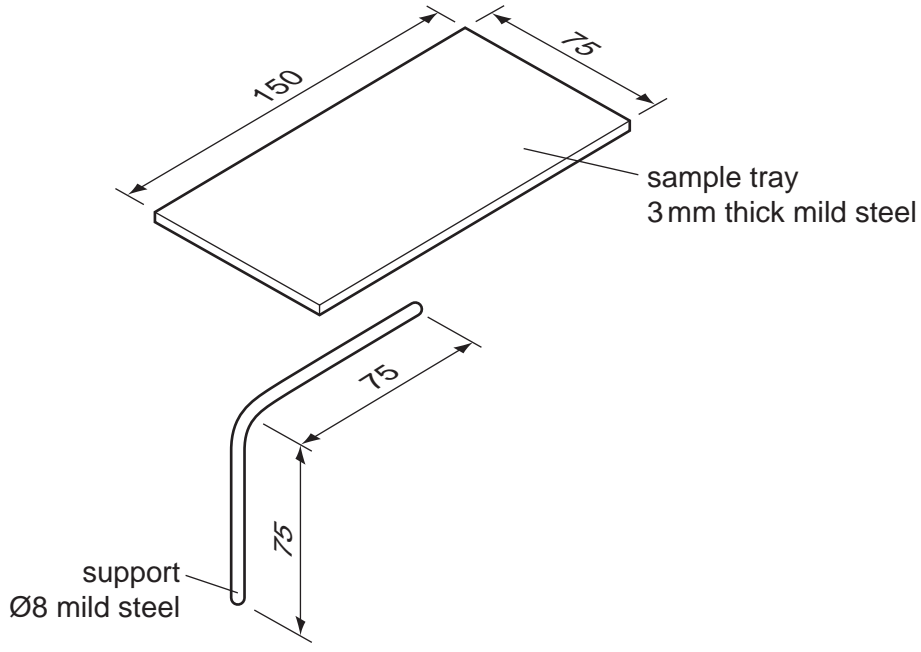

Fig. 11

Use sketches and notes to show how the tray could be joined permanently to the support.
Name all the tools and equipment you would use.

- (e) Use sketches and notes to show how the tray could be made adjustable in height and remain horizontal.
The tray must be locked securely at different heights.
Name any materials and fittings used.

For
miner's
e



[6]

Permission to reproduce items where third-party owned material protected by copyright is included has been sought and cleared where possible. Every reasonable effort has been made by the publisher (UCLES) to trace copyright holders, but if any items requiring clearance have unwittingly been included the publisher will be pleased to make amends at the earliest possible opportunity.

University of Cambridge International Examinations is part of the Cambridge Assessment Group. Cambridge Assessment is the brand name of University of