

**Section A**

Answer **all** questions in this section.

**A1** The drawings below show two designs for card packages with clear plastic windows. In the spaces provided complete:

- (a) the isometric drawing of design **A**; [5]
- (b) the orthographic views of design **B**. [4]

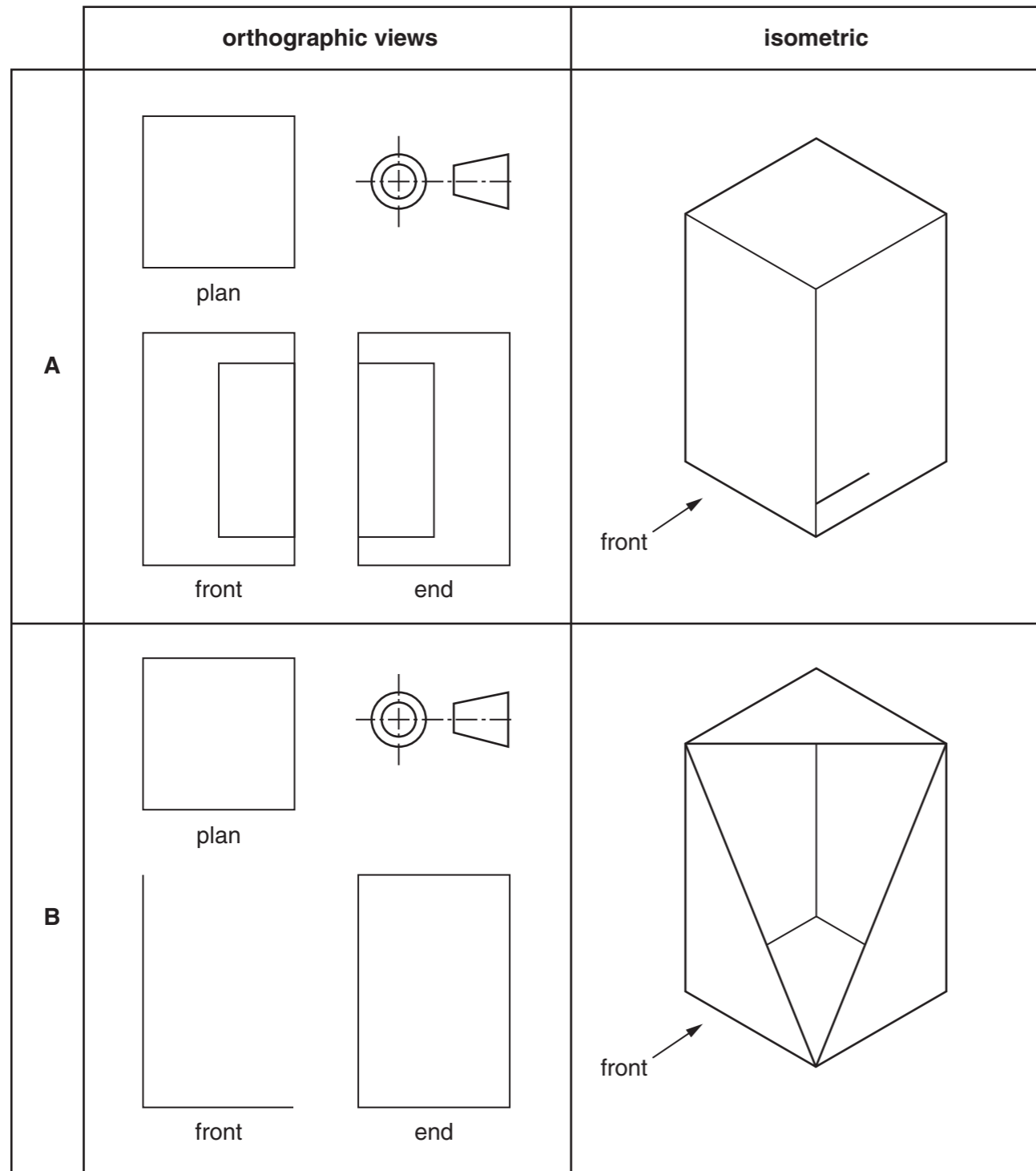

**A2 (a) (i)** Name a plastic that could be used for the windows.

..... [1]

**(ii)** Give two reasons why the material is suitable for this use.

1. .... [1]

..... [1]

2. .... [1]

..... [1]

**(b)** Use a sketch and notes to show a method of fixing a window in place on a card package. [2]

For  
Examiner's  
use

**0445/21** Oct/Nov 2016 **1 hour**  
© UCLES 2016 DC (KN/FD) 136123/5 R

Centre Number ..... Candidate Number ..... Candidate Surname ..... Other Names ..... **[Turn over**

**A3** Design **A** will be used as a package for a metal cup. Orthographic views of the metal cup are shown below.

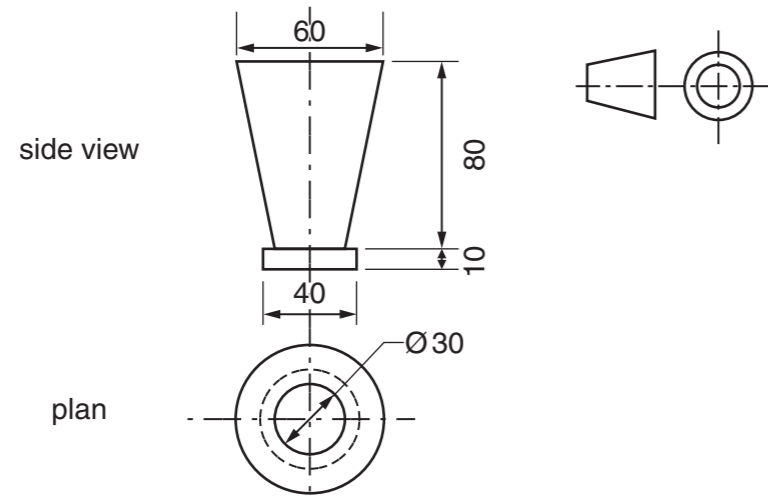

(a) On the centre lines below draw a full-size planometric view of the metal cup. [6]

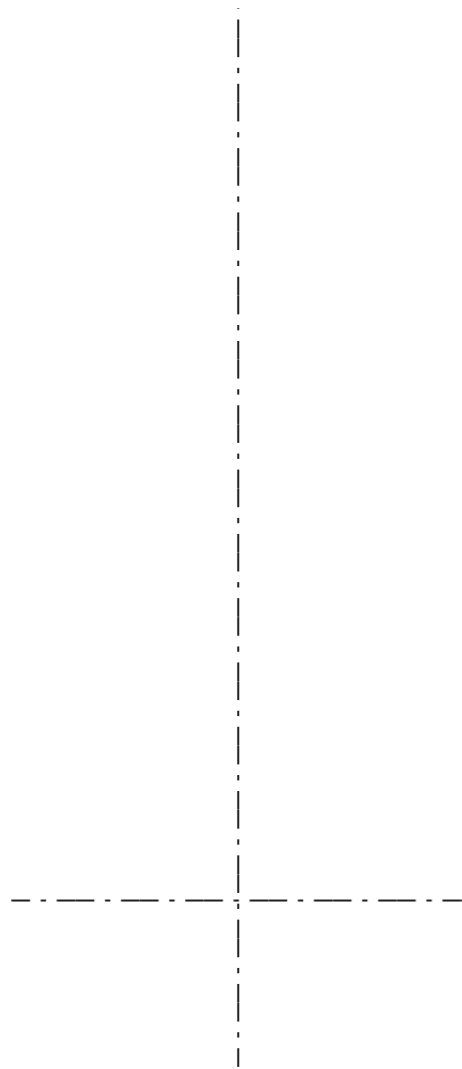

(b) Design **B** is available in three different colours. The sales of each colour in 2015 are shown below.

|       |     |      |        |
|-------|-----|------|--------|
|       | red | blue | yellow |
| sales | 800 | 400  | 600    |

On the centre lines below draw a pie chart to show the sales of each colour. [5]

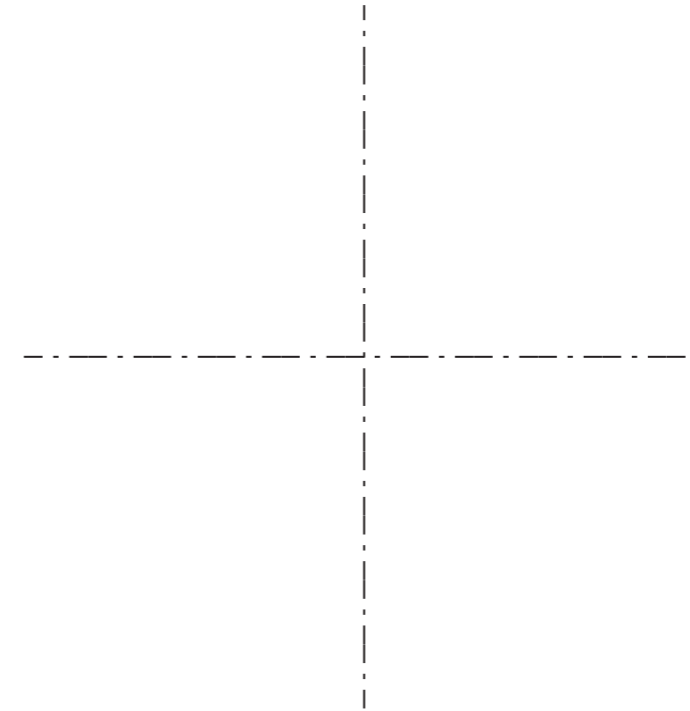

**Section B**  
Answer **either** question **B4** or **B5**.

**B4** Orthographic views of a perfume bottle are shown on the right.

(a) Complete the estimated two-point perspective drawing below of the perfume bottle. [15]

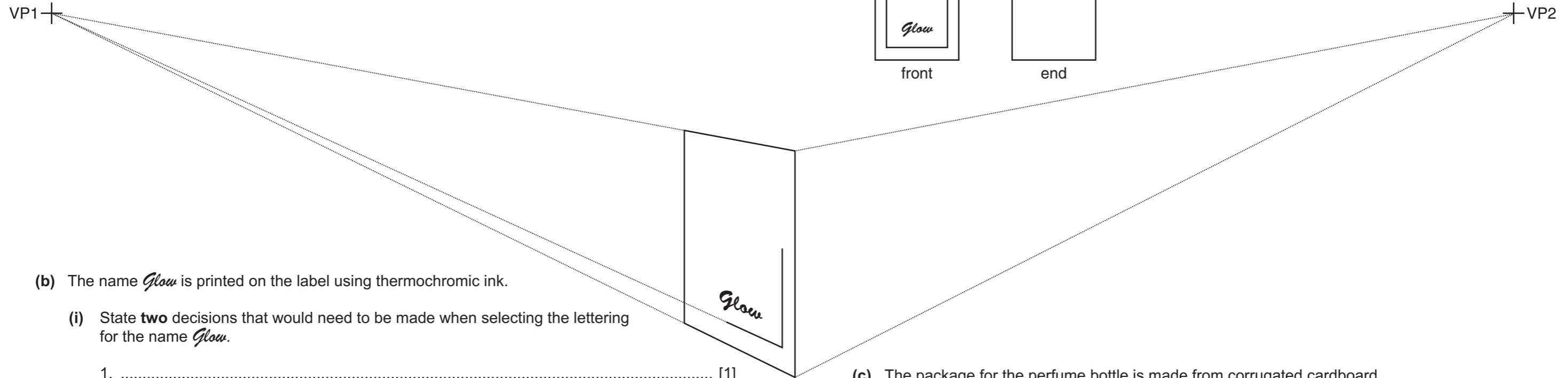
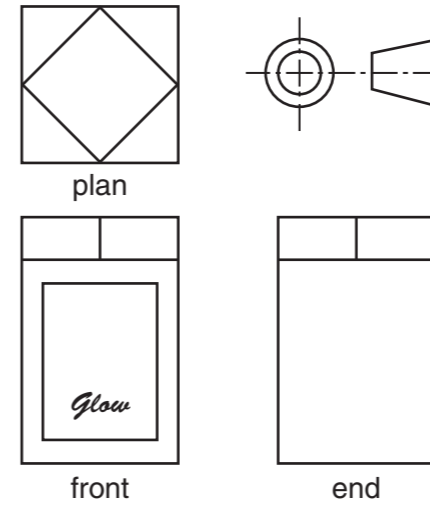

(b) The name *Glow* is printed on the label using thermochromic ink.

(i) State **two** decisions that would need to be made when selecting the lettering for the name *Glow*.

1. .... [1]

2. .... [1]

(ii) In the space below use a sketch and notes to explain how thermochromic ink would add interest to the label. [3]

(c) The package for the perfume bottle is made from corrugated cardboard.

(i) Draw in the space below a sectional view of corrugated cardboard. [3]

(ii) State **two** properties of corrugated cardboard that make it suitable as packaging for the perfume bottle.

1. .... [1]

2. .... [1]

For  
Examiner's  
use

**B5** A sketch of a sports company logo is shown below.

**(a)** Complete the enlargement of the logo. [12]

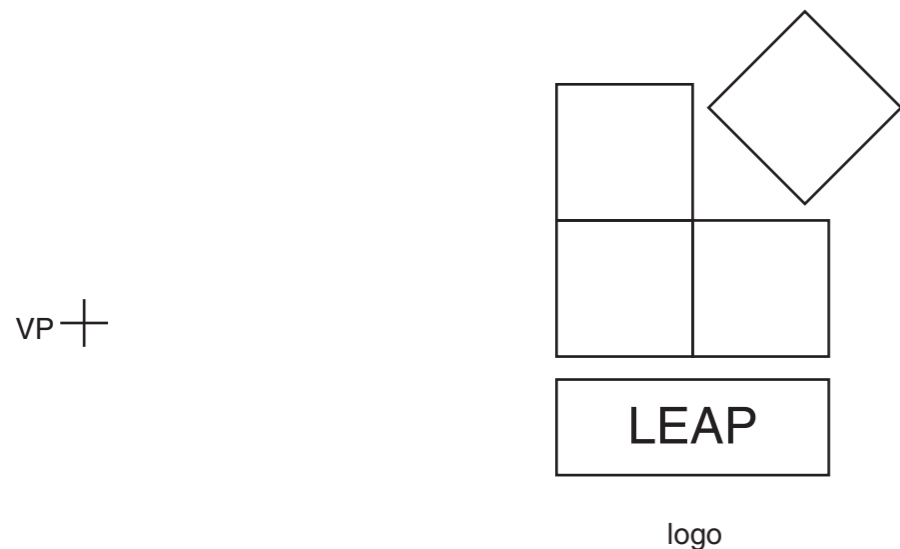

**(c)** A three-dimensional version of the sports logo is shown below. Apply thick and thin line technique to enhance the drawing of the logo below. [3]

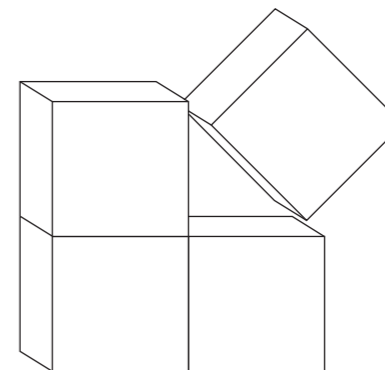

**(b)** The logo is to be screen-printed on a tee-shirt. Use sketches and notes to describe the process of screen printing. [7]

**(d)** Objects are frequently drawn to scale. Complete the table below to show scales that are commonly used in drawing. [3]

| scale | object | drawing |
|-------|--------|---------|
| 1:1   | .....  | 100 mm  |
| 1:2   | 300 mm | .....   |
| 5:1   | 100 mm | .....   |