



Cambridge International Examinations
Cambridge International General Certificate of Secondary Education

CANDIDATE
NAME

CENTRE
NUMBER

--	--	--	--	--

CANDIDATE
NUMBER

--	--	--	--



DESIGN AND TECHNOLOGY

0445/32

Paper 3 Resistant Materials

May/June 2018

1 hour

Candidates answer on the Question Paper.

No Additional Materials are required.

READ THESE INSTRUCTIONS FIRST

Write your Centre number, candidate number and name on all the work you hand in.

Write in dark blue or black pen.

You may use an HB pencil for any diagrams, graphs or rough working.

Do not use staples, paper clips, glue or correction fluid.

DO NOT WRITE IN ANY BARCODES.

Section A

Answer **all** questions in this section.

Section B

Answer **one** question in this section.

You may use a calculator.

At the end of the examination, fasten all your work securely together.

The number of marks is given in brackets [] at the end of each question or part question.

The total of the marks for this paper is 50.

This document consists of **18** printed pages and **2** blank pages.

Section A

Answer **all** questions in this section.

- 1 Fig. 1 shows a door bolt made from steel for use in a bathroom. The bolt has a chrome finish.

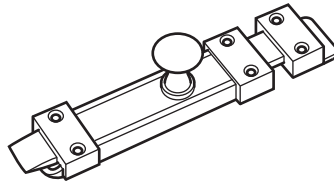

Fig. 1

Give **two** benefits of a chrome finish for the door bolt.

- 1
- 2 [2]

- 2 Fig. 2 shows an incomplete leg fastening used to join a leg to the rails of a table.

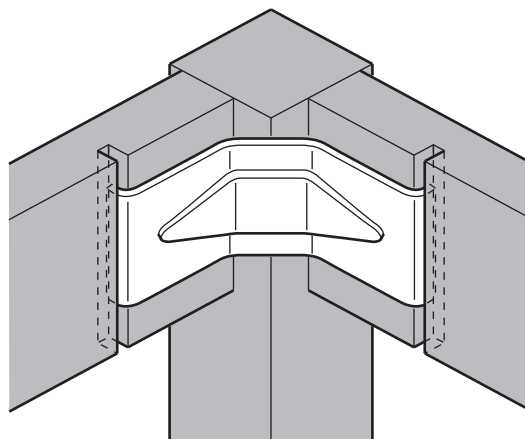
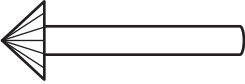



Fig. 2

Add to Fig. 2 to show how the leg fastening could be fixed to the leg and the rails. [3]

3 Complete the table below by adding the correct name from the list.

forstner countersink flat twist centre

Drill	Name
	
	
	

[3]

4 Fig. 3 shows a skateboard. The deck is made by gluing thin layers of wood together.

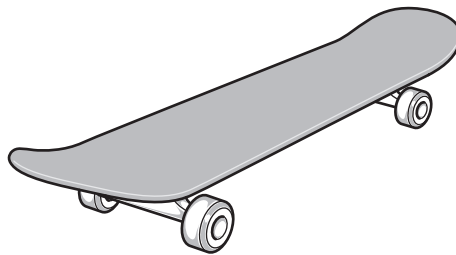

Fig. 3

(a) Give the correct term for ‘thin layers of wood’.

.....[1]

(b) Complete the statement below by adding the correct term from the list.

casting machining shaping laminating

Gluing thin layers of wood together is known as[1]

4

5 Fig. 4 shows a handle made from metal.

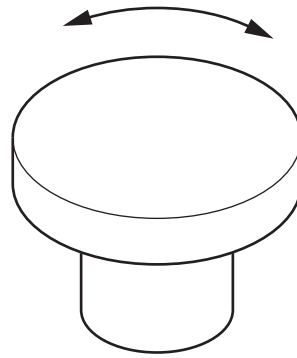

Fig. 4

Add sketches and notes to Fig. 4 to show a modification to the handle that would make it easier to grip and turn. [2]

6 Fig. 5 shows a canoe.

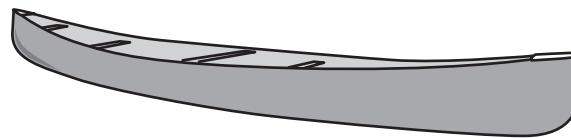

Fig. 5

Name **two** composite materials that could be used to make the canoe.

1

2 [2]

5

7 Fig. 6 shows a piece of steel that has cracked due to work hardening during bending.

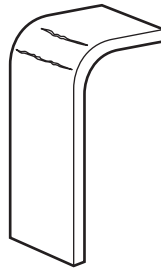

Fig. 6

Explain what is meant by the term 'work hardening'.

.....

.....

..... [2]

8 Fig. 7 shows views of a cabinet and a 6 mm thick sliding glass door to be fitted inside the cabinet. Add sketches and notes to Fig. 7 to show how **two** sliding glass doors could be fitted inside the cabinet.

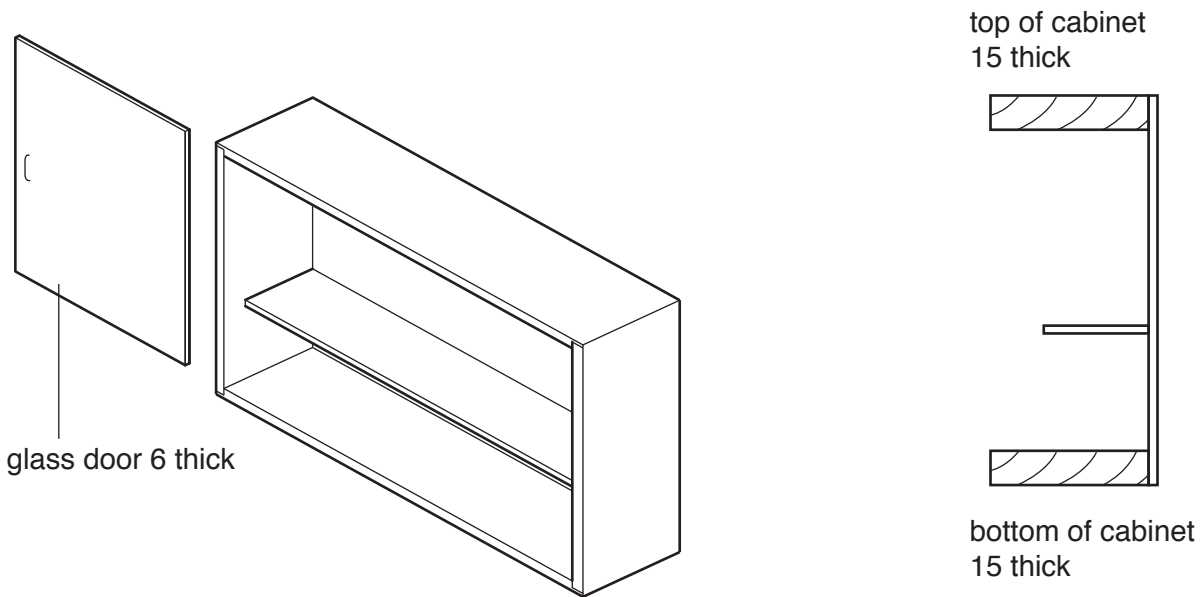

Fig. 7

[3]

- 9 Complete the table by naming the correct plastic from the list below to match each description.

Material	Description of material
nylon	hard, tough, weather resistant, used for pipes, guttering, window frames
melamine	hard-wearing, strong, range of colours, used for decorative laminates
PVC	lightweight plastic, absorbs shock, good heat and sound insulator
polythene	
polystyrene	

[3]

- 10 Fig. 8 shows a person sitting at a desk, using a computer. Three areas, where consideration of ergonomics is required, are labelled **A**, **B** and **C**.



Fig. 8

Describe briefly the ergonomic consideration for **each** of the areas **A**, **B** and **C** shown.

A

B

C [3]

Section B

Answer **one** question from this section.

- 11 Fig. 9 shows a child's desk organiser made from 4 mm thick acrylic. The desk organiser will store paints, brushes, marker pens, crayons and similar equipment.

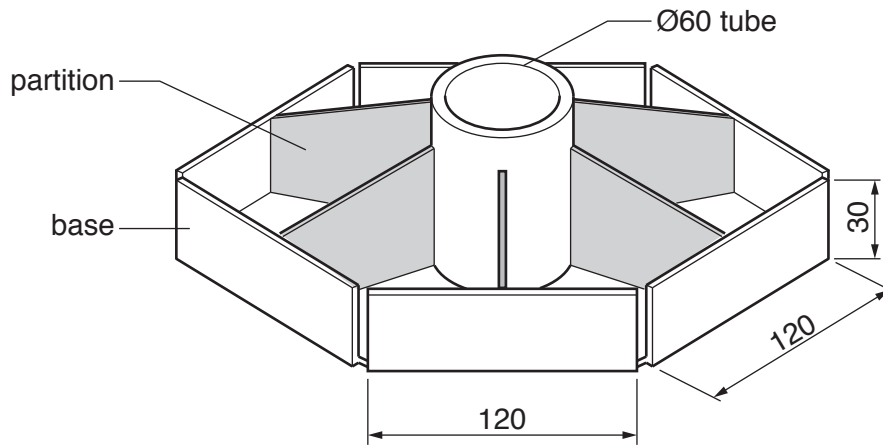

Fig. 9

- (a) Fig. 10 shows the development (net) of the base of the desk organiser as a card template that will be glued to the acrylic.

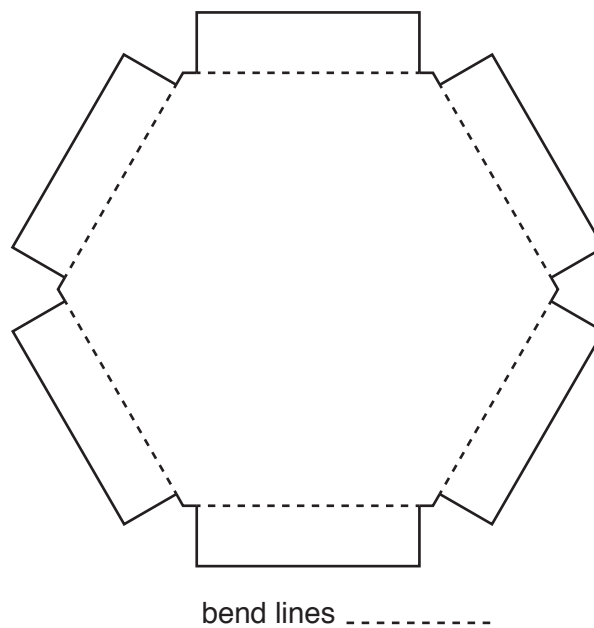

Fig. 10

- (i) Give **one** advantage of using a template rather than marking the development (net) directly onto the acrylic.

.....[1]

(ii) Use sketches and notes to show how the acrylic development (net) could be cut out by hand.

Include the following details:

- the method of holding the acrylic
- the name of a suitable saw
- **one** precaution that would be taken to prevent damage when sawing

[4]

(b) Fig. 11 shows a basic former around which the acrylic will be moulded to shape.

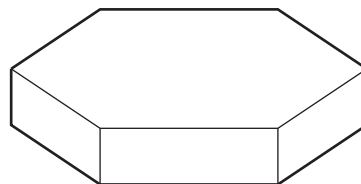

Fig. 11

Describe how the acrylic could be:

- made soft enough to be moulded to shape
- held securely while it cools

[4]

(c) The base of the desk organiser could also be produced by the vacuum forming process.

(i) Name a suitable plastic, other than acrylic, that could be vacuum formed.

.....[1]

(ii) Describe **two** modifications that would need to be made to the former shown in Fig. 11 so that it could be used to vacuum form the base of the desk organiser.

1

2[2]

(iii) Explain why vacuum forming would be a better method of producing the base of the desk organiser if it were to be batch produced.

.....

.....

.....[2]

(d) The partitions will be joined permanently to the base and the Ø60 tube using acrylic cement. Describe **two** safety precautions that must be taken when using acrylic cement.

1

2[2]

(e) Many of the edges of the acrylic will need to be made smooth and highly polished. List **three** tools or items of equipment that could be used to make the edges smooth and highly polished.

1

2

3[3]

- (f) To make it easier for children to access the equipment in the desk organiser an additional base is required that will allow the desk organiser to rotate. Children will then be able to turn the desk organiser to select the equipment they need.

Use sketches and notes to show how the desk organiser could be made to rotate freely on a base.

Include the following details:

- specific materials
- **two** important sizes

[6]

12 Fig. 12 shows a guitar stand made from hardwood. The stand can store up to four guitars.

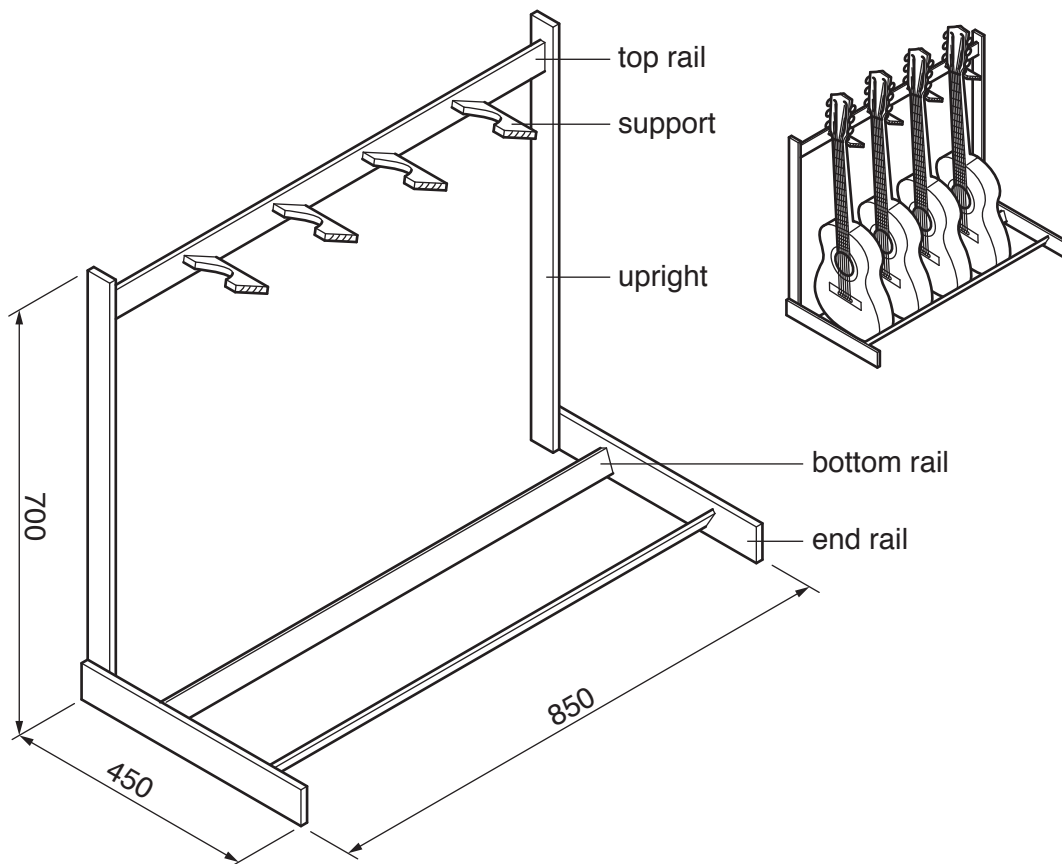

Fig. 12

(a) A parts list for the guitar stand is shown below.

Part	Number reqd.	Length × Width × Thickness	Hardwood
Upright	2	700 × 40 × 15	
Top rail	1	<input type="text"/> × 40 × 15	
Bottom rail	2	<input type="text"/> × 40 × 12	
End rail	2	450 × 60 × 15	
Support	4	120 × 50 × 12	

Complete the parts list by stating the **two** missing dimensions and naming **one** suitable hardwood for the guitar stand. [3]

(b) Give **three** items of research a designer would need to consider when designing the guitar stand.

- 1
- 2
- 3 [3]

(c) Fig. 13 shows one support marked out ready to be cut to shape.

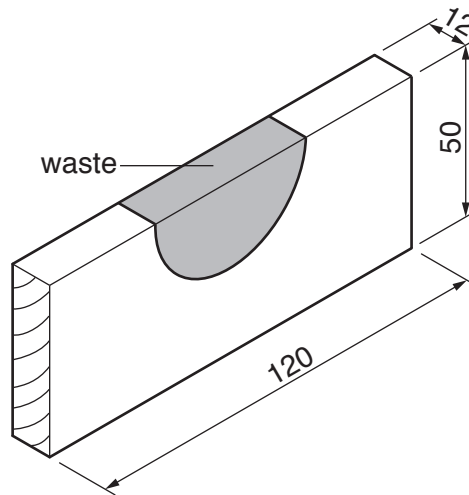

Fig. 13

Complete the table below by naming specific tools or items of equipment used to produce the final shape.

Stage	Process	Specific tool or item of equipment
1	Remove the waste	
2	Produce an accurately shaped curve	
3	Smooth the surfaces	

[3]

(d) Fig. 14 shows views of a bottom rail showing rounded edges.

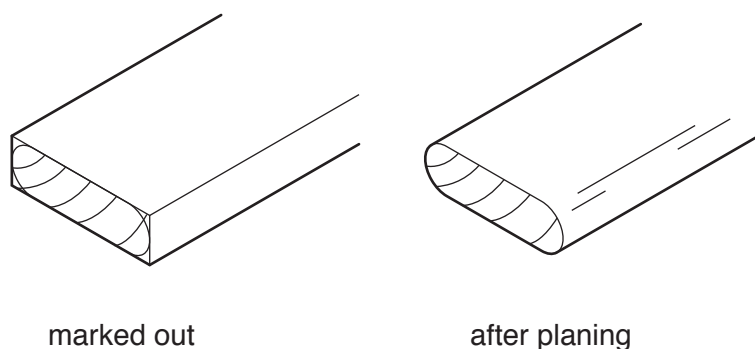

Fig. 14

(i) Name a suitable plane that could be used to produce the rounded edges.

.....[1]

(ii) Give **one** reason why the bottom rails are covered with fabric.

.....[1]

13

(e) The end rails will be joined to the uprights by means of 25 mm long screws. Complete the drawing of the screw shown below by:

- naming the type of head
- showing accurately the length of the screw
- naming a suitable material



not to scale

[3]

(f) Fig. 15 shows one end of the top rail. The top rail is joined to the upright by means of dowels.

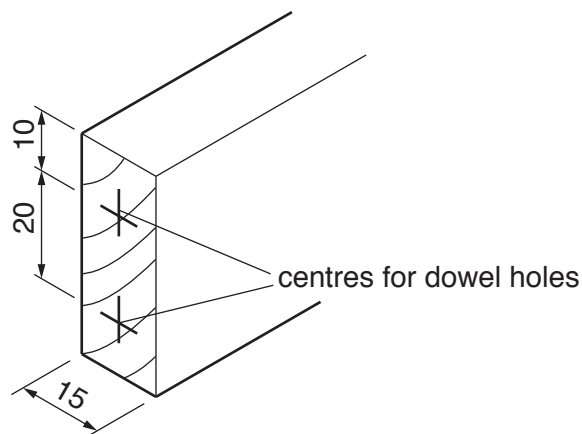

Fig. 15

Use sketches and notes to show a design for a drilling jig that could be used to ensure that holes are drilled accurately in the ends of the top rails.
Name the material/s from which the drilling jig is made.

[5]

- (g) Use sketches and notes to show how a set of 'feet' could be added to the guitar stand.
Name the material used to make the 'feet'.

[3]

- (h) A wax finish will be applied to the guitar stand.

- (i) Give **one** reason why two different grades of abrasive paper would be used to prepare the surfaces before the wax finish is applied.

.....
..... [1]

- (ii) Give **one** reason why the guitar stand would be waxed rather than painted.

.....
..... [1]

- (iii) Give **one** advantage of applying a wax finish rather than a polyurethane varnish finish to the guitar stand.

.....
..... [1]

13 Fig. 16 shows a card model for a safety glasses holder. The holder could be made from wood or metal. The safety glasses holder will be wall-mounted in a school workshop.

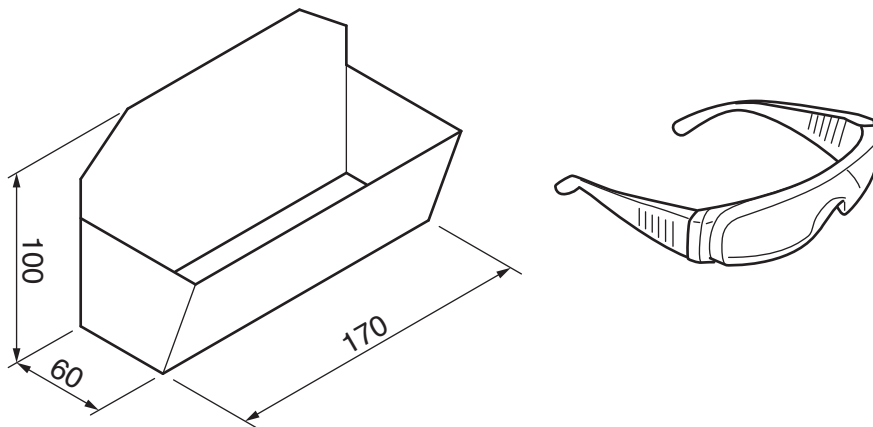

Fig. 16

(a) Give **two** benefits of making a card model of the holder before making it from wood or metal.



- 1
- 2 [2]

(b) The development (net) of the safety glasses holder will be marked out on a sheet of metal.

(i) Name a suitable ferrous metal for the holder.
 [1]

(ii) Name a suitable non-ferrous metal for the holder.
 [1]

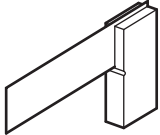
(iii) The table below shows three marking out tools that could be used to mark out sheet metal. Complete the table by giving the specific name for each tool.

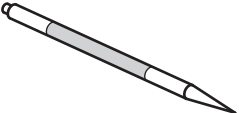
Tool	Name
	
	
	

[3]

- (iv) Explain why tinsnips would be a more effective tool to cut out the shape of the holder rather than a hacksaw.

.....
.....
.....[2]

- (c) Fig. 17 shows a safety glasses holder made from plywood.

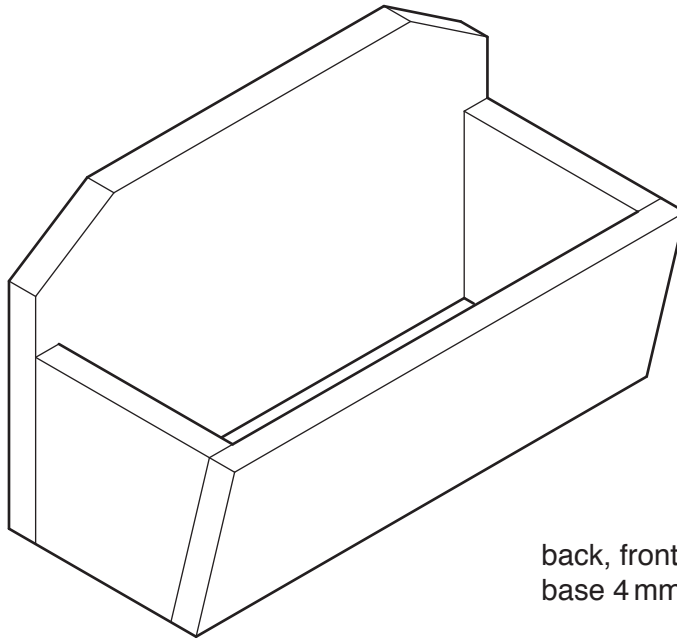

back, front and sides 9 mm thick
base 4 mm thick plywood

Fig. 17

- (i) Plywood is a very stable manufactured board that is unlikely to twist or warp. Use sketches and notes to show the construction of plywood.

[3]

- (ii) Name a different manufactured board that could be used to make the safety glasses holder.

.....[1]

(iii) The parts of the safety glasses holder shown in Fig. 17 will be nailed and glued together. Name a specific type of nail that could be used to join the parts of the holder together.

.....[1]

(iv) State a suitable length for the nail that could be used to join the front to the sides.

.....[1]

(v) Name a suitable adhesive that could be used to glue the parts together.

.....[1]

(vi) State approximately how long the adhesive named in part (v) would take to set.

.....[1]

(d) Choose whether to make the safety glasses holder from metal or plywood.

(i) Use sketches and notes to show a modification to the safety glasses holder so that it could be fixed to a wall and easily removed for cleaning.

[3]

- (ii) Use sketches and notes to show how a 'lid' could be fitted to the holder so that the safety glasses could be kept clean.
Include details of materials and constructions used.

[5]

BLANK PAGE

BLANK PAGE

Permission to reproduce items where third-party owned material protected by copyright is included has been sought and cleared where possible. Every reasonable effort has been made by the publisher (UCLES) to trace copyright holders, but if any items requiring clearance have unwittingly been included, the publisher will be pleased to make amends at the earliest possible opportunity.

To avoid the issue of disclosure of answer-related information to candidates, all copyright acknowledgements are reproduced online in the Cambridge International Examinations Copyright Acknowledgements Booklet. This is produced for each series of examinations and is freely available to download at www.cie.org.uk after the live examination series.

Cambridge International Examinations is part of the Cambridge Assessment Group. Cambridge Assessment is the brand name of University of Cambridge Local Examinations Syndicate (UCLES), which is itself a department of the University of Cambridge.