



# Cambridge IGCSE™

---

**DESIGN & TECHNOLOGY**

**0445/51**

Paper 5 Graphic Products

**October/November 2022**

MARK SCHEME

Maximum Mark: 50

---

**Published**

This mark scheme is published as an aid to teachers and candidates, to indicate the requirements of the examination. It shows the basis on which Examiners were instructed to award marks. It does not indicate the details of the discussions that took place at an Examiners' meeting before marking began, which would have considered the acceptability of alternative answers.

Mark schemes should be read in conjunction with the question paper and the Principal Examiner Report for Teachers.

Cambridge International will not enter into discussions about these mark schemes.

Cambridge International is publishing the mark schemes for the October/November 2022 series for most Cambridge IGCSE™, Cambridge International A and AS Level components and some Cambridge O Level components.

---

This document consists of **6** printed pages.

**Generic Marking Principles**

These general marking principles must be applied by all examiners when marking candidate answers. They should be applied alongside the specific content of the mark scheme or generic level descriptors for a question. Each question paper and mark scheme will also comply with these marking principles.

**GENERIC MARKING PRINCIPLE 1:**

Marks must be awarded in line with:

- the specific content of the mark scheme or the generic level descriptors for the question
- the specific skills defined in the mark scheme or in the generic level descriptors for the question
- the standard of response required by a candidate as exemplified by the standardisation scripts.

**GENERIC MARKING PRINCIPLE 2:**

Marks awarded are always **whole marks** (not half marks, or other fractions).

**GENERIC MARKING PRINCIPLE 3:**

Marks must be awarded **positively**:

- marks are awarded for correct/valid answers, as defined in the mark scheme. However, credit is given for valid answers which go beyond the scope of the syllabus and mark scheme, referring to your Team Leader as appropriate
- marks are awarded when candidates clearly demonstrate what they know and can do
- marks are not deducted for errors
- marks are not deducted for omissions
- answers should only be judged on the quality of spelling, punctuation and grammar when these features are specifically assessed by the question as indicated by the mark scheme. The meaning, however, should be unambiguous.

**GENERIC MARKING PRINCIPLE 4:**

Rules must be applied consistently, e.g. in situations where candidates have not followed instructions or in the application of generic level descriptors.

**GENERIC MARKING PRINCIPLE 5:**

Marks should be awarded using the full range of marks defined in the mark scheme for the question (however; the use of the full mark range may be limited according to the quality of the candidate responses seen).

**GENERIC MARKING PRINCIPLE 6:**

Marks awarded are based solely on the requirements as defined in the mark scheme. Marks should not be awarded with grade thresholds or grade descriptors in mind.

| Question | Answer   | Marks |
|----------|--|-------|
| A1(a)    | Rectangle 20 × 10 [1]<br>In correct position [1]   | 2     |
| A1(b)    | Bottom triangle correct to overlay [1]<br>Middle triangle base on apex of bottom triangle (candidate solution) [1]<br>Middle triangle correct to overlay [1]   | 3     |
| A1(c)    | Base added 50 mm long in correct position [1]<br>Both sides from base to top to candidate solution [1]   | 2     |
| A1(d)    | Leaf 55 mm above base [1]<br>Leaf size correct to overlay [1]  | 2     |
| A1(e)    | Centre circle Ø30 in correct centre position [1]<br>Outer circle R35 in correct centre position [1]<br>6 petals with sides projected from centre of circle [1]<br>3 petals correct to overlay [1]<br>All 6 petals correct to overlay [1] | 5     |
| A1(f)    | Any hexagon [1]<br>Regular hexagon on centre lines [1]<br>Hexagon correct to overlay   | 3     |

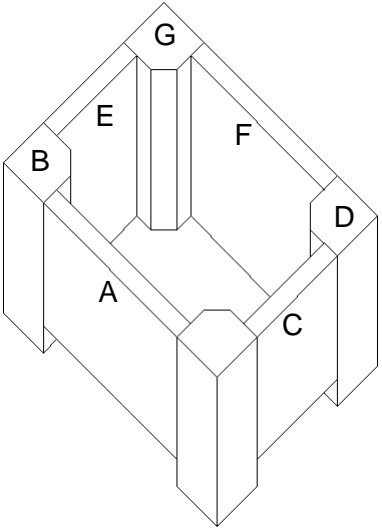
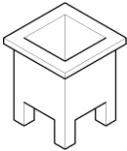

| Question | Answer   | Marks |
|----------|--|-------|
| A2(a)    | Any attempt at ellipse [1]<br>Major axis 140, Minor axis 80 shown [1]<br>Any additional points plotted [1]<br>4 correct points plotted [1]<br>8 or more points plotted correctly [1]<br>Ellipse correct to overlay [1] | 6     |
| A2(b)    | Two sides added from base to edges of ellipse  | 1     |

| Question | Answer                             | Marks |
|----------|------------------------------------|-------|
| A3       | Vacuum forming / blow moulding [1] | 1     |

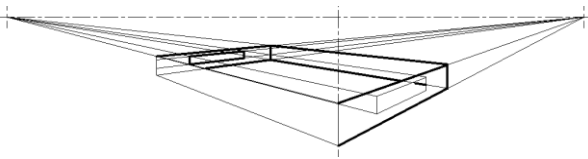
| Question     | Answer   | Marks     |
|--------------|--|-----------|
| <p>B4(a)</p> |  <p>Left side face 'A' and top edge [1]<br/>                 Left side leg top 'B' 30 × 30 [1]<br/>                 Chamfer to top of leg [1]<br/>                 Leg length to overlay [1]</p> <p>Right side face 'C' and top edge [1]<br/>                 Right side leg top 'D' 30 × 30 [1]<br/>                 Chamfer to top of leg [1]<br/>                 Leg length to overlay [1]</p> <p>Left side back inside face 'E' and top edge to candidate solution [1]<br/>                 Right side inside face 'F' and top edge to candidate solution [1]<br/>                 Back corner leg top 'G' 30 × 30 [1]<br/>                 Chamfer to top of leg [1]<br/>                 Leg length to overlay or level with inside faces of E and F [1]<br/>                 4 Internal lines to left and right leg corners [1]</p> | <p>14</p> |
| <p>B4(b)</p> |  <p>Entire outline thick (all centre lines thin) [1]<br/>                 Two bottom lips of top surround thick (top lips thin) [1]<br/>                 Two bottom inside lines thick (both top inside lines thin) [1]<br/>                 Both extended lines on bottom openings (vertical fronts thin) [1]</p>  | <p>4</p>  |

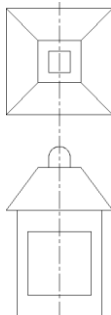
| Question | Answer   | Marks |
|----------|--|-------|
| B4(c)    |  <p data-bbox="311 432 1324 667">           Top and bottom right hand end lines to VP2 [1]<br/>           Top and bottom left hand end line to VP2 [1]<br/>           Vertical back edge of right hand end in proportion (10–15 mm from handle) [1]<br/>           Top and bottom line from right vertical end to VP1 [1]<br/>           Vertical line of inside far back corner correct to candidate solution [1]<br/>           Vertical ends of hand hole projected to opposite end [1]<br/>           Top and bottom lines of hand hole projected to VP2 [1]         </p> | 7     |

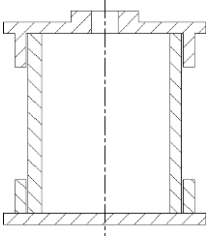
| Question | Answer  | Marks |
|----------|---|-------|
| B5(a)    |  <p data-bbox="311 1160 1149 1261">           Top square on plan to correct size [1]<br/>           Top square on plan in correct position [1]<br/>           Four diagonal lines from inner square to outer square corners [1]         </p> <p data-bbox="311 1294 1013 1395">           Outer width of top projected from plan [1]<br/>           Inner width of top 20 mm wide / projected from plan [1]<br/>           Top height 20 mm [1]         </p> <p data-bbox="311 1429 1236 1597">           Outline of front 50 mm high × 40 mm wide [1]<br/>           Outline of front in correct position on centre line [1]<br/>           Window 40 mm high × 30 mm wide or 5 mm gap at side, 10 mm top and bottom [1]<br/>           Window in correct position on centre line [1]         </p> | 10    |
| B5(b)    | <p data-bbox="311 1630 1005 1697">           Some attempt at diagonal staggered lines added [1]<br/>           High quality communication (looks like clear glass) [1]         </p>   | 2     |

| Question   | Answer   | Marks |
|------------|--|-------|
| B5(c)      |  <p>Cylinder added inside top sleeve [1]<br/>Cylinder height 80 mm [1]<br/>Wall thickness 5 mm [1]</p> <p>Bottom sleeve correct internal widths and position [1]<br/>Bottom sleeve 15 mm high [1]<br/>Base added 90 mm wide and 5 mm thick [1]<br/>Any hatching shown [1]<br/>Hatching added to base, cylinder and sleeve [1]</p> | 8     |
| B5(d)(i)   | <p>Laser cutter can only cut flat sheet materials [1] so cylinder and sleeve parts could not be cut using a laser cutter [1]</p> <p>1 mark for stating laser cutter can only cut sheet material<br/>1 mark for correctly stating parts that can/cannot be cut by laser cutter</p>  | 2     |
| B5(d)(ii)  | <p>Tensol cement or AOVR (e.g. superglue)<br/>Accept tradenames but not generic ones e.g. Gorilla glue</p>   | 1     |
| B5(d)(iii) |  <p>Any skull / crossbones drawing [1]<br/>High quality drawing of skull/crossbones symbol [1]</p>  | 2     |