



Cambridge IGCSE™ (9–1)

CANDIDATE
NAME

CENTRE
NUMBER

--	--	--	--	--

CANDIDATE
NUMBER

--	--	--	--

DESIGN & TECHNOLOGY

0979/32

Paper 3 Resistant Materials

May/June 2022

1 hour

You must answer on the question paper.

No additional materials are needed.

INSTRUCTIONS

- Section A: answer **all** questions.
- Section B: answer **one** question.
- Use a black or dark blue pen. You may use an HB pencil for any diagrams or graphs.
- Write your name, centre number and candidate number in the boxes at the top of the page.
- Answer in the space provided.
- Do **not** use an erasable pen or correction fluid.
- Do **not** write on any bar codes.
- You may use a calculator.

INFORMATION

- The total mark for this paper is 50.
- The number of marks for each question or part question is shown in brackets [].
- All dimensions are in millimetres.

This document has **24** pages. Any blank pages are indicated.



Section A

Answer **all** questions in this section.

- 1 Fig. 1.1 shows a wooden stand for a mobile phone.

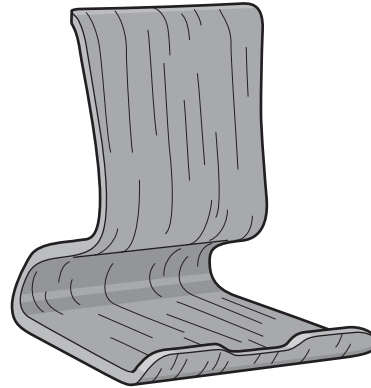

Fig. 1.1

State **two** different processes that could be used to form the shape of the mobile phone stand.

1

2

[2]

- 2 Fig. 2.1 shows two pieces of hardwood prepared to take a countersunk head screw.

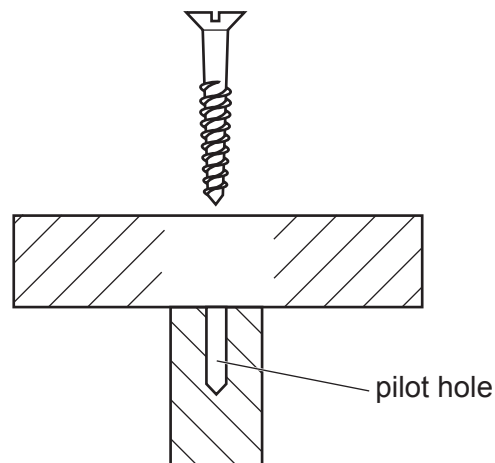

Fig. 2.1

Sketch onto Fig. 2.1 to show:

(a) a countersunk hole

(b) a clearance hole.

[2]

- 3 Products such as chisels and screwdrivers, made from high carbon steel, can be 'hardened'. Hardening makes the metal very brittle. Complete the sentence below by adding the correct term from the list.

normalising tempering annealing alloying

The process of removing the excess 'hardness' and improving the toughness of the steel is known as [1]

- 4 Fig. 4.1 shows a screw thread being cut on a length of mild steel rod using a circular split die held in a die stock.

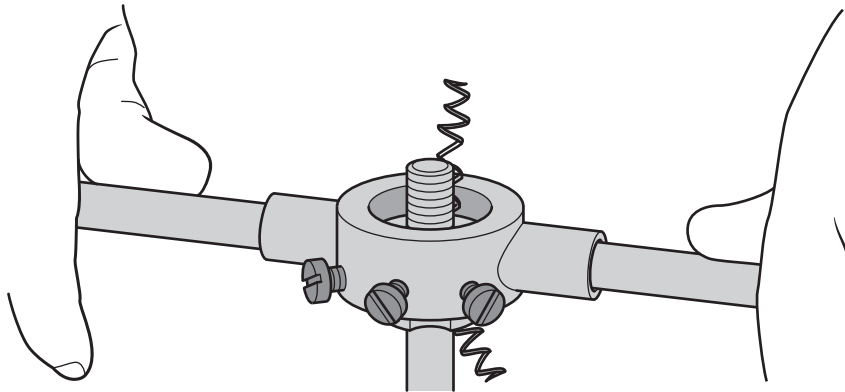
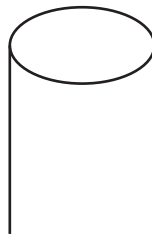

Fig. 4.1

Use sketches and notes to show how the end of the rod shown below could be prepared before the circular split die is used to cut the screw thread.



[2]

5 Complete the sentence below by adding the correct statement from the list.

becomes an antique

takes many years to design

lasts for a fixed period of time

is constructed from the best materials

Planned obsolescence is when a product [1]

6 Fig. 6.1 shows a type of sandwich packaging.

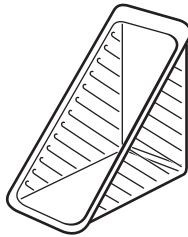

Fig. 6.1

(a) Name a suitable plastic from which the packaging could be made.

..... [1]

(b) Give **one** benefit of using plastic material for food packaging.

..... [1]

(c) Give **one** drawback of using plastic material for food packaging.

..... [1]

7 Fig. 7.1 shows a knock-down (KD) fitting.

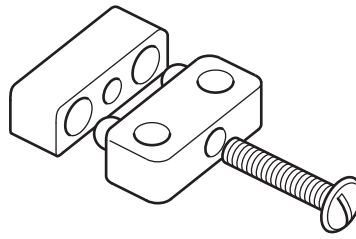

Fig. 7.1

(a) Name the type of knock-down (KD) fitting shown in Fig. 7.1.

..... [1]

(b) Use sketches and notes to show how the knock-down (KD) fitting could be used.

[3]

- 8 Fig. 8.1 shows two camping stools, **A** and **B**.
 Stool **A** is made from oak and stool **B** is made from aluminium tube with a canvas seat.

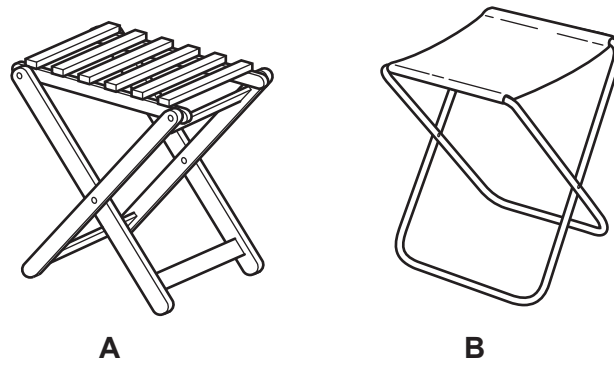

Fig. 8.1

State **three** advantages of stool **B** over stool **A** when in use.

- 1
- 2
- 3

[3]

- 9 Fig. 9.1 shows the end of a length of softwood with a rebate marked out.

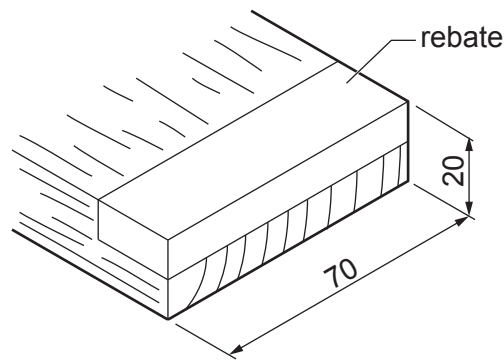

Fig. 9.1

- (a) Name a power tool that could be used to cut out the rebate.

..... [1]

- (b) The rebate could also be cut out using hand tools only.

Complete the names of **two** hand tools that could be used to cut out the rebate.

- 1 saw
- 2 chisel.

[2]

- 10 Fig. 10.1 shows an incomplete design for a trophy made from 1 mm thick brass. The trophy requires a wooden base to make it stable.

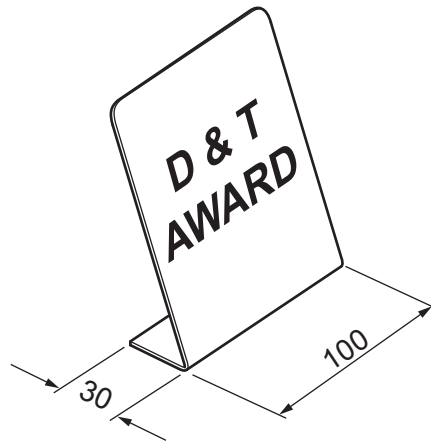

Fig. 10.1

Use sketches and notes to show a design for a wooden base to which the trophy could be attached. Show a suitable method of attachment and give **one** important dimension.

[4]

Section B

Answer **one** question from this section.

- 11 Fig. 11.1 shows views and details of a garden lantern.
The lantern has a plastic candle with a flickering bulb that imitates a real flame.

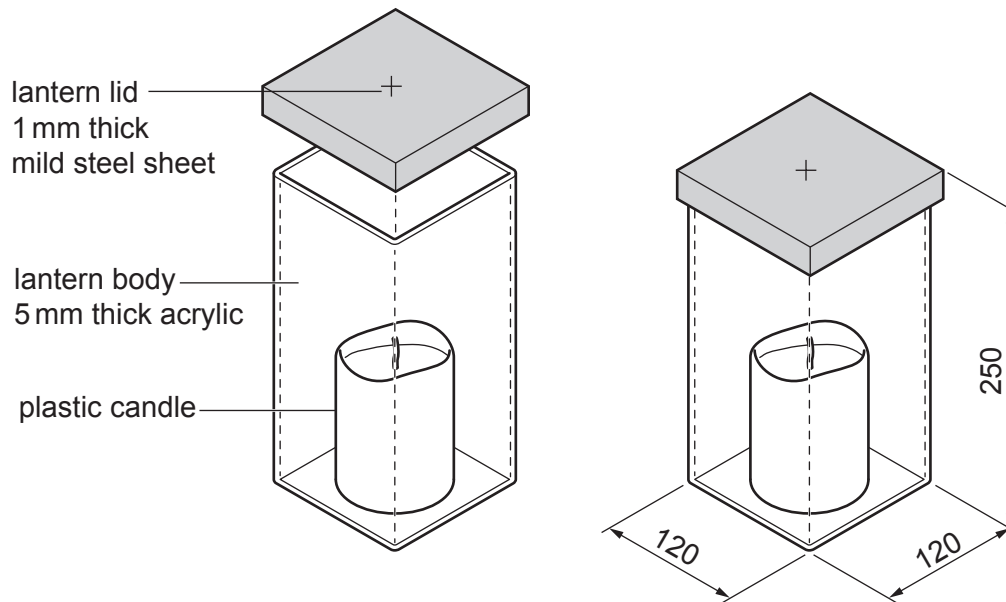

Fig. 11.1

- (a) (i) State **one** property of mild steel sheet that makes it suitable for the lantern lid.

..... [1]

- (ii) The mild steel lantern lid requires a finish.
State **two** suitable finishes that could be applied to the lantern lid.

1

2

[2]

- (b) A card model of the garden lantern will be made before making it from resistant materials.

- (i) State **one** benefit of making a card model of the garden lantern.

..... [1]

- (ii) State **one** benefit of using CAD for on-screen modelling of the garden lantern.

..... [1]

- (c) Fig. 11.2 shows the development (net) of the lantern lid marked out on mild steel sheet. An additional view shows inside the lantern lid when the flaps have been bent and joined permanently to the sides.

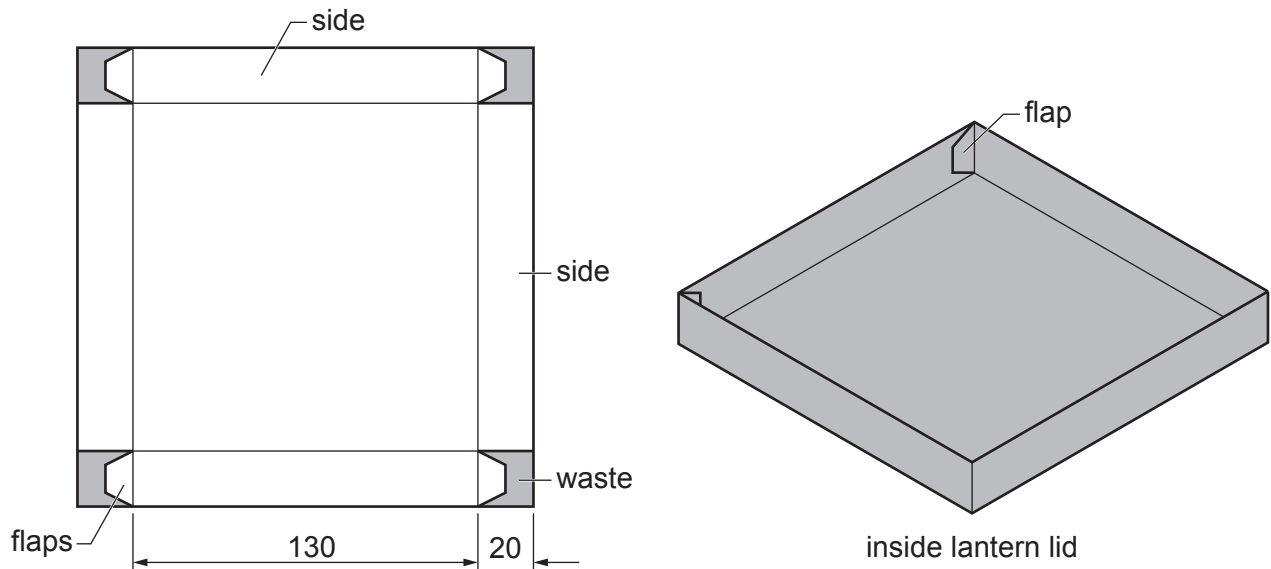

Fig. 11.2

- (i) Name **two** tools or items of equipment that could be used to mark out the development (net) of the lantern lid on the surface of the mild steel sheet.

1

2

[2]

- (ii) Name the tool shown in Fig. 11.3 that could be used to cut out the mild steel sheet.

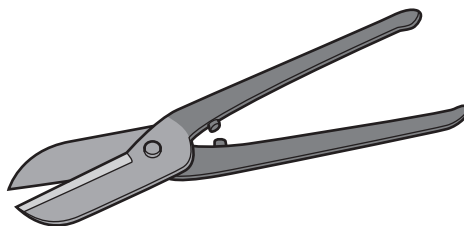

Fig. 11.3

..... [1]

- (iii) Name a permanent method of joining the flaps to the sides that uses heat.

..... [1]

- (iv) Name an adhesive that could be used to join the flaps to the sides of the lantern lid.

..... [1]

10

(d) Fig. 11.4 shows the development (net) of the lantern body made from 5 mm thick acrylic.

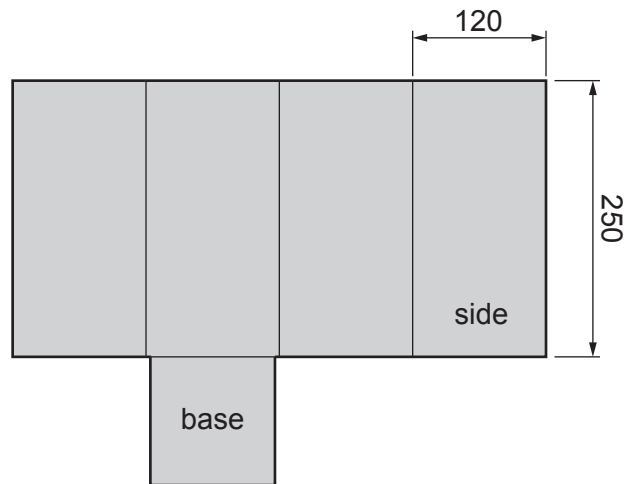

Fig. 11.4

Use sketches and notes to show how the development (net) could be formed to produce the shape of the lantern body.

[5]

(e) Fig. 11.5 shows the garden lantern and part of a support from which it will be suspended.

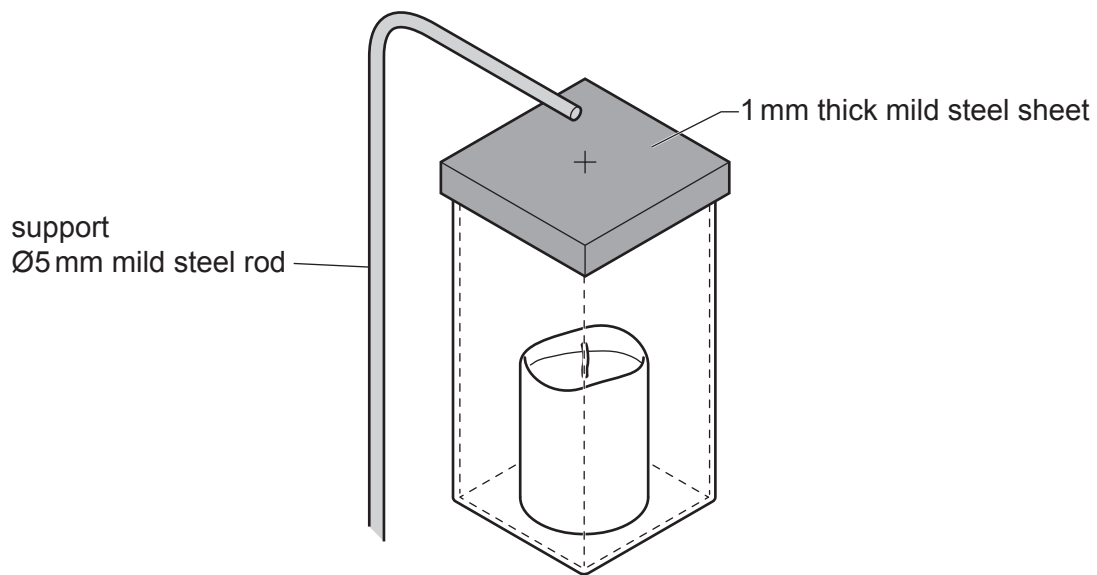

Fig. 11.5

Use sketches and notes to show a method of joining the lantern lid to the lantern body so that it could be easily removed to allow access to the plastic candle. Include details of the fittings and constructions used.

[4]

- (f) Use sketches and notes to show modifications to the lantern lid and the end of the support shown in Fig. 11.5 so that the garden lantern could be suspended safely.

The modifications must allow the garden lantern to be detached from the support. Include details of the materials, fittings and constructions used.

[6]

12 Fig. 12.1 shows an incomplete design for a pinball game.

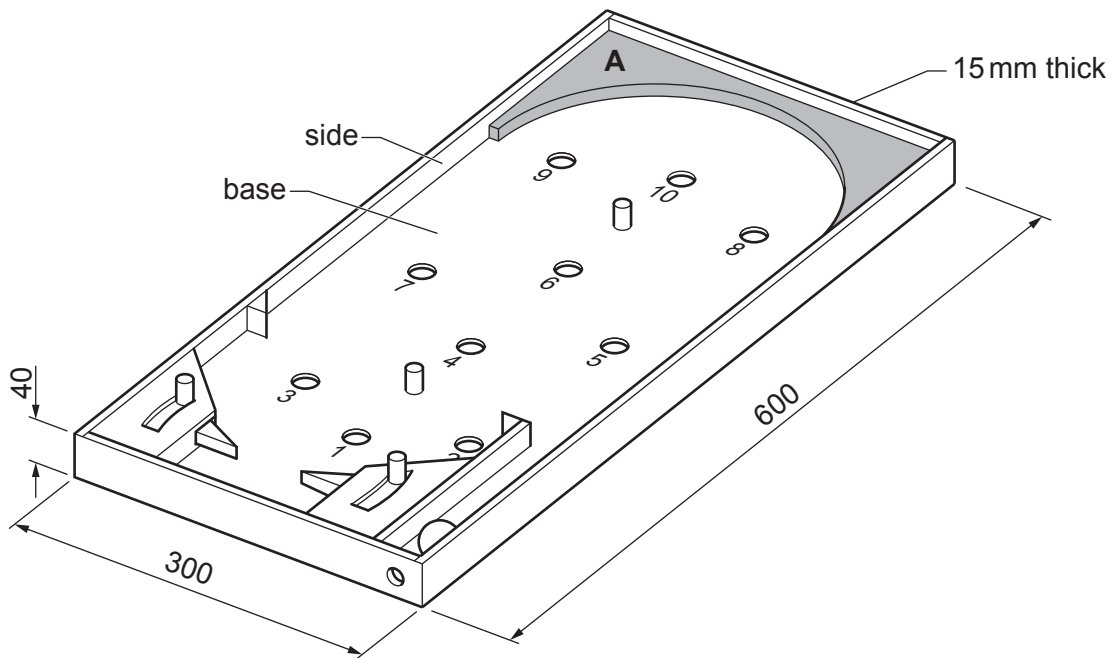

Fig. 12.1

(a) The sides of the pinball game are made from beech.
Give **two** properties of beech that make it suitable for the pinball game.

- 1
- 2 [2]

(b) State **two** ways in which the designer would need to consider safety when designing the pinball game.

- 1
- 2 [2]

(c) Fig. 12.2 shows part of two sides that will be joined at each corner of the pinball game.

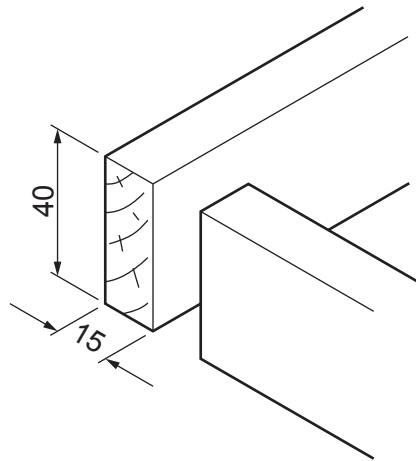

Fig. 12.2

Sketch and name a suitable corner joint that could be used to join the sides of the pinball game together.

Name of construction

[4]

- (d) Fig. 12.3 shows a type of drill bit that could be used to drill the Ø20 holes in the base of the pinball game.

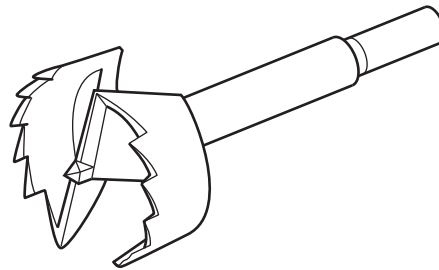

Fig. 12.3

- (i) Name the type of drill bit shown in Fig. 12.3.

..... [1]

- (ii) Give **two** reasons why scrap wood would be clamped underneath the base of the pinball game when drilling the holes.

1

2

[2]

- (e) Fig. 12.4 shows two methods, **A** and **B**, that could be used to fit the base to the sides of the pinball game.

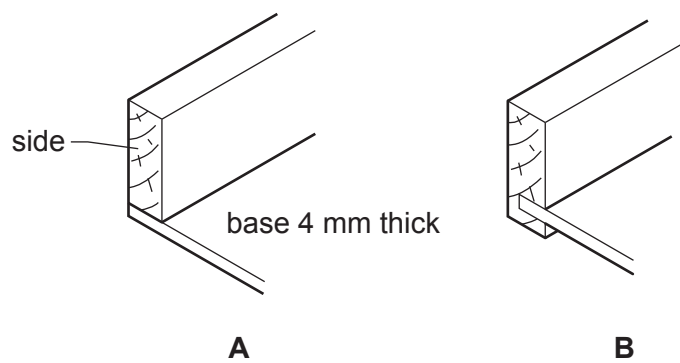

Fig. 12.4

Give **two** advantages of using method **B** rather than method **A**.

1

2

[2]

(f) Fig. 12.5 shows the MDF sheet from which the curved shape will be produced.

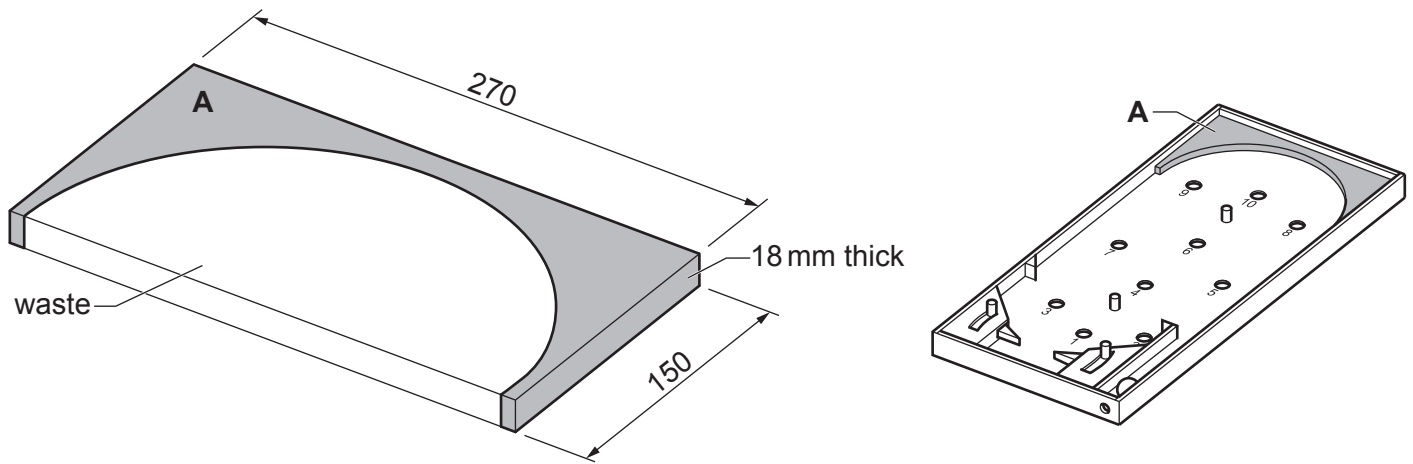

Fig. 12.5

(i) Name **two** different machine tools that could be used to cut out the curved shape.

1

2

[2]

(ii) The finished shape could be glued onto the base of the pinball game using either PVA or a contact adhesive.

State **one** benefit of using PVA and **one** benefit of using a contact adhesive.

Benefit of PVA

.....

Benefit of contact adhesive

.....

[2]

- (g) To produce the curved shape from a sheet of MDF could be considered wasteful. It would be more cost-effective to use the strip of beech shown below.

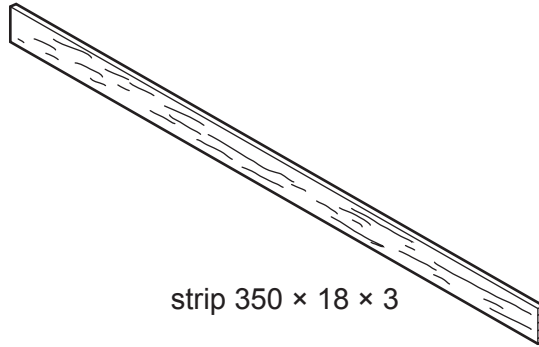

Use sketches and notes to show how the strip of beech could be bent to produce the curved shape and be fitted onto the base of the pinball game.

[4]

(h) The pinball game needs to be supported at an angle to allow the ball to roll down the slope.

Use sketches and notes to show how one end of the pinball game could be supported at the height shown in Fig. 12.6.

The method of support must allow the pinball game to fold flat when not in use.

Include details of the materials and fittings used.

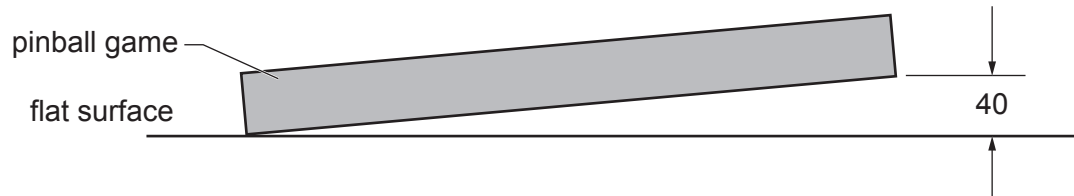

Fig. 12.6

[4]

- 13 Fig. 13.1 shows an incomplete design for a child's toy lorry that could be made in a school workshop. The sides are made from acrylic. The tipper is made from ABS. The base, cab and wheels are made from beech.

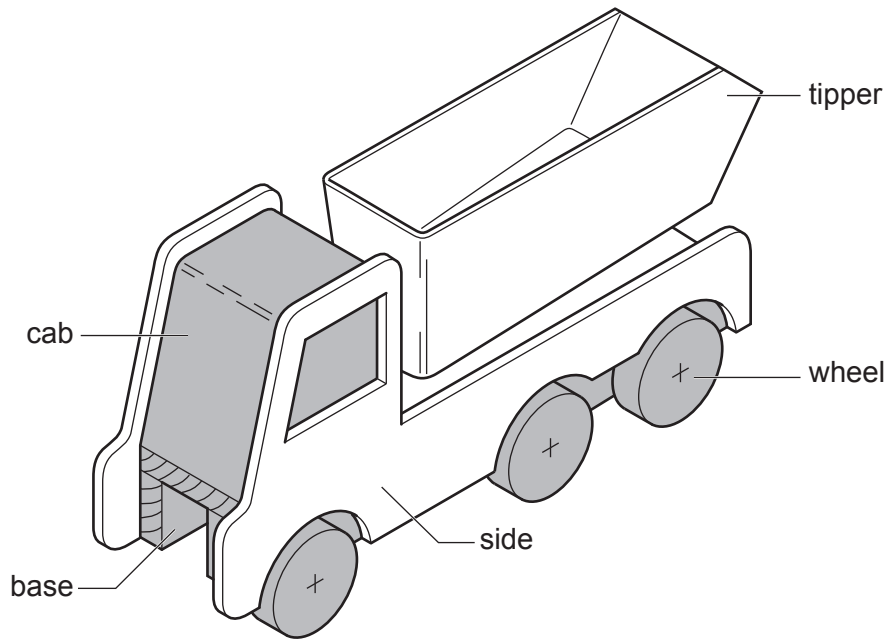

Fig. 13.1

- (a) (i) State **one** benefit of using plastics such as acrylic and ABS for parts of the toy lorry.

..... [1]

- (ii) State **one** benefit of using beech for the base, cab and wheels of the toy lorry.

..... [1]

- (b) The sides of the toy lorry have been designed using CAD.
 Fig. 13.2 shows one side of the toy lorry made from 5 mm thick acrylic.

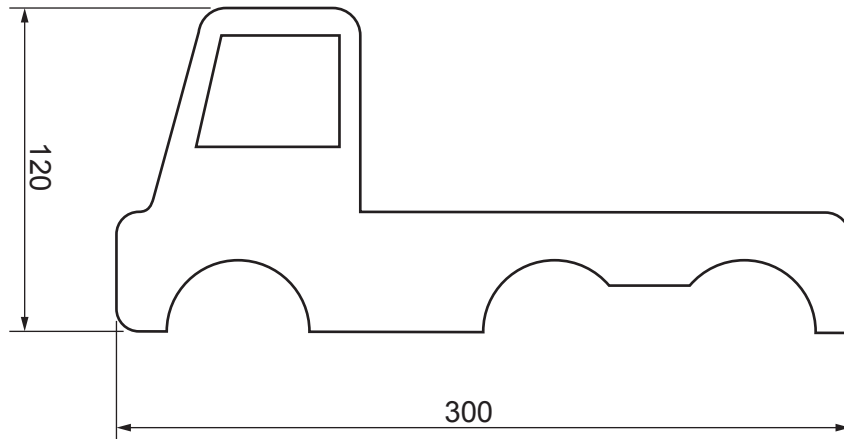

Fig. 13.2

- (i) Complete Table 13.1 by stating **three** processes to be carried out when making the side using CAM.

Table 13.1

Stage	Process
1	<i>Design side of lorry using CAD and save file</i>
2	
3	
4	

[3]

- (ii) The acrylic sides could be glued to the beech base using a contact adhesive. Describe how a contact adhesive would be applied to make a strong joint.

.....

.....

..... [2]

(c) Fig. 13.3 shows details of the tipper that will be vacuum formed using 3 mm thick ABS.

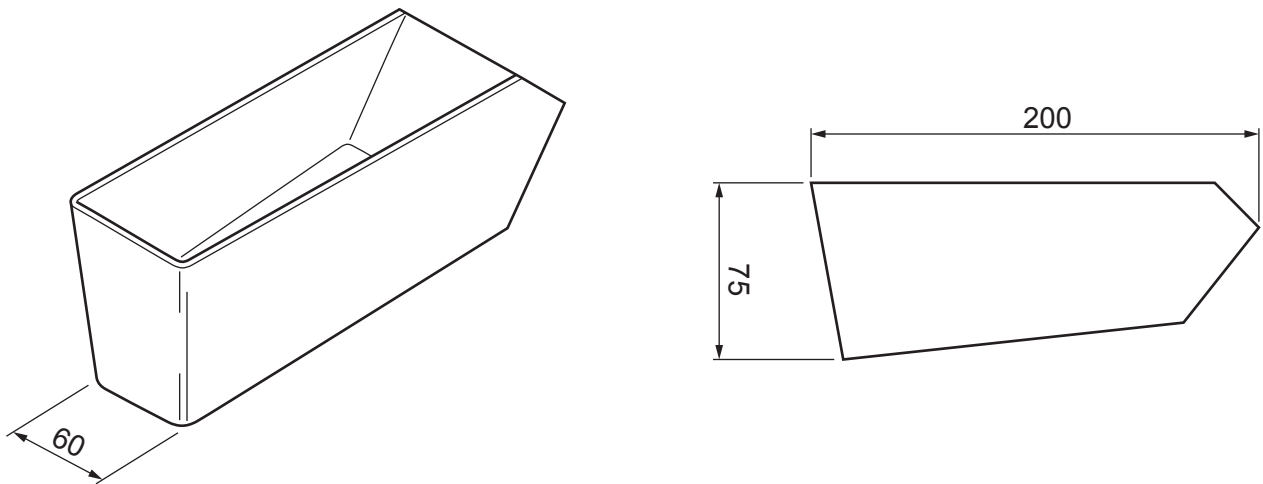

Fig. 13.3

(i) Give **two** advantages of making the vacuum forming mould from MDF rather than a solid wood.

- 1
- 2 [2]

(ii) State **two** features of the vacuum forming mould that are necessary to ensure a successfully formed product.

- 1
- 2 [2]

(iii) Complete Table 13.2 by stating **four** processes to be carried out when vacuum forming the tipper.

Table 13.2

Stage	Process
1	<i>Place mould in vacuum forming machine</i>
2	
3	
4	
5	
6	<i>Remove vacuum formed tipper from machine</i>

[4]

- (d) Fig. 13.4 shows the tipper that will be attached to the base. The tipper will pivot at point A as shown.

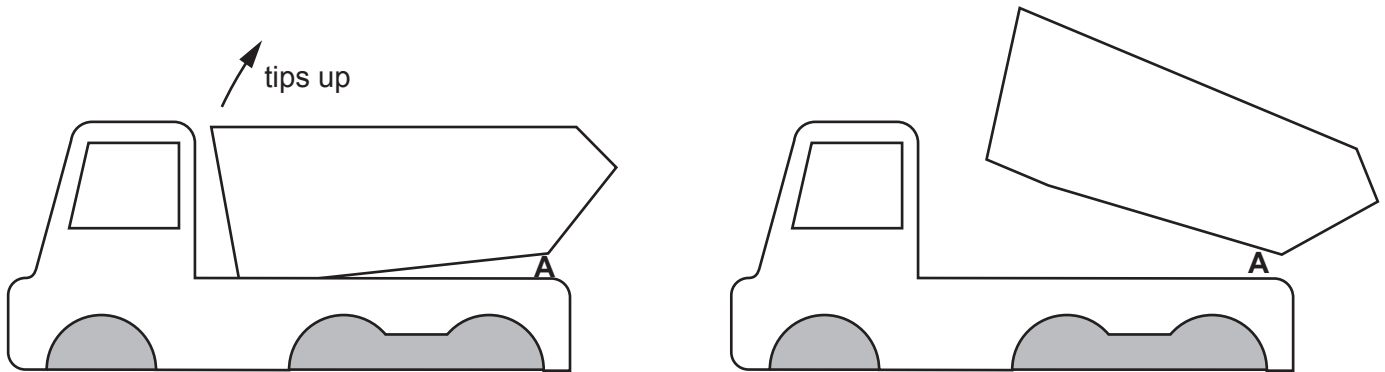

Fig. 13.4

Fig. 13.5 shows details of the base joined to one side.

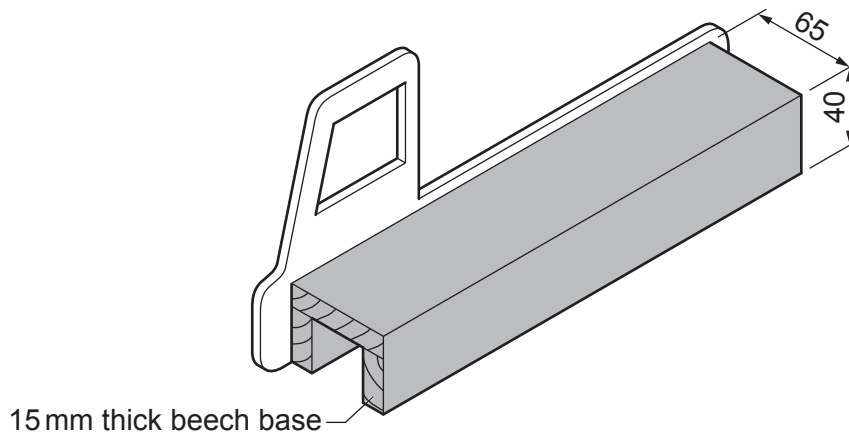

Fig. 13.5

Use sketches and notes to show how the tipper could be made to tip while attached to the base.

Include details of all the constructions, materials and fittings used.

(e) Fig. 13.6 shows details of one of the wheels that will be fixed to the toy lorry.

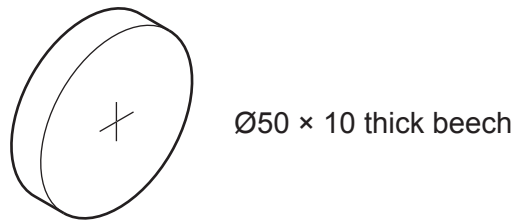

Fig. 13.6

Use sketches and notes to show a method of attaching the wheels to the base that allows them to rotate freely.
Include details of all the constructions, materials and fittings used and state **one** important dimension.

[4]

BLANK PAGE

Permission to reproduce items where third-party owned material protected by copyright is included has been sought and cleared where possible. Every reasonable effort has been made by the publisher (UCLES) to trace copyright holders, but if any items requiring clearance have unwittingly been included, the publisher will be pleased to make amends at the earliest possible opportunity.

To avoid the issue of disclosure of answer-related information to candidates, all copyright acknowledgements are reproduced online in the Cambridge Assessment International Education Copyright Acknowledgements Booklet. This is produced for each series of examinations and is freely available to download at www.cambridgeinternational.org after the live examination series.

Cambridge Assessment International Education is part of Cambridge Assessment. Cambridge Assessment is the brand name of the University of Cambridge Local Examinations Syndicate (UCLES), which is a department of the University of Cambridge.