



UNIVERSITY OF CAMBRIDGE INTERNATIONAL EXAMINATIONS
International General Certificate of Secondary Education
General Certificate of Education Ordinary Level

CANDIDATE
NAME

CENTRE
NUMBER

--	--	--	--	--

CANDIDATE
NUMBER

--	--	--	--



ENVIRONMENTAL MANAGEMENT

**0680/04
5014/02**

Alternative to Coursework

October/November 2008

1 hour 30 minutes

Candidates answer on the Question Paper

Additional Materials: Ruler

READ THESE INSTRUCTIONS FIRST

Write your Centre number, candidate number and name on all the work you hand in.

Write in dark blue or black pen.

You may use a soft pencil for any diagrams, graphs or rough working.

Do not use staples, paper clips, highlighters, glue or correction fluid.

DO NOT WRITE IN ANY BARCODES.

Answer **all** questions.

Study the appropriate Source materials before you start to write your answers.

Credit will be given for appropriate selection and use of data in your answers and for relevant interpretation of these data. Suggestions for data sources are given in some questions.

You may use the source data to draw diagrams and graphs or to do calculations to illustrate your answers.

At the end of the examination, fasten all your work securely together.

The number of marks is given in brackets [] at the end of each question or part question.

For Examiner's Use

This document consists of **16** printed pages.





Fig. 1 Map of the world

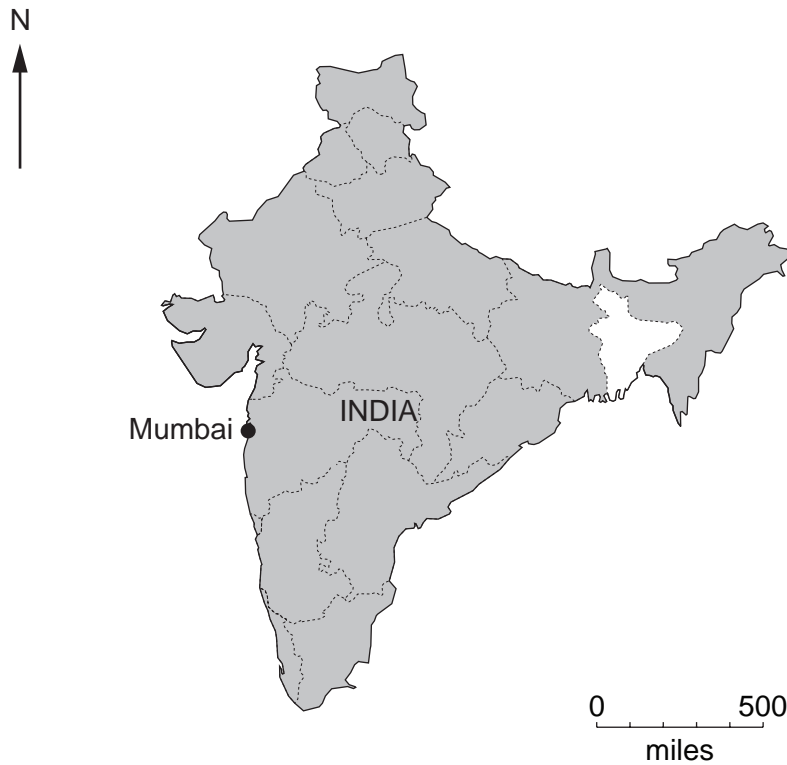

Fig. 2 Map of India

Area: 3287600sqkm

Population: 1.1 billion

Children per woman: 2.75

Life expectancy at birth: 64.7 yrs

Currency: rupee (44 rupees = 1US dollar)

Official languages: Hindi, English, 14 other languages

Climate: mainly tropical monsoon but temperate in the northern mountains

Terrain: mainly upland plateau with mountains in the north, Ganges Valley in between

Main exports: textiles, gems and jewellery, engineering goods, chemicals, leather goods

India has a diverse economy including traditional village farming, modern agriculture, handicrafts, a wide range of modern manufacturing and service industries. India has become a major exporter of computer software. The large and growing population continues to present social, economic and environmental problems.

- 1 Mumbai is a densely populated city; with its suburbs it has a population up to 20 million people. The city has a deep natural harbour and is the commercial and entertainment capital of India.



Fig. 3 Shipbreaking

Ship breaking takes place on plots rented for one year from the Mumbai Port Authority. Ships from all over the world are beached at high tide and cut up for scrap iron and other metals using large gas torch cutters.

This activity is not carefully regulated and people work up to 84 hours a week. They are given no safety training usually.

- (a) (i) About 3000 people are employed in ship breaking in Mumbai. The men earn 150 rupees a day. Each ship has a small team of women collecting scraps of metal, for which they earn 50 rupees a day. How much would be earned in seven days by

a man,

a woman?

[2]

(ii) Suggest why ships from around the World are sent to Mumbai to be cut up.

.....
..... [1]

(iii) Explain why ship breaking makes good use of resources.

.....
..... [2]

(iv) One shipbreaker said, 'You can leave for work on a ship in the morning but you never know if you will return home in the evening.'

Suggest why the worker said this.

.....
..... [2]

(b) Some samples of the beach were taken and analysed to see if the levels were above the danger level.

Toxic chemical substance	Site 1	Site 2	Site 3	Danger level
	level	level	level	
Mineral oil	3500	5500	4500	5000
Heavy metals	0.56	0.96	0.75	10.0
PAH's	7	9	11	40
PCB's	0.23	0.38	0.29	1.0
Organotin	3.31	7.33	5.61	0.0001

Fig. 4

(i) Which site was most polluted?

..... [1]

(ii) Which site is likely to have been used for the shortest time for ship breaking?

..... [1]

(iii) How does the information suggest that the PAH samples may be inaccurate?

.....
..... [1]

(iv) Complete the table below

	Toxic chemical substance
Most above danger level
Furthest below danger level

[2]

(v) Describe the possible effects of the toxic chemical substances on the workers.

.....

.....

..... [2]

(c) Look at Fig. 5, which shows the areas of ship breaking and mangroves.

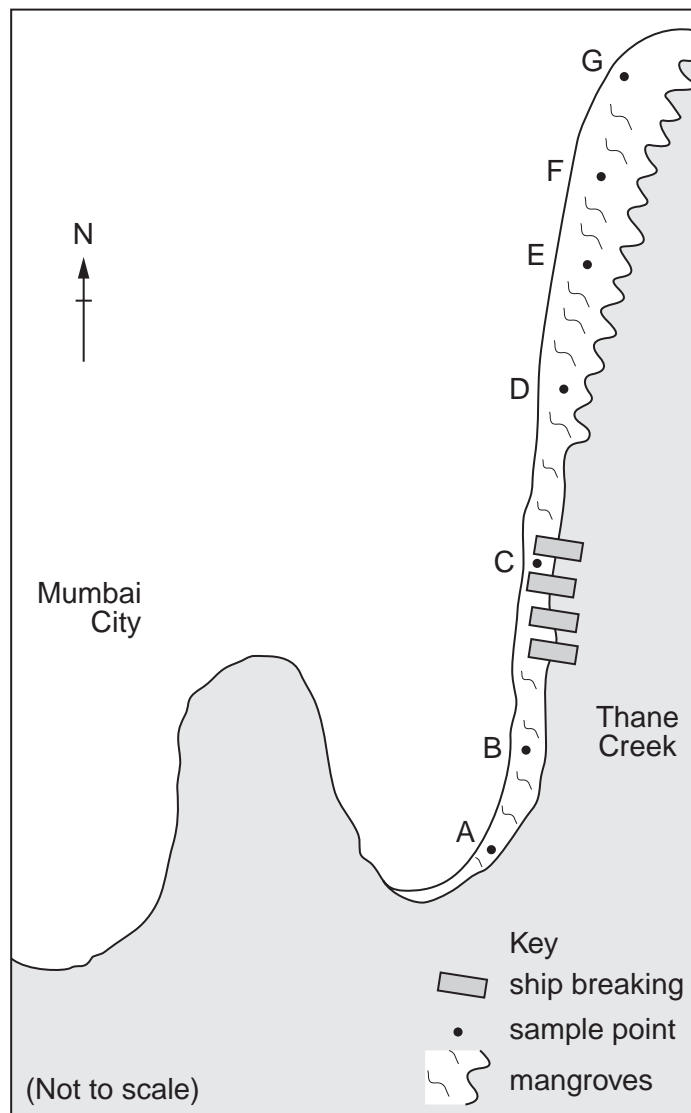

Fig. 5 shipbreaking coastal map

A scientist decided to repeat the sampling at the points shown in Fig. 5.

	Sample sites						
Toxic substance	A	B	C	D	E	F	G
Organotin	1.3	3.0	7.1	3.2	1.7	0.5	0.2
Heavy metals	0.2	0.4	1.0	0.8	0.4	0.2	0.1

(i) Plot the data on a graph.

[4]

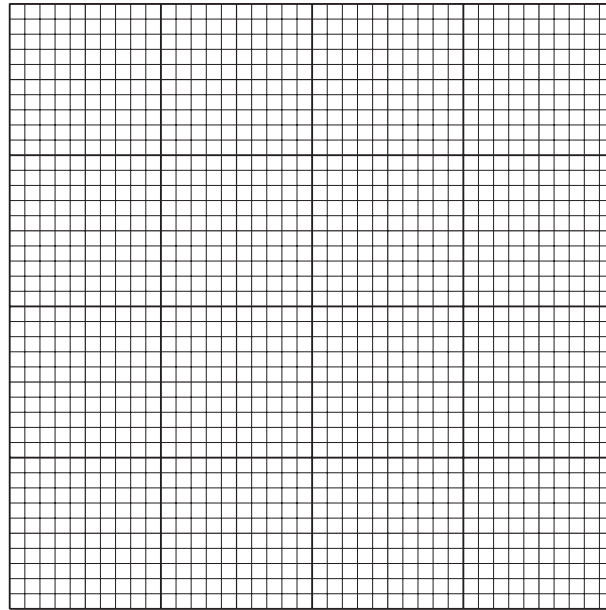

(ii) How does the graph indicate that ship breaking is the source of the toxic substances?

..... [1]

(iii) Suggest which substance spreads fastest. State the evidence that supports your answer.

.....
..... [1]

(d) Another scientist has been trying to protect the mangroves as they are an area of high biodiversity. The scientist is very worried that many species could die out.

(i) Explain why species in the mangrove ecosystem could die out.

.....
.....
..... [2]

(ii) Suggest why the Port Authority is likely to continue to give licences for ship breaking on the beach.

.....
..... [1]

(iii) How could the ship breaking continue with less danger to the marine environment?

.....
.....
..... [2]

- 2 (a) Dharavi is the largest slum in Mumbai. Originally it was a small fishing village. The commercial district of Mumbai has grown around the slum. Dharavi has many small industries earning 10 million rupees per year.

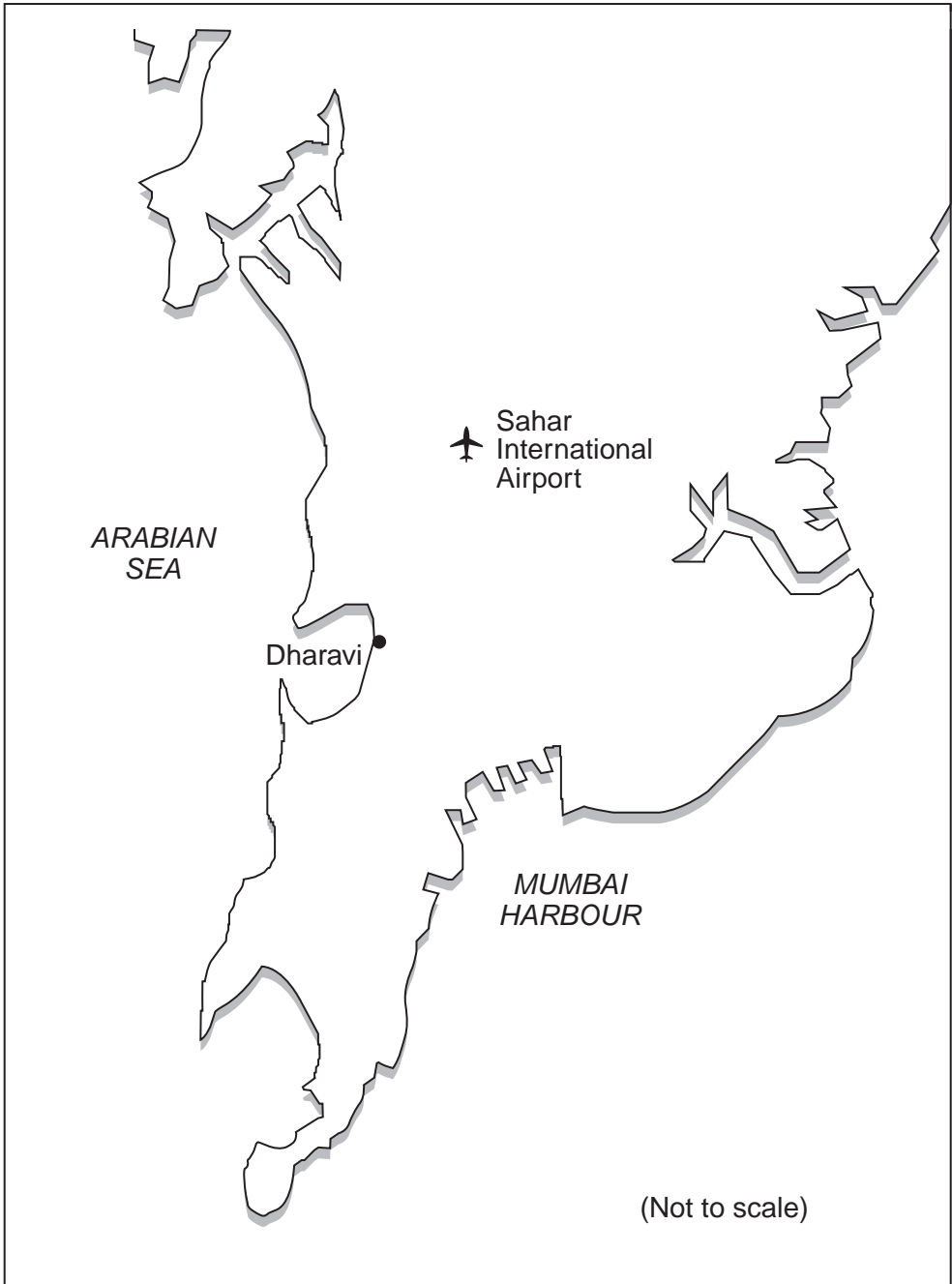

Fig. 6 Map to show location of Dharavi in city

- (i) Explain why people move to slums like Dharavi.

.....

.....

..... [2]

(ii) Explain why there is a very high employment rate for people living in Dharavi

.....

..... [1]

(iii) Name **two** diseases that would spread more easily during the wet monsoon months. Explain how each disease spreads.

disease

spread by

.....

disease

spread by

..... [2]

(iv) The slum is not very healthy because it has open drains. Explain why more people become ill during wet monsoon months.

.....

.....

..... [2]

(b) Fig. 7 shows one section of the slum which has developed an industry of washing.



Fig. 7 Picture of washing in Dharavi

This part of the slum has become permanent. Electricity and televisions are found in nearly all the dwellings.

(i) Explain why the city authorities will find it very difficult to develop this part of the slum.

.....
.....
..... [2]

(ii) Suggest why the slum dwellers do not want more help from the city authorities.

.....
.....
..... [2]

(iii) Explain why people live in slums like Dharavi for many years.

.....
.....
..... [2]

3 Some students of environmental management noticed that there was hardly any recycling in Mumbai City. Cardboard and plastic were being collected and sold for recycling. The students wanted to find out how much was being collected. Three plans were proposed to find out more about this recycling.

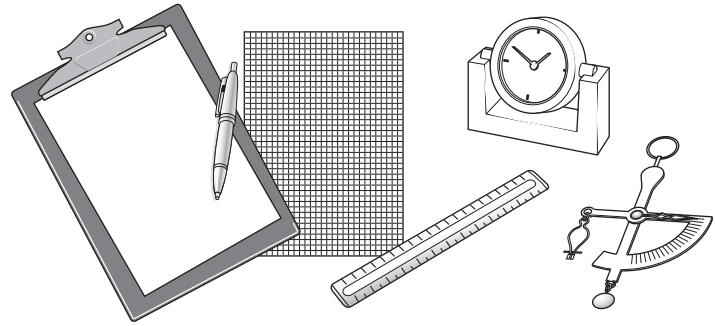

Fig. 8 Some equipment used by students

Plan One

A student stands at a point P and counts how many cardboard and plastic collectors can be seen in one hour. The student writes down how big a pile of material has been collected.

Plan Two

There are four students; one of them stands at each of four sample points P, Q, R and S for three hours. The students asks each collector to tell them the weight of cardboard collected.

Plan Three

There are four students; one student stands at each of four samples points P, Q, R and S for three hours. The students weighed all the cardboard and plastic.

(a) (i) Why is Plan One unreliable?

..... [1]

(ii) Explain why Plan Two is an improvement on Plan One.

.....
..... [2]

(iii) Explain why Plan Three is the best.

.....
..... [1]

(b) The students using Plan Three put the results into the table shown in Fig. 9.

Material collected in one day at each sample position

Sample position	P	Q	R	S	Total collected kg
Cardboard kg	4	11	6	9	30
Plastic kg	5	8	7	5	25

Fig. 9

Plastic can be sold for 15 rupees per kilogram and cardboard for 5 rupees per kilogram.

Calculate the total value of the collected material in this study.

.....

..... [2]

(c) The average amount of garbage per person in greater Mumbai is 500g per day. This is predicted to double by 2050. All the garbage cannot be buried or burnt in greater Mumbai.

(i) Explain why the burning and burying of garbage cannot continue.

.....

.....

..... [2]

The Clean Mumbai Foundation has set up trials to deal with wet garbage. Composting pits have been built in parks. Many trees have been planted in the parks to give shade.

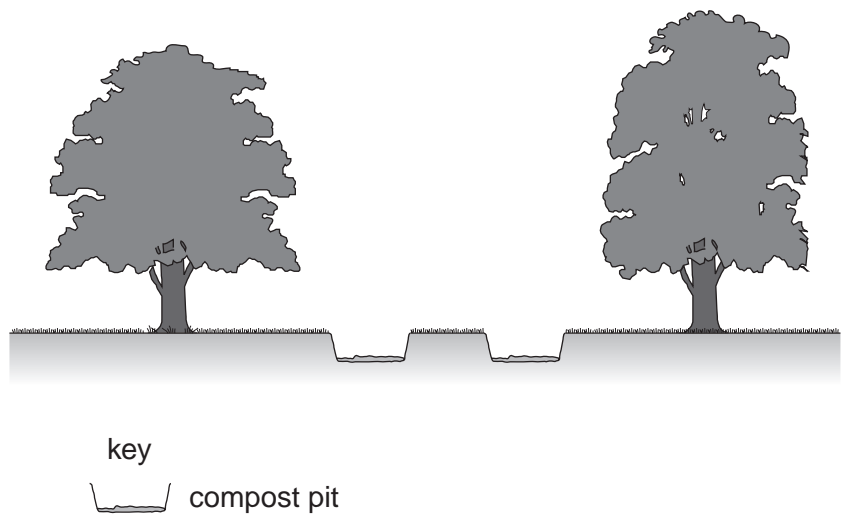

Fig. 10

(ii) Describe the biological processes taking place in the pits.

.....
.....
.....[2]

A Pavement Tank Method has also been trialled. Brick tanks are built next to trees in high-rise residential areas.

A resident said 'wet garbage is put in the tanks and covered by dried leaves to stop the smell. We have to keep stray dogs and cattle away'.

Another resident said 'the trees are important on our streets, they give shade and keep the street cool'.

(iii) Describe the advantages and disadvantages of the Pavement Tank Method over the landfill method.

advantages

.....
.....

disadvantages

.....
.....[3]

(d) An environmental management student wanted to find out if trees really did keep cool. The study area is shown in Fig. 11.

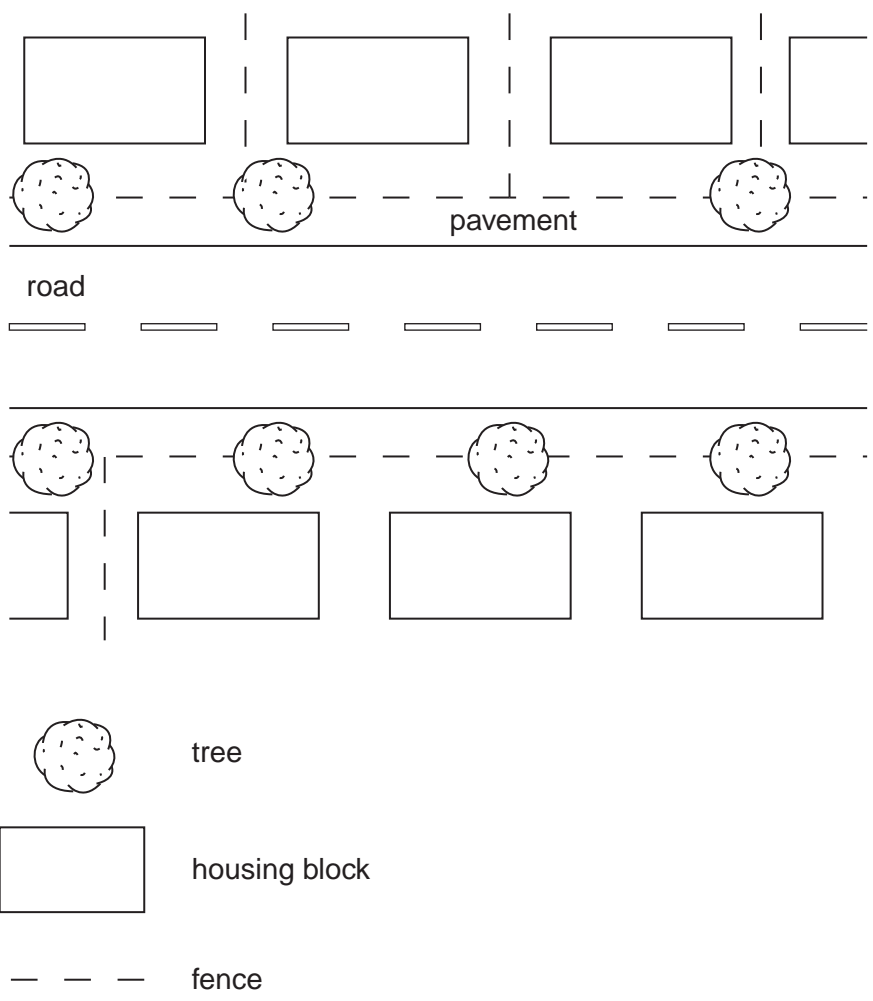

Fig. 11

The student has four thermometers and four volunteers to take the readings. The student tells them to each take eight readings.

(i) Place an X on Fig. 11 in four places, to show a good position for each thermometer. [2]

(ii) Suggest **two** ways the student can make sure this experiment is accurately carried out.

.....
.....
..... [2]

(iii) Draw a table in the space below to show how the readings should be recorded.

[3]

(e) Explain why the city authorities should encourage tree planting instead of people buying electrical air conditioning units.

.....

.....

..... [2]

Copyright Acknowledgements:

Question 2 (b) Fig. 7; John Stacey © UCLES.

Permission to reproduce items where third-party owned material protected by copyright is included has been sought and cleared where possible. Every reasonable effort has been made by the publisher (UCLES) to trace copyright holders, but if any items requiring clearance have unwittingly been included, the publisher will be pleased to make amends at the earliest possible opportunity.

University of Cambridge International Examinations is part of the Cambridge Assessment Group. Cambridge Assessment is the brand name of University of