



Cambridge International Examinations
Cambridge International General Certificate of Secondary Education

CANDIDATE
NAME

CENTRE
NUMBER

| | | | | |
|--|--|--|--|--|
| | | | | |
|--|--|--|--|--|

CANDIDATE
NUMBER

| | | | |
|--|--|--|--|
| | | | |
|--|--|--|--|



GEOGRAPHY

0460/12

Paper 1

February/March 2017

1 hour 45 minutes

Candidates answer on the Question Paper.

Additional Materials: Ruler
 Calculator

READ THESE INSTRUCTIONS FIRST

Write your Centre number, candidate number and name in the spaces provided.

Write in dark blue or black pen.

You may use an HB pencil for any diagrams or graphs.

Do not use staples, paper clips, glue or correction fluid.

DO **NOT** WRITE IN ANY BARCODES.

Write your answer to each question in the space provided.

If additional space is required, you should use the lined pages at the end of this booklet. The question number(s) must be clearly shown.

Answer **three** questions, **one** from each section.

The Insert contains Photograph A for Question 2, Fig. 5 and Photograph B for Question 3, Photograph C for Question 5 and Photograph D for Question 6.

The Insert is **not** required by the Examiner.

Sketch maps and diagrams should be drawn whenever they serve to illustrate an answer.

At the end of the examination, fasten all your work securely together.

The number of marks is given in brackets [] at the end of each question or part question.

Definitions

MEDCs – More Economically Developed Countries

LEDCs – Less Economically Developed Countries

The syllabus is approved for use in England, Wales and Northern Ireland as a Cambridge International Level 1/Level 2 Certificate.

This document consists of **27** printed pages, **1** blank page and **1** Insert.

Section A

Answer **one** question from this section.

QUESTION 1

1 (a) Study Fig. 1, which shows information about international migration to four MEDCs.

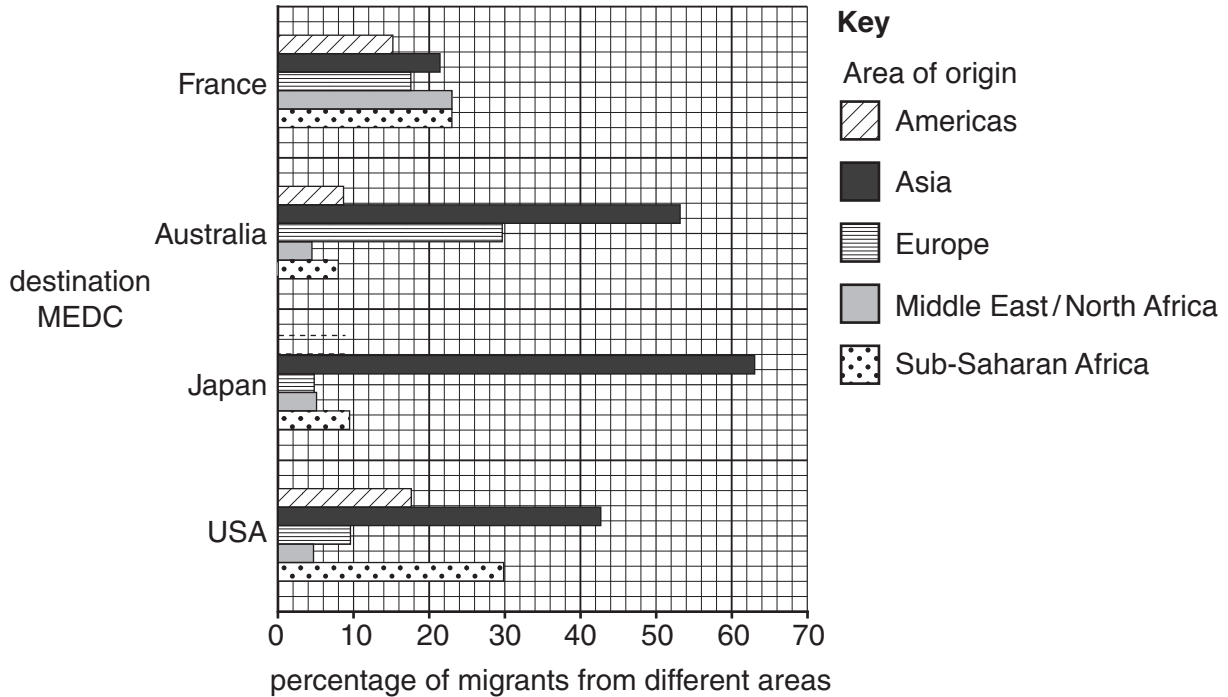

Fig. 1

(i) Complete the bar for Japan to show the following information:

20% of migrants to Japan are from the Americas. [1]

(ii) Identify the country which attracts:

- the greatest percentage of migrants from Asia;
- the same percentage of migrants from the Middle East/North Africa and Sub-Saharan Africa. [2]

QUESTION 2

- 2 (a) Study Fig. 3 and Photograph A (Insert). Fig. 3 shows information about an improvement project in Porto, a city in Portugal (an MEDC in Europe). Photograph A (Insert) shows an area of housing in the Bairro da Sé district in Porto.

| | |
|---|---|
| <p>The Porto Urban Pilot Project focused on the historic “Bairro da Sé” district, close to the centre of the city. The neighbourhood had been one of the most deprived districts in Porto, with poor-quality housing, overcrowding, high crime rates and drug abuse. The project aimed to solve these problems through measures designed to improve the urban environment, create economic activity in the area and integrate the socially excluded into neighbourhood life. At the same time, the project aimed to introduce measures which fully respected, maintained and even enhanced the area’s cultural identity and heritage.</p> |  |
|---|---|

Fig. 3

- (i) In which **one** of the following urban zones is Bairro da Sé?

Underline your answer.

Central Business District (CBD)

Inner city

Outer suburbs

Rural-urban fringe

[1]

- (ii) Using Fig. 3 **only**, identify **two** urban problems in Bairro da Sé.

1

2 [2]

- (iii) Part of Bairro da Sé is shown in Photograph A (Insert). Describe **three** features of the housing shown.

1

.....

2

.....

3

..... [3]

Section B

Answer **one** question from this section.

QUESTION 3

3 (a) Study Fig. 5 (Insert), which is a map of the Kelantan drainage basin in Malaysia (an LEDC in Asia).

(i) What is meant by a *drainage basin*?

.....
.....[1]

(ii) In December 2014 flooding occurred in many parts of the Kelantan drainage basin. Using evidence from Fig. 5 **only**, suggest **two** reasons why flooding is more likely in area X than Y.

1
.....
2
.....[2]

(iii) Suggest **three** different hazards which are likely to have been caused by flooding in area X in December 2014.

1
.....
2
.....
3
.....[3]

QUESTION 4

4 (a) Study Fig. 6, which shows a cross section of an area affected by an earthquake.

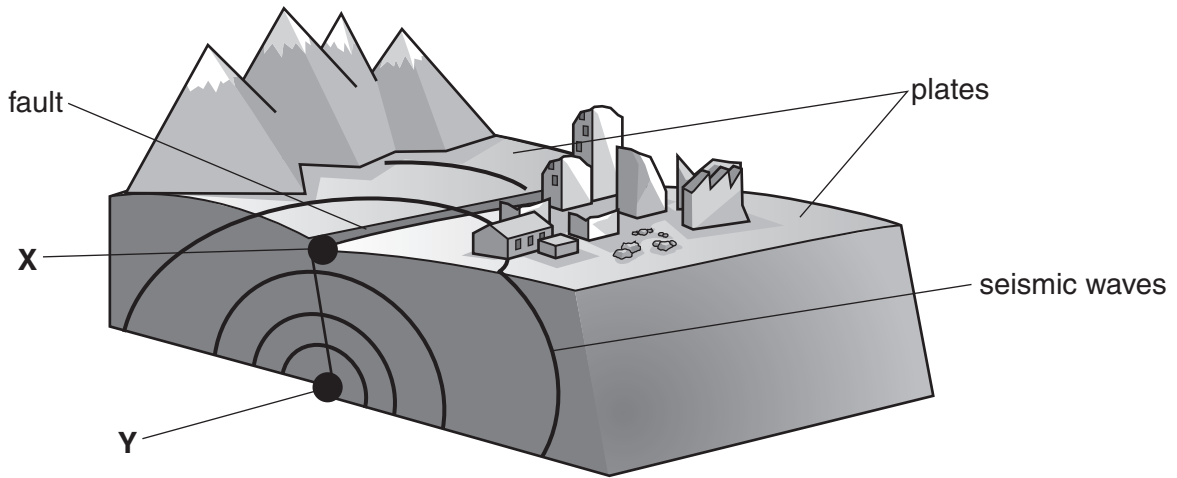

Fig. 6

(i) Tick the **one** statement in the table below which is the correct definition of an earthquake.

| | |
|--|--------------------------|
| A fracture in the rocks which make up the Earth's crust | <input type="checkbox"/> |
| A weakness in the Earth's crust through which molten magma erupts | <input type="checkbox"/> |
| Large slabs of rock which make up the outer layer of the Earth's surface | <input type="checkbox"/> |
| The shaking of the ground caused by sudden movement in the Earth's crust | <input type="checkbox"/> |

[1]

(ii) Identify the features of an earthquake labelled **X** and **Y** on Fig. 6.

X

Y

[2]

(iii) Describe **three** different hazards faced by people who live in areas affected by earthquakes.

1

.....

2

.....

3

.....[3]

(iv) State and explain **two** ways which can be used to reduce the impacts of earthquakes.

1

.....

.....

.....

.....

2

.....

.....

.....

.....[4]

(b) Study Fig. 7, which shows the global distribution of earthquakes (of 2.5 or more on the Richter Scale) between April 16th and May 13th 2013.

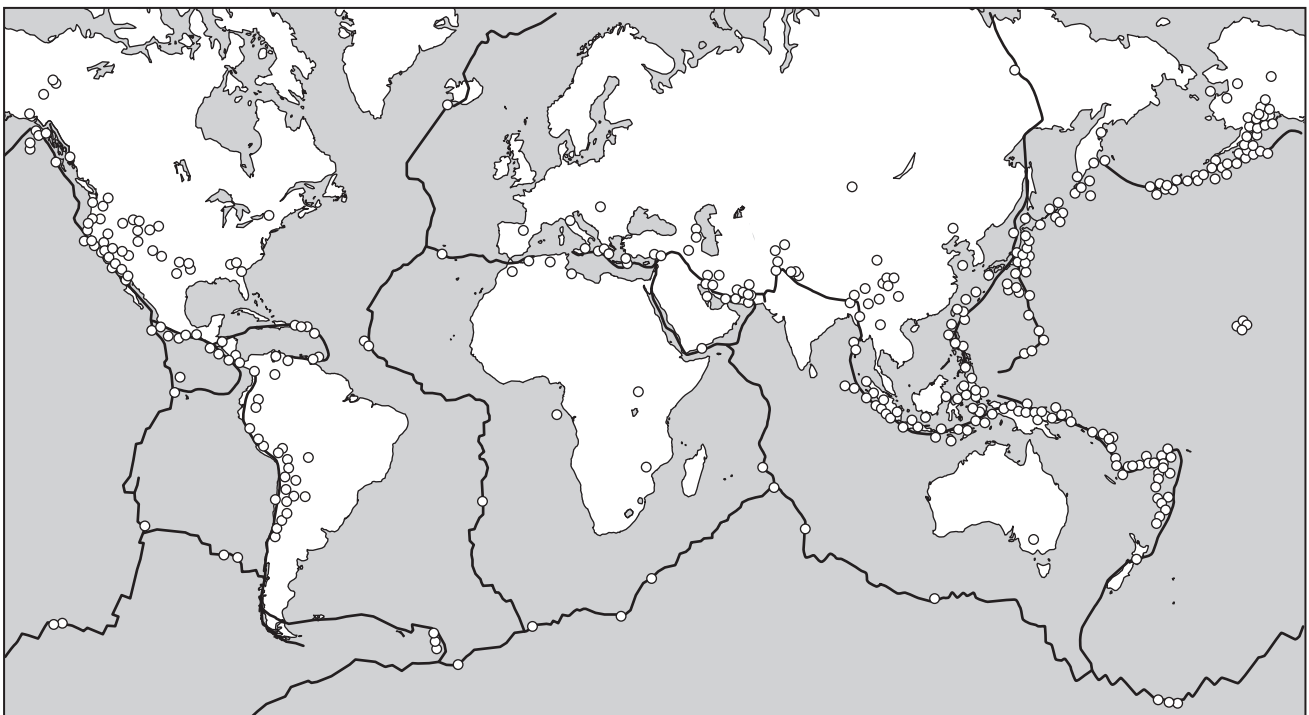

Key
○ earthquake of 2.5 or more on Richter Scale
~ plate boundary

Fig. 7

TURN PAGE FOR QUESTION 5

Section C

Answer **one** question from this section.

QUESTION 5

- 5 (a) Study Figs. 8A and 8B, which are maps showing information about domestic and international tourism in India.

Content removed due to copyright restrictions.

Content removed due to copyright restrictions.

(i) Complete Fig. 8B using the following information. Use the key provided.

The percentage of international tourists visiting Maharashtra is 21%. [1]

(ii) Explain the difference between the terms *domestic* and *international* tourist.

.....
.....
.....
..... [2]

(iii) Using Figs. 8A and 8B **only**, name a state which:

- has between 10.1% and 20% of both domestic and international tourists;

.....

- has a greater percentage of international than domestic tourists;

.....

- has the largest percentage of domestic tourists.

.....

[3]

(iv) Explain why the growth of tourism in an area leads to the development of its infrastructure.

.....
.....
.....
.....
.....
.....
.....
.....
.....
.....

[4]

(b) Study Photograph C (Insert), which was taken in Mauritius, an island in the Indian Ocean which is visited by many tourists from countries in Europe, such as the UK and Germany.

(i) Describe the **physical** attractions for tourists from Europe which are shown in Photograph C.

.....
.....
.....
.....
.....
.....[3]

(ii) Explain how the human landscape can also attract tourists to an area.

.....
.....
.....
.....
.....
.....
.....
.....
.....
.....
.....
.....[5]

QUESTION 6

6 (a) Study Fig. 9, which shows information about the employment structure of two European countries, France and Italy.

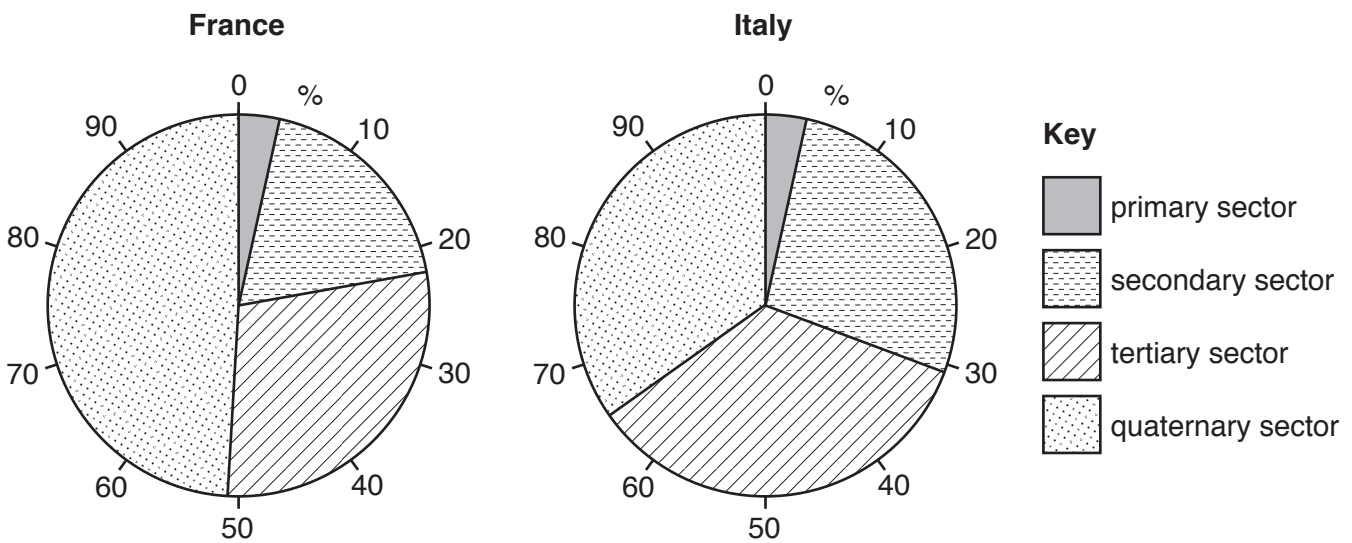

Fig. 9

(i) What percentage of the workforce of France is employed in the secondary sector?

..... %

[1]

(ii) Which sector:

– employs the smallest percentage in both France and Italy;

.....

– employs a larger percentage of the workforce in France than in Italy?

.....

[2]

(iii) Match each example of a job in the table below with the correct sector by using arrows. The first one has been completed for you.

| Example of job | Sector |
|--|------------|
| School teacher | Primary |
| Research worker for a firm making computer software | Secondary |
| Workers harvesting tea on a plantation | Tertiary |
| Worker on the production line in a factory making jam. | Quaternary |

[3]

(iv) Explain why quaternary industry has become important in countries where economic development is rapid.

.....
.....
.....
.....
.....
.....
.....
.....
.....
.....[4]

(b) Study Photograph D (Insert), which was taken in Madeira, an island in the Atlantic Ocean.

(i) State **three** different types of job created by the economic activity shown in the photograph.

1
2
3[3]

(ii) Suggest how the economic activity shown in Photograph D could pose threats to the natural environment.

.....
.....
.....
.....
.....
.....
.....
.....
.....
.....
.....
.....
.....
.....
.....
.....
.....
.....
.....
.....
.....[5]

BLANK PAGE

Permission to reproduce items where third-party owned material protected by copyright is included has been sought and cleared where possible. Every reasonable effort has been made by the publisher (UCLES) to trace copyright holders, but if any items requiring clearance have unwittingly been included, the publisher will be pleased to make amends at the earliest possible opportunity.

To avoid the issue of disclosure of answer-related information to candidates, all copyright acknowledgements are reproduced online in the Cambridge International Examinations Copyright Acknowledgements Booklet. This is produced for each series of examinations and is freely available to download at www.cie.org.uk after the live examination series.

Cambridge International Examinations is part of the Cambridge Assessment Group. Cambridge Assessment is the brand name of University of Cambridge Local Examinations Syndicate (UCLES), which is itself a department of the University of Cambridge.