



UNIVERSITY OF CAMBRIDGE INTERNATIONAL EXAMINATIONS  
International General Certificate of Secondary Education

CANDIDATE NAME

CENTRE NUMBER

CANDIDATE NUMBER

\* 1 1 7 0 6 4 2 3 3 2 \*

**CAMBRIDGE INTERNATIONAL MATHEMATICS**

**0607/41**

Paper 4 (Extended)

**May/June 2013**

**2 hours 15 minutes**

Candidates answer on the Question Paper.

Additional Materials: Geometrical Instruments  
Graphics Calculator

**READ THESE INSTRUCTIONS FIRST**

Write your Centre number, candidate number and name on all the work you hand in.

Write in dark blue or black pen.

Do not use staples, paper clips, highlighters, glue or correction fluid.

You may use a pencil for any diagrams or graphs.

**DO NOT WRITE IN ANY BARCODES.**

Answer **all** the questions.

Unless instructed otherwise, give your answers exactly or correct to three significant figures as appropriate.

Answers in degrees should be given to one decimal place.

For  $\pi$ , use your calculator value.

You must show all the relevant working to gain full marks and you will be given marks for correct methods, including sketches, even if your answer is incorrect.

The number of marks is given in brackets [ ] at the end of each question or part question.

The total number of marks for this paper is 120.

**For Examiner's Use**

--

This document consists of **16** printed pages.



## Formula List

For the equation

$$ax^2 + bx + c = 0$$

$$x = \frac{-b \pm \sqrt{b^2 - 4ac}}{2a}$$

Curved surface area,  $A$ , of cylinder of radius  $r$ , height  $h$ .

$$A = 2\pi rh$$

Curved surface area,  $A$ , of cone of radius  $r$ , sloping edge  $l$ .

$$A = \pi rl$$

Curved surface area,  $A$ , of sphere of radius  $r$ .

$$A = 4\pi r^2$$

Volume,  $V$ , of pyramid, base area  $A$ , height  $h$ .

$$V = \frac{1}{3}Ah$$

Volume,  $V$ , of cylinder of radius  $r$ , height  $h$ .

$$V = \pi r^2 h$$

Volume,  $V$ , of cone of radius  $r$ , height  $h$ .

$$V = \frac{1}{3}\pi r^2 h$$

Volume,  $V$ , of sphere of radius  $r$ .

$$V = \frac{4}{3}\pi r^3$$

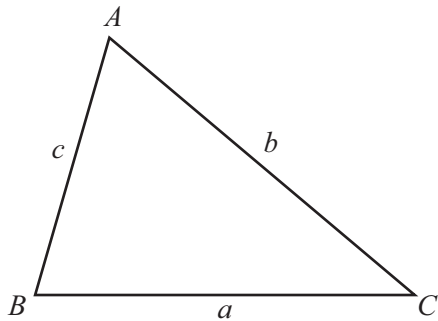

$$\frac{a}{\sin A} = \frac{b}{\sin B} = \frac{c}{\sin C}$$

$$a^2 = b^2 + c^2 - 2bc \cos A$$

$$\text{Area} = \frac{1}{2}bc \sin A$$

Answer **all** the questions.

**1** Each year the value of a car decreases by 12%.  
On 1st April 2011 Sami bought a car for \$15 840.

**(a)** Work out

**(i)** the value of the car on 1st April 2010,

*Answer(a)(i)* \$ ..... [3]

**(ii)** the value of the car on 1st April 2014,

*Answer(a)(ii)* \$ ..... [3]

**(iii)** the year in which the value of the car will first be below \$5000.

*Answer(a)(iii)* ..... [2]

**(b)** Each year Sami drives 20 000 km in his car.  
His yearly motoring costs are

- fuel at \$0.68 per litre,
- service and other repairs \$950,
- tax and insurance \$1020.

The car travels 15 km on each litre of fuel.

Find the total yearly motoring costs as a percentage of the value of the car in 2011.

*Answer(b)* ..... % [4]

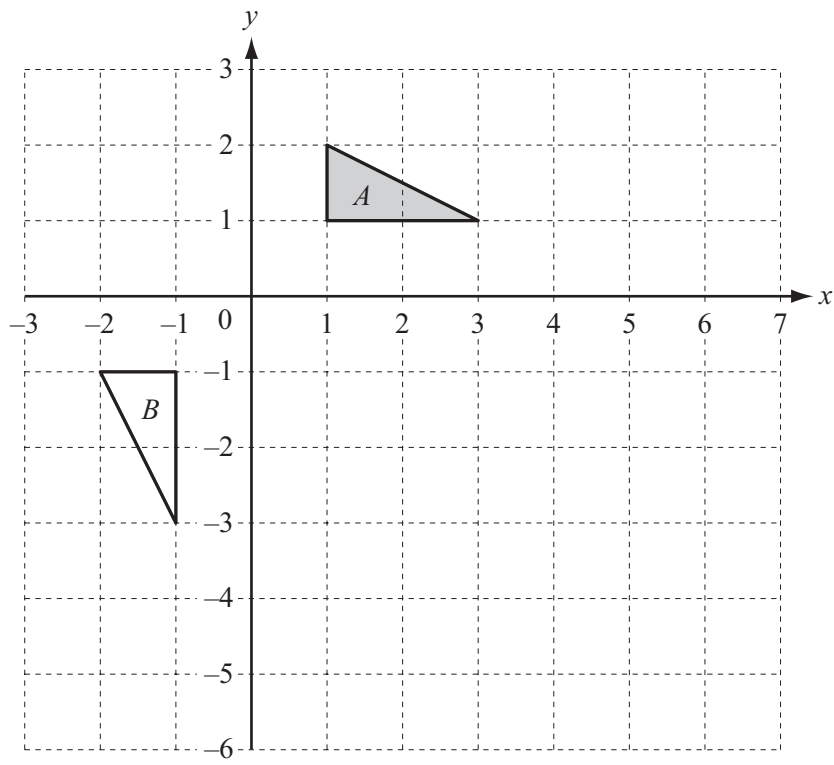

(a) Describe fully the **single** transformation that maps triangle *A* onto triangle *B*.

Answer(a) .....  
..... [2]

(b) (i) Rotate triangle *A* through  $180^\circ$  about the point (3, 0). Label the image *C*. [2]

(ii) Enlarge triangle *C* with scale factor 2 and centre (6, 0). Label the image *D*. [2]

(iii) Describe fully the **single** transformation that maps triangle *A* onto triangle *D*.

Answer(b)(iii) .....  
..... [3]

3

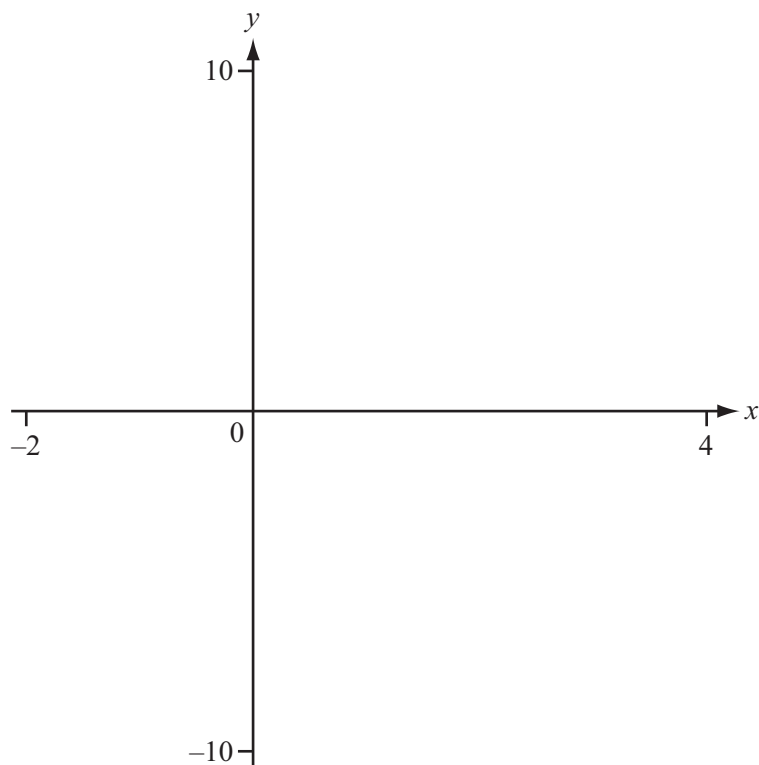

(a) On the diagram, sketch the graph of  $y = x^3 - 3x^2 + 2$  for  $-2 \leq x \leq 4$ . [2]

(b) Solve the equation  $x^3 - 3x^2 + 2 = 0$ .

Answer(b)  $x =$  .....

or  $x =$  .....

or  $x =$  ..... [2]

(c) (i) Find the co-ordinates of the local maximum and local minimum points.

Answer(c)(i) ( ..... , ..... )

( ..... , ..... ) [2]

(ii) The equation  $x^3 - 3x^2 + 2 = k$  has 3 solutions.  
Write down the range of values for  $k$ .

Answer(c)(ii) ..... [2]

(d) By drawing a suitable line on your diagram show that  $x^3 - 3x^2 + 2 = 6 - 3x$  has only one solution. [2]

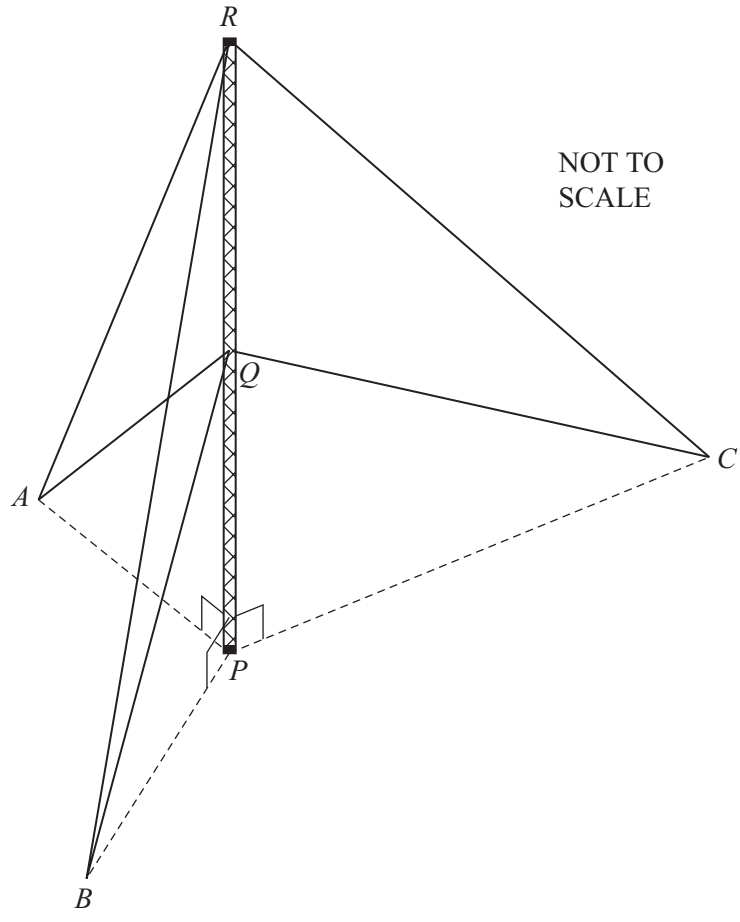

NOT TO SCALE

The diagram shows a vertical radio mast  $PQR$  supported by 6 straight wires.  
 $A, B, C$  and  $P$  are on level horizontal ground.  
 $RA = RB = RC$  and  $QA = QB = QC$ .  
 $PQ = 30$  m,  $QR = 20$  m and angle  $AQP =$  angle  $BQP =$  angle  $CQP = 65^\circ$ .

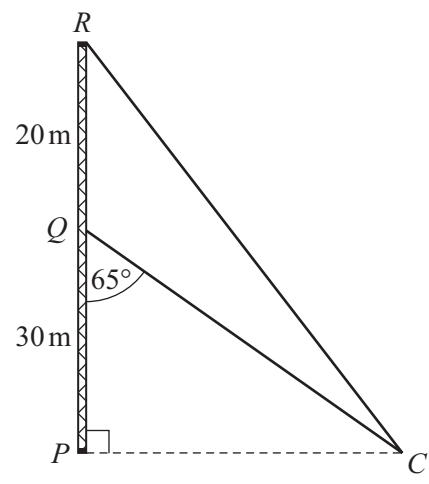

NOT TO SCALE

(a) Show that  $QC = 70.99$  m, correct to 2 decimal places.

[2]

(b) Using the cosine rule, calculate the length  $RC$ .

Answer(b) ..... m [3]

(c) Find the **total** length of the 6 wires.

Answer(c) ..... m [1]

(d) Calculate the length  $PC$ .

Answer(d) ..... m [2]

(e) This is a view from above showing  $A, B, P$  and  $C$  on horizontal ground.

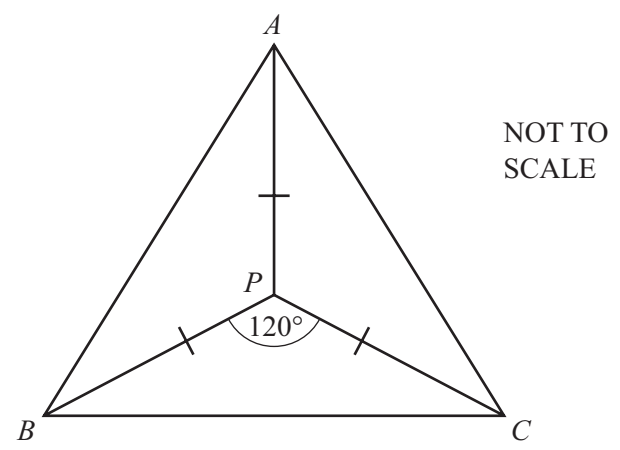

Calculate the area of triangle  $BPC$ .

Answer(e) ..... m<sup>2</sup> [2]

5

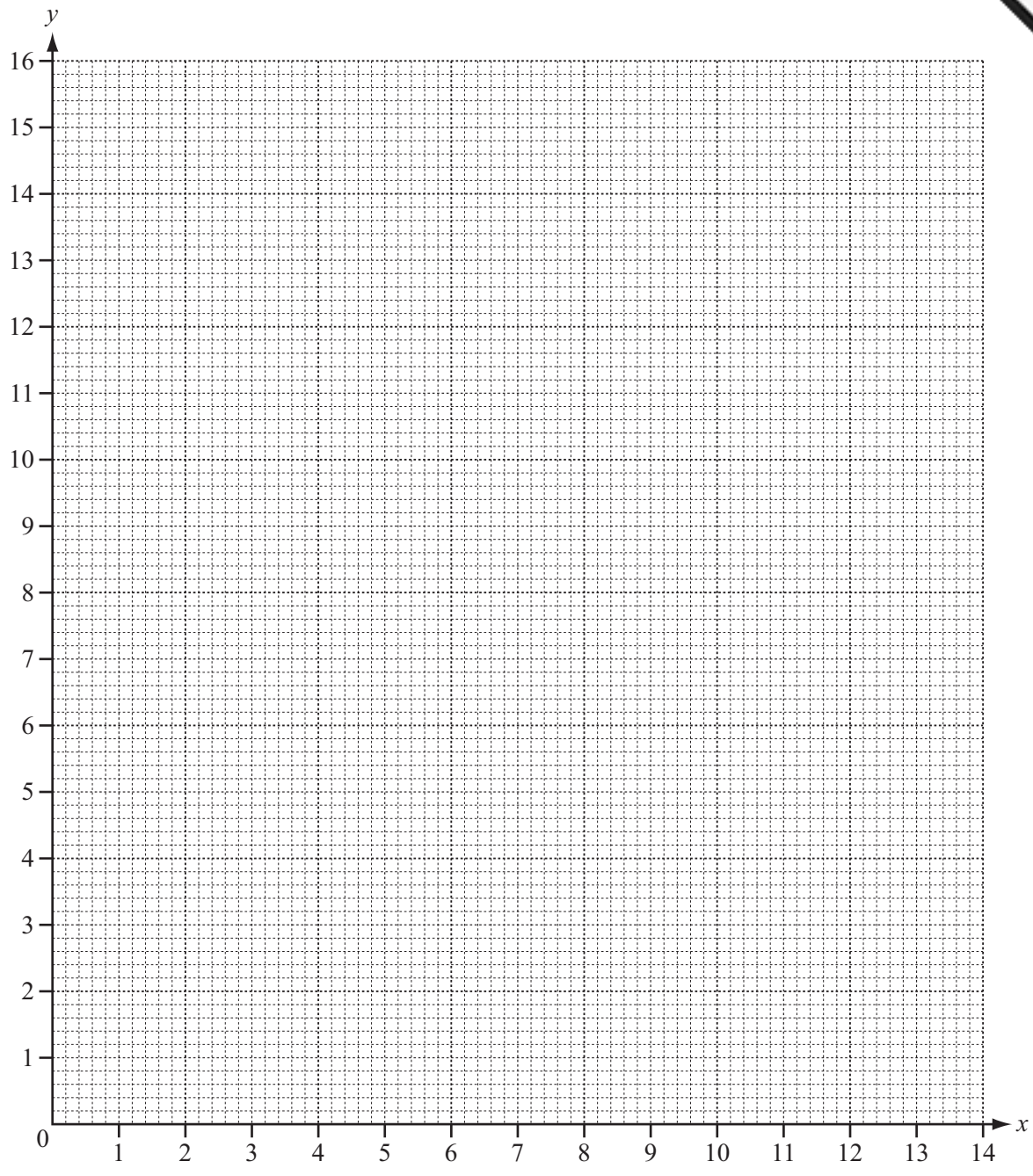

(a) On the grid, find the region satisfied by the following inequalities.  
Label the region R.

$x \leq 4$                    $x + y \leq 12$                    $5x + 2y \geq 30$                   [5]

(b)  $(h, k)$  is a point in the region R and  $h$  and  $k$  are integers.

(i) Find the number of possible points  $(h, k)$ .

Answer(b)(i) ..... [1]

(ii) Find the minimum value of  $h + k$ .

Answer(b)(ii) ..... [1]



6

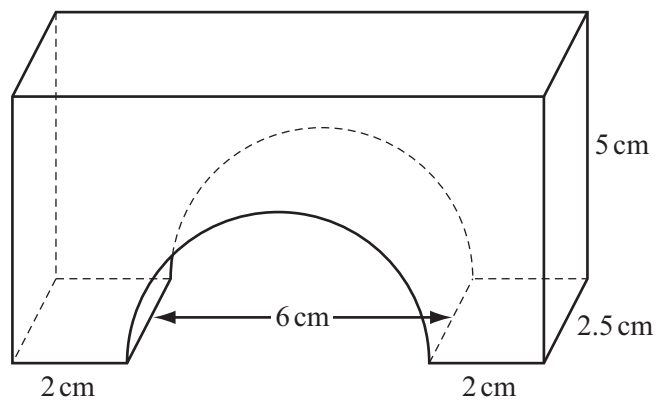

NOT TO  
SCALE

The diagram shows a child's wooden brick.  
 The brick is a cuboid with a semicircular hole cut in the bottom.

(a) Find the volume of the brick.

Answer(a) ..... cm<sup>3</sup> [3]

(b) Each cubic centimetre of wood has a mass of 0.8 g.  
 Find the mass of the brick.

Answer(b) ..... g [1]

(c) Find the **total** surface area of the brick.

Answer(c) ..... cm<sup>2</sup> [5]

7 (a) The speeds,  $v$  km/h, of 140 cars were measured on road A.

The cumulative frequency graph shows the speeds of these cars.

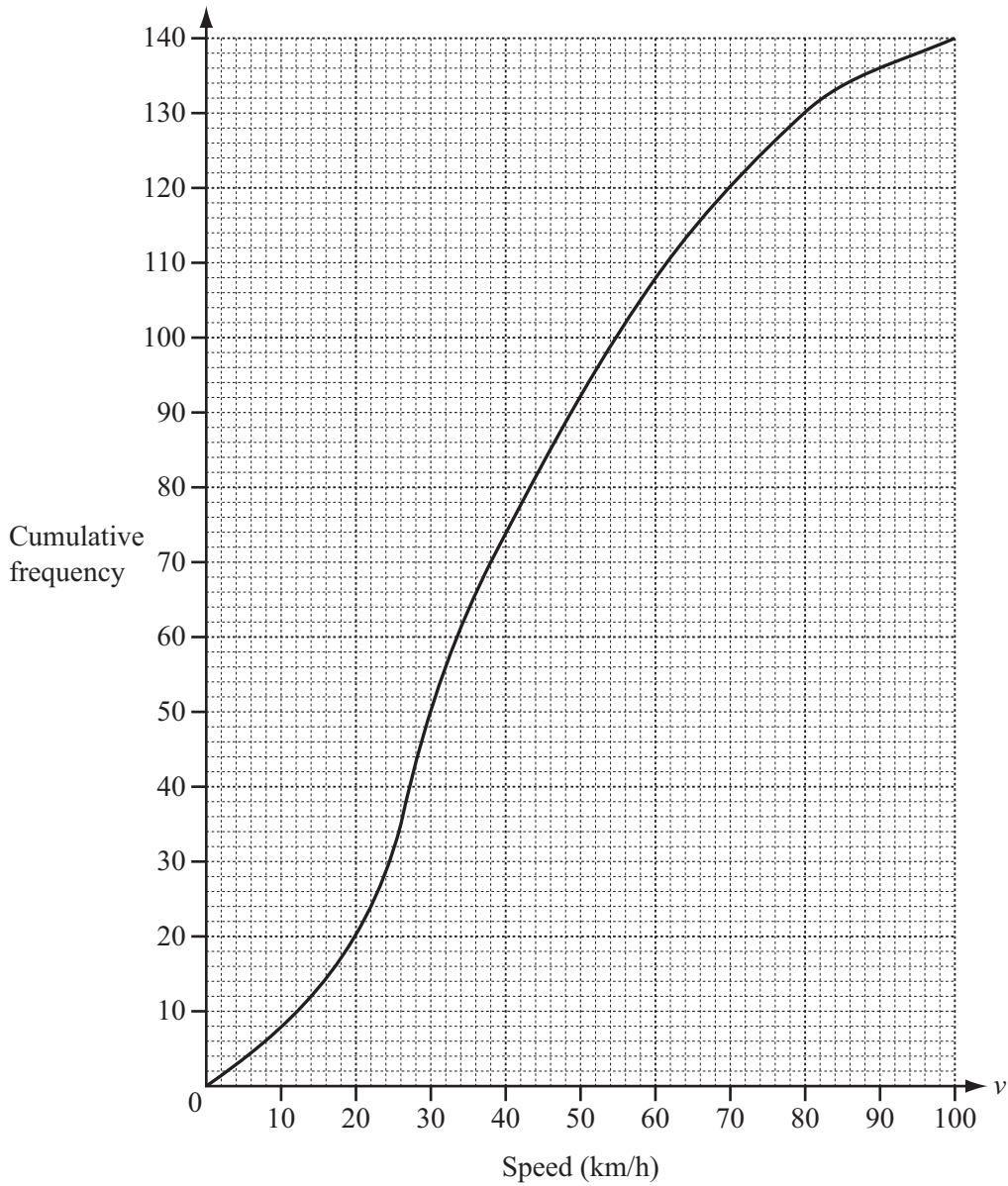

(i) Find the median speed.

Answer(a)(i) ..... km/h [1]

(ii) Find the inter-quartile range of the speeds.

Answer(a)(ii) ..... km/h [2]

(b) The speeds of another 140 cars were measured on road B.  
The results are shown in this table.

Speed ( $v$ km/h)	$20 < v \leq 30$	$30 < v \leq 40$	$40 < v \leq 45$	$45 < v \leq 50$	$50 < v \leq 60$	$60 < v \leq 80$	$80 < v \leq 100$
Frequency	6	12	15	20	32	30	25

(i) Complete this table of cumulative frequencies for road B.

Speed ( $v$ km/h)	$v \leq 20$	$v \leq 30$	$v \leq 40$	$v \leq 45$	$v \leq 50$	$v \leq 60$	$v \leq 80$	$v \leq 100$
Cumulative frequency	0	6	18					140

[2]

(ii) On the grid in **part (a)**, draw the cumulative frequency curve for **road B**.

[3]

(iii) Make a comparison between the distributions of speeds on roads A and B.

Answer(b)(iii) .....

..... [2]

(iv) Calculate an estimate for the mean speed of the 140 cars on **road B**.

Answer(b)(iv) ..... km/h [2]

(v) On the grid below, complete the histogram to show the speeds of the cars on **road B**.

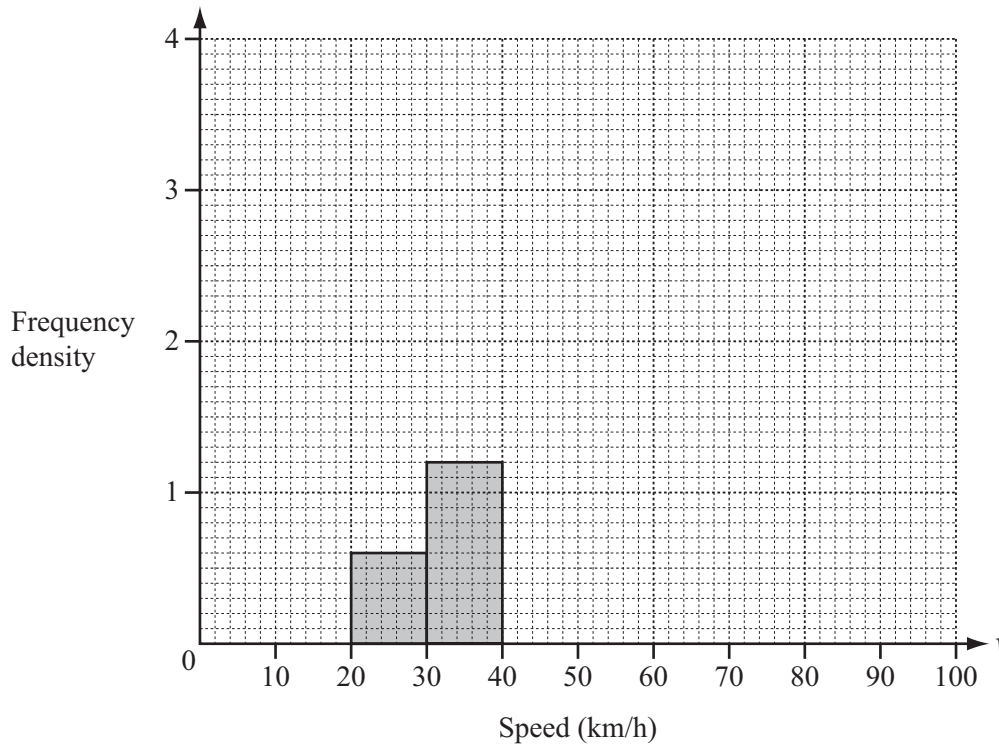

[4]

8 The table shows the number of left-handed and right-handed girls and boys in a class.

	Left-handed	Right-handed	Total
Girls	4	14	18
Boys	3	11	14
Total	7	25	32

(a) Two students are chosen at random from the whole class.  
Find the probability that they are both left-handed.

*Answer(a)* ..... [2]

(b) Two of the girls are chosen at random.  
Find the probability that exactly one of these girls is left-handed.

*Answer(b)* ..... [3]

(c) Two of the right-handed students are chosen at random.  
Find the probability that at least one is a girl.

*Answer(c)* ..... [3]

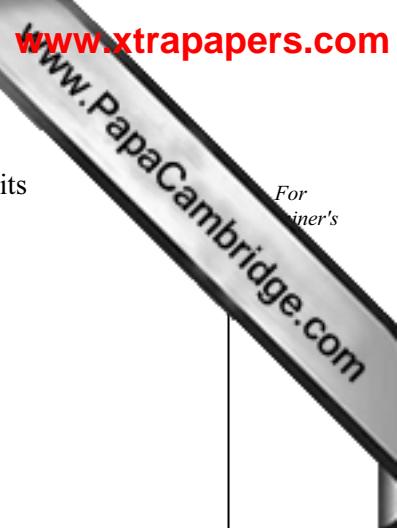

9 The resistance,  $R$  ohms, of a standard length of wire varies inversely as the square of its diameter,  $d$  mm.

(a) The resistance of a standard length of wire of diameter 0.5 mm is 0.8 ohms.

(i) Find a formula for  $R$  in terms of  $d$ .

Answer(a)(i)  $R = \dots\dots\dots$  [3]

(ii) Find the resistance of a standard length of the same type of wire with diameter 2 mm.

Answer(a)(ii)  $\dots\dots\dots$  ohms [1]

(iii) The resistance of a standard length of the same type of wire is 4 ohms. Find the diameter of this wire.

Answer(a)(iii)  $\dots\dots\dots$  mm [2]

(b) For a different type of wire the resistance of a standard length is 2 ohms. Find the resistance of a standard length of this wire when the diameter is doubled.

Answer(b)  $\dots\dots\dots$  ohms [2]

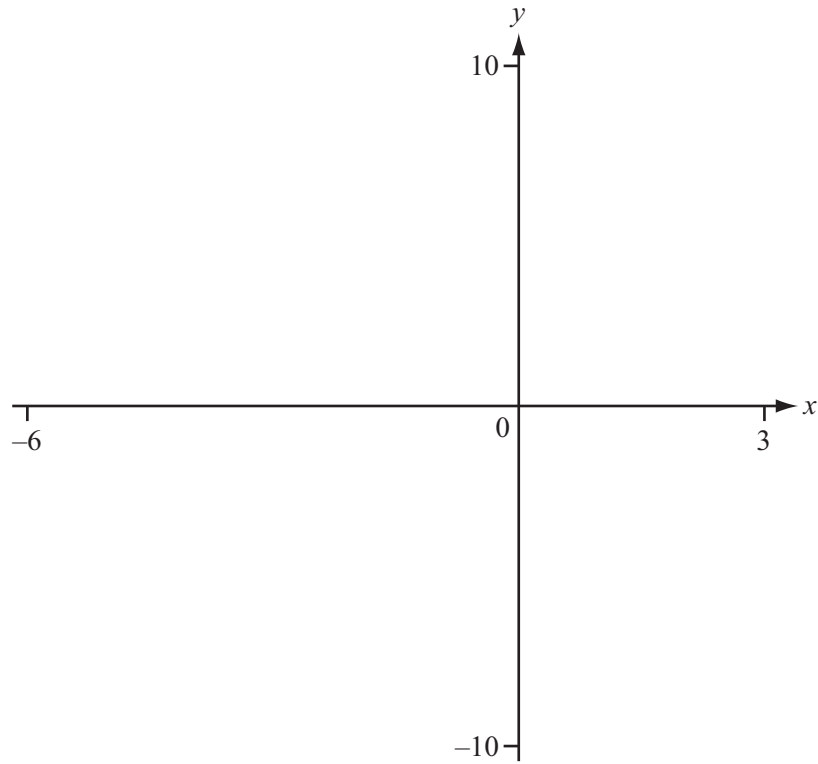

(a) On the diagram, sketch the graph of  $y = f(x)$ , where

$$f(x) = \frac{(x-1)}{(x+3)} \quad \text{between } x = -6 \text{ and } x = 3. \quad [3]$$

(b) Find the co-ordinates of the point where the graph crosses the  $x$ -axis.

Answer(b) ( ..... , ..... ) [1]

(c) Find the equations of the asymptotes of  $y = f(x)$ .

Answer(c) ..... and ..... [2]

(d) Find the range of  $f(x)$  for  $x \geq 0$ .

Answer(d) ..... [2]

(e) Find the solutions to the equation  $\frac{(x-1)}{(x+3)} = -5 - 2x$ .

Answer(e)  $x = \dots\dots\dots$  or  $x = \dots\dots\dots$  [3]

(f) On the diagram, sketch the graph of  $y = f(x-3)$ . [2]

11

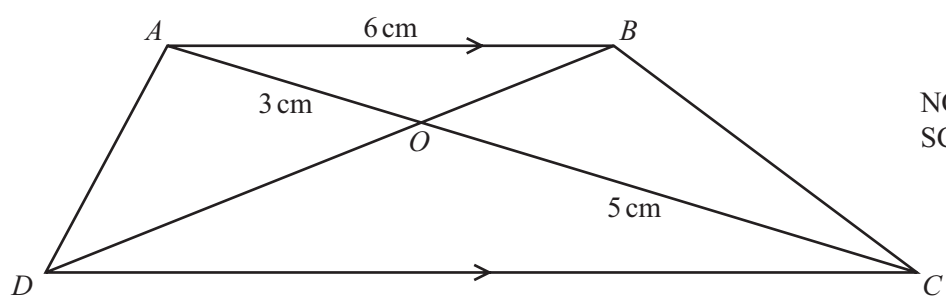

NOT TO  
SCALE

The diagram shows a trapezium  $ABCD$  with diagonals intersecting at  $O$ .  
 $AB$  is parallel to  $DC$ .

(a) Explain why triangle  $AOB$  is similar to triangle  $COD$ .

Answer(a) .....

.....

..... [2]

(b) Calculate the length of  $CD$ .

Answer(b) ..... cm [2]

(c) Find the value of these fractions.

(i)  $\frac{\text{Area of triangle } ABO}{\text{Area of triangle } CBO}$

Answer(c)(i) ..... [1]

(ii)  $\frac{\text{Area of triangle } ABO}{\text{Area of triangle } CDO}$

Answer(c)(ii) ..... [1]

(iii)  $\frac{\text{Area of triangle } ABO}{\text{Area of trapezium } ABCD}$

Answer(c)(iii) ..... [1]

Question 12 is printed on the next page.

12 An aircraft travels 5500 km from Dubai to London.  
The average speed is  $x$  km/h.

(a) Write down an expression, in terms of  $x$ , for the time taken for this journey.

Answer(a) ..... hours [1]

(b) The return journey from London to Dubai is

- 60 km/h faster
- half-an-hour shorter

than the journey from Dubai to London.

Write down an equation in  $x$  and show that it simplifies to  $x^2 + 60x - 660\,000 = 0$ .

[4]

(c) Solve the equation  $x^2 + 60x - 660\,000 = 0$ .  
Give your answers correct to the nearest whole number.

Answer(c)  $x =$  ..... or  $x =$  ..... [3]

(d) The time that the aircraft leaves Dubai is 0940 local time.  
The time in London is 4 hours behind the time in Dubai.

Use your answer to **part (c)** to find the arrival time in London.

Answer(d) ..... [3]

Permission to reproduce items where third-party owned material protected by copyright is included has been sought and cleared where possible. Every reasonable effort has been made by the publisher (UCLES) to trace copyright holders, but if any items requiring clearance have unwittingly been included, the publisher will be pleased to make amends at the earliest possible opportunity.

University of Cambridge International Examinations is part of the Cambridge Assessment Group. Cambridge Assessment is the brand name of University of Cambridge Local Examinations Syndicate (UCLES), which is itself a department of the University of Cambridge.