



Cambridge International Examinations
Cambridge International General Certificate of Secondary Education

CANDIDATE
NAME

CENTER
NUMBER

--	--	--	--	--

CANDIDATE
NUMBER

--	--	--	--



MATHEMATICS (US)

0444/31

Paper 3 (Core)

May/June 2018

2 hours

Candidates answer on the Question Paper.

Additional Materials: Geometrical instruments
 Electronic calculator

READ THESE INSTRUCTIONS FIRST

Write your Center number, candidate number and name on all the work you hand in.

Write in dark blue or black pen.

You may use an HB pencil for any diagrams or graphs.

Do not use staples, paper clips, glue or correction fluid.

DO NOT WRITE IN ANY BARCODES.

Answer **all** questions.

If work is needed for any question it must be shown in the space provided.

Electronic calculators should be used.

If the degree of accuracy is not specified in the question, and if the answer is not exact, give the answer to three significant digits.

Give answers in degrees to one decimal place.

For π , use either your calculator value or 3.142.

The number of points is given in parentheses [] at the end of each question or part question.

The total of the points for this paper is 104.

Write your calculator model in the box below.

This document consists of **20** printed pages.

Formula List

Area, A , of triangle, base b , height h .

$$A = \frac{1}{2}bh$$

Area, A , of circle, radius r .

$$A = \pi r^2$$

Circumference, C , of circle, radius r .

$$C = 2\pi r$$

Lateral surface area, A , of cylinder of radius r , height h .

$$A = 2\pi r h$$

Surface area, A , of sphere of radius r .

$$A = 4\pi r^2$$

Volume, V , of prism, cross-sectional area A , length l .

$$V = Al$$

Volume, V , of cylinder of radius r , height h .

$$V = \pi r^2 h$$

Volume, V , of sphere of radius r .

$$V = \frac{4}{3}\pi r^3$$

1 (a) Write down

(i) the number twenty-seven million, three hundred sixty thousand, forty-five in figures,

..... [1]

(ii) the six factors of 20,

.....,,,,, [2]

(iii) a fraction that is equivalent to $\frac{7}{9}$,

..... [1]

(iv) a prime number between 30 and 40.

..... [1]

(b) For each statement, insert one pair of parentheses to make it correct.

(i) $17 - 3 \times 5 - 3 = 11$ [1]

(ii) $3 + 2^2 - 4 = 21$ [1]

(c) Find $\sqrt[3]{4913}$.

..... [1]

2 Mr Marr asks his mathematics class to complete a statistics project about books.

(a) Olga counts the number of letters in each of the last 20 words in the book she is reading. Here are her results.

1	2	2	2	2
3	3	3	3	4
4	4	5	5	5
5	5	6	6	8

(i) Find the range.

..... [1]

(ii) Find the median.

..... [1]

(iii) Complete the frequency table.

Number of letters in each word	Frequency
1	
2	
3	
4	3
5	
6	
7	
8	

[1]

(iv) Complete the diagram to show a dot plot.

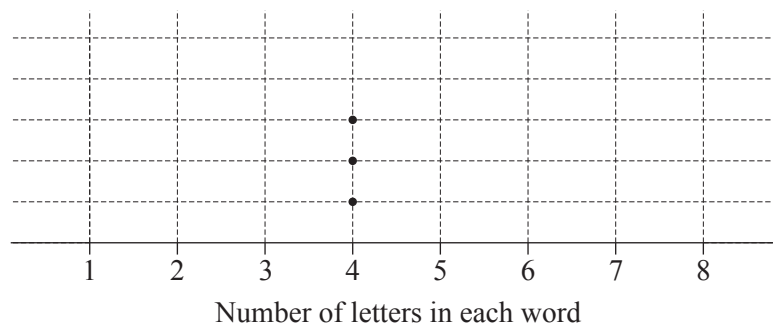

[1]

- (b) Billie asks 60 students in his school what their favorite type of book is. He has started to draw a table of his results. The remaining students chose romance.

Type of book	Tally	Frequency
Comedy		16
Science Fiction		10
Poetry		
Music		
Romance		
Crime		20

- (i) Complete the table. [2]

- (ii) Work out how many more students chose crime books than music books.

..... [1]

- (iii) Work out the fraction of students who chose comedy or science fiction books.

..... [2]

- (iv) Work out the percentage of students who did **not** choose poetry books.

.....% [2]

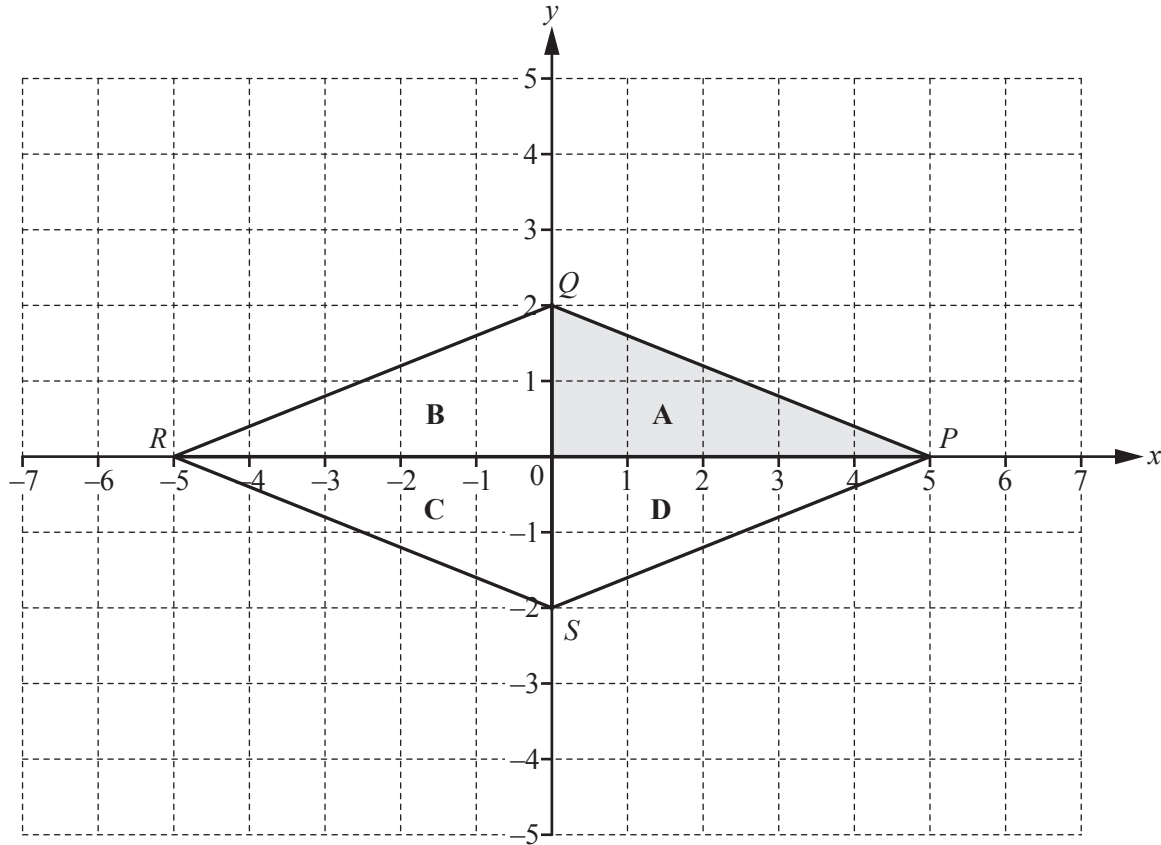

The diagram shows a quadrilateral $PQRS$ that is made from four congruent triangles **A**, **B**, **C**, and **D**.

(a) Write down the mathematical name for the quadrilateral $PQRS$.

..... [1]

(b) (i) Write down the co-ordinates of S .

(..... ,) [1]

(ii) Measure the obtuse angle PSR .

..... [1]

(c) (i) Measure the length of the line PQ .

..... cm [1]

(ii) Work out the perimeter of the quadrilateral $PQRS$.

..... cm [1]

(d) Describe fully the **single** transformation that maps

(i) triangle **A** onto triangle **B**,

.....
..... [2]

(ii) triangle **A** onto triangle **C**.

.....
..... [3]

(e) On the grid, draw the image of triangle **D** after a translation by the vector $\begin{pmatrix} 1 \\ -2 \end{pmatrix}$. [2]

- 4 Lucy asked 12 people how many hours they each spent playing a computer game and the number of levels they each completed in one month.

The results are shown in the table.

Time spent playing (hours)	90	32	70	75	30	70	40	80	40	65	50	32
Number of levels completed	22	5	12	17	6	7	18	20	8	15	11	9

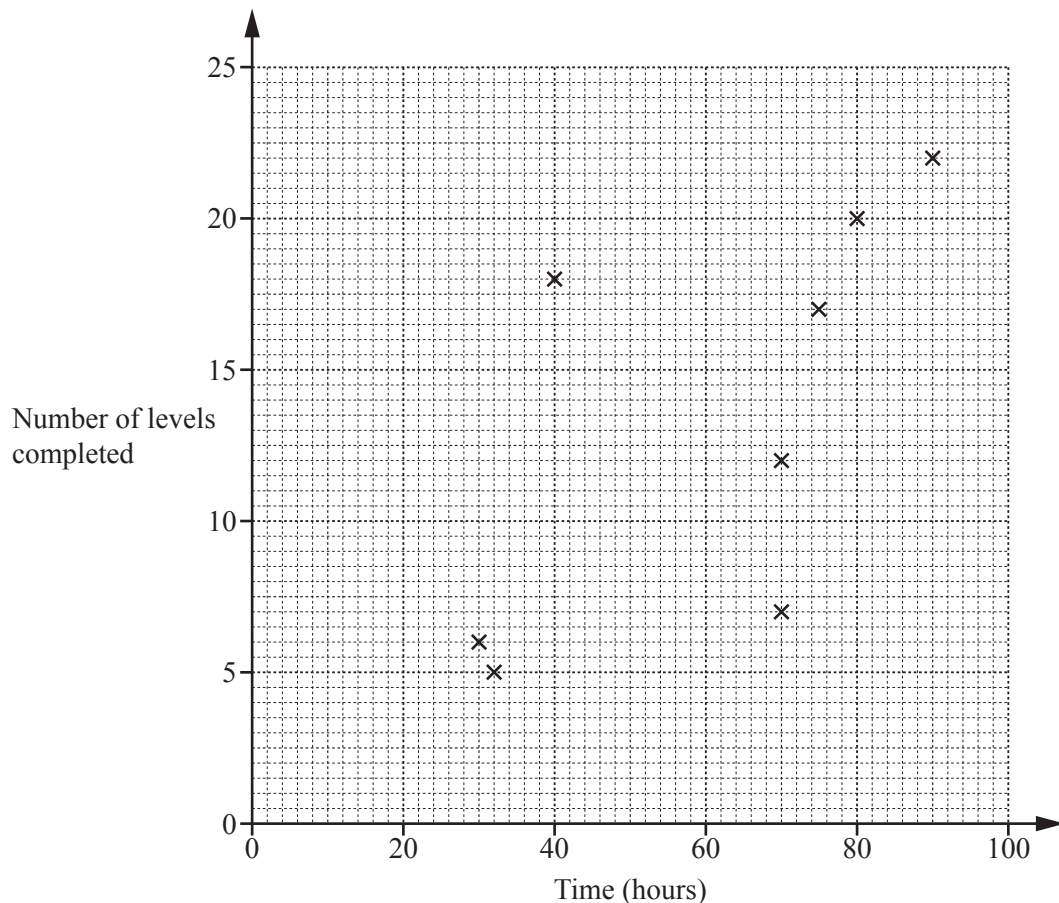

- (a) Complete the scatter diagram.
The first eight points have been plotted for you. [2]
- (b) One person completes more levels per hour than any of the others.
On the scatter diagram, put a ring around the point for this person. [1]
- (c) What type of correlation does this scatter diagram show?

..... [1]

(d) On the scatter diagram, draw a line of best fit. [1]

(e) Another person, Monika, completed 19 levels but forgot to record the time spent playing.

Use your line of best fit to estimate the number of hours that Monika spent playing.

..... hours [1]

5 Georgiana is traveling by train from Redtown to Teignley.

- (a) The price of a ticket is \$13.50 .
Georgiana's ticket price is reduced by one-third because she is a student.

Work out how much she pays for her ticket.

\$ [2]

- (b) Georgiana travels on two trains.
The first train goes from Redtown to Southford.
The second train goes from Southford to Teignley.
She has written down some information about the times of her trains.

<u>First train</u>		
Redtown	departs	13 45
Southford	arrives	16 39
<u>Second train</u>		
Southford	departs	17 12

- (i) Write 13 45 using the 12-hour clock.

..... [1]

- (ii) Work out how long the first train should take to travel from Redtown to Southford.
Give your answer in hours and minutes.

..... h min [1]

- (iii) The first train arrives at Southford 46 minutes late.

By how many minutes has Georgiana missed her second train?

..... min [2]

- (c) While Georgiana waits for the next train, she buys a cup of hot chocolate.

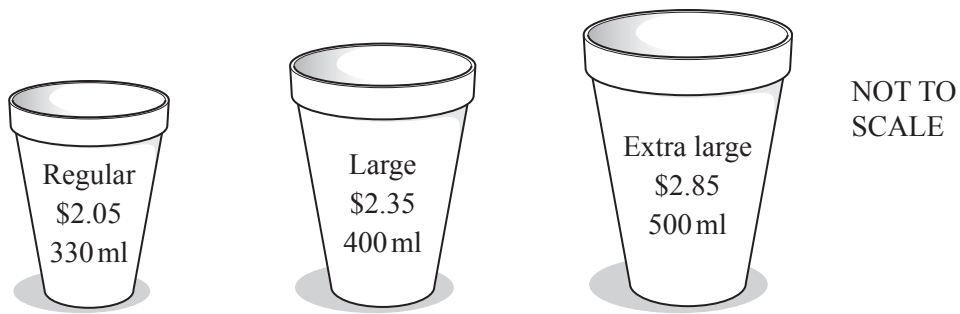

Work out which cup of hot chocolate is the best value.
Show all your working.

..... [3]

- (d) The next train from Southford to Teignley is at 18 12.
The journey is 76 km and the train travels at an average speed of 48 km/h.

Work out the time that the train arrives in Teignley.

..... [3]

- 6 (a) The scale drawing shows the positions of Annika's house, *A*, and Bernhard's house, *B*, on a map. The scale is 1 centimeter represents 300 meters.

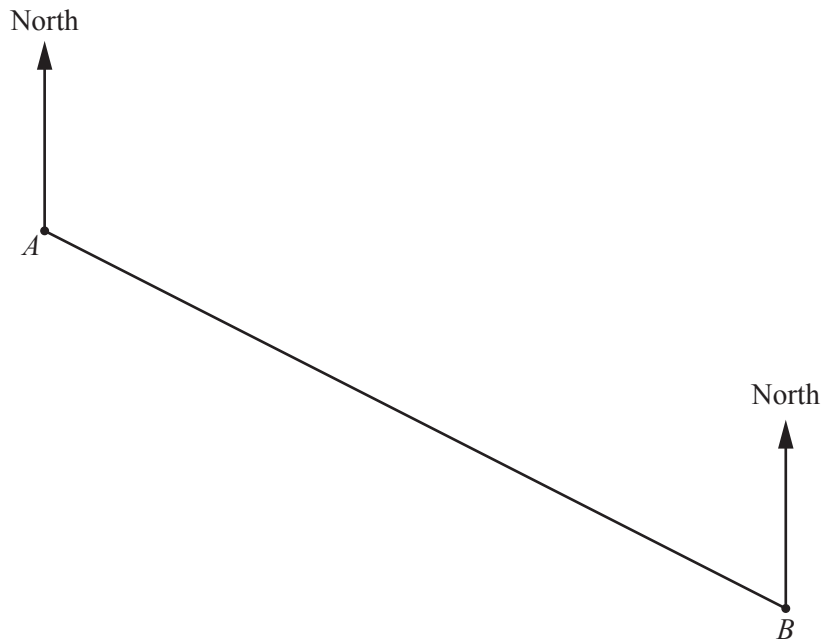

Scale: 1 cm to 300 m

- (i) Work out the actual distance, in meters, between Annika's house and Bernhard's house.

..... m [2]

- (ii) Measure the bearing of Bernhard's house from Annika's house.

..... [1]

- (iii) Cordelia's house is 1650 meters from Bernhard's house on a bearing of 320° .

Mark on the map the position of Cordelia's house.
Label this point *C*.

[2]

(b) This scale drawing shows the positions of a store (S), restaurant (R), and gas station (G).

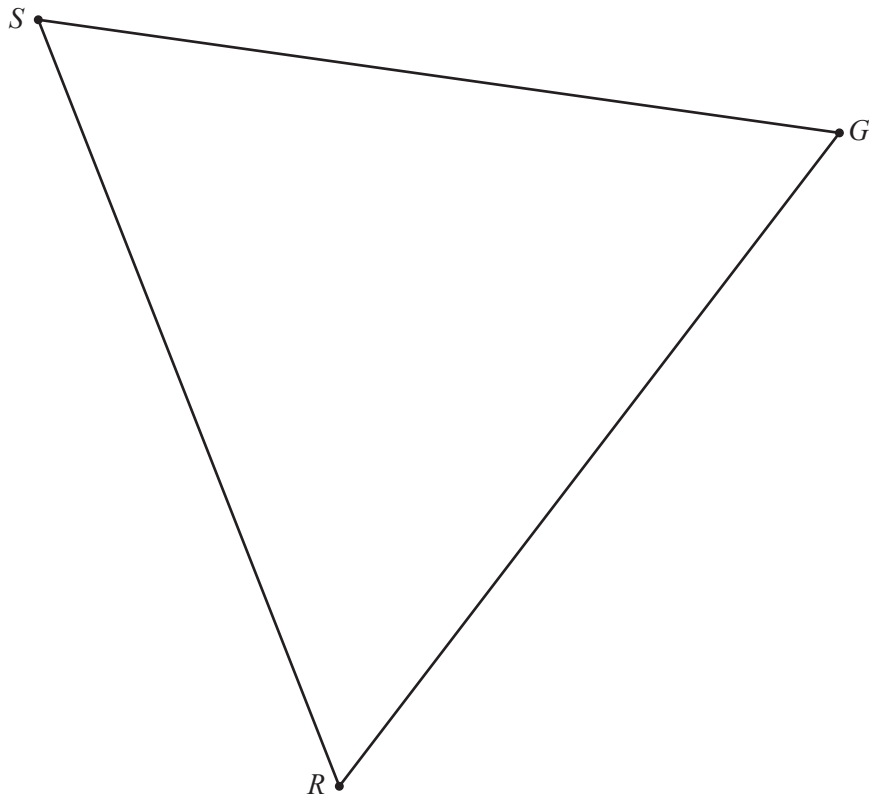

There is an intersection at the point where the perpendicular bisector of GR and the bisector of angle SRG meet.

Using a straight edge and compass only and showing all your construction arcs, construct the position of the intersection.

[4]

- 7 (a) The diagram shows a flower vase.

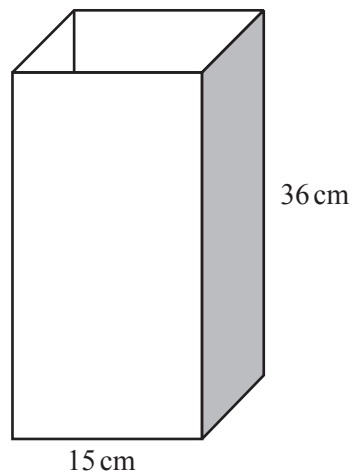

NOT TO
SCALE

The base of the vase is a square.
The vase is filled with water to a depth of 20 cm.

- (i) Calculate the volume of water in the vase.

..... cm³ [2]

- (ii) Packets of flower food are to be mixed with the water in the vase.
One packet of food should be added to each 500 cm³ of water.

How many packets of flower food should be added to the water in the vase?

..... [2]

(b) Here is another flower vase.

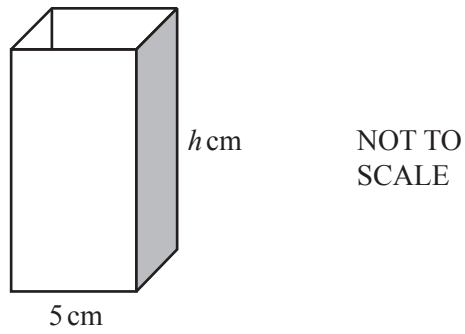

This vase is mathematically similar to the vase in **part (a)**.

(i) Find the value of h .

$$h = \dots\dots\dots [2]$$

(ii) The smaller vase contains 150 cm^3 of water.

Calculate the depth of the water in this vase.

$$\dots\dots\dots \text{ cm} [2]$$

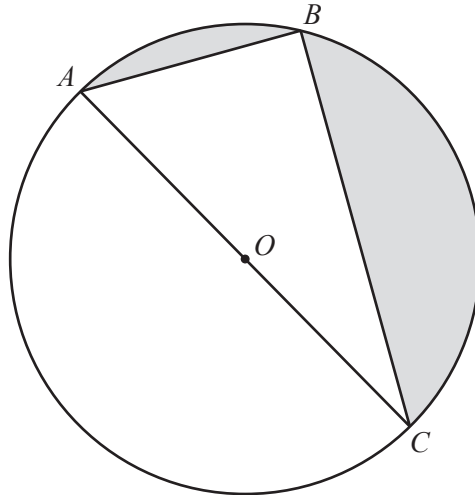

NOT TO
SCALE

A , B , and C are points on the circumference of a circle, center O .

(a) Write down the mathematical name for

(i) the straight line AC ,

..... [1]

(ii) the straight line AB .

..... [1]

(b) Give a geometrical reason why angle $ABC = 90^\circ$.

..... [1]

(c) $AB = 20$ cm and $AC = 52$ cm.

(i) Use trigonometry to calculate angle BAC .

Angle $BAC = \dots\dots\dots$ [2]

(ii) Show that $BC = 48$ cm.

[2]

(iii) Work out the area of triangle ABC .

$\dots\dots\dots$ cm^2 [2]

(iv) Work out the total shaded area.

$\dots\dots\dots$ cm^2 [3]

9 (a) (i) Write down the slope of the line $y = -4x + 7$.

..... [1]

(ii) Write down the equation of a line parallel to $y = 2x + 3$.

$y =$ [1]

(iii) Write down the co-ordinates of the point where the graph of $y = 6x - 5$ crosses the y -axis.

(..... ,) [1]

(iv) The point $(k, 7)$ lies on the line $y = 4x - 3$.

Find the value of k .

$k =$ [2]

(b) (i) Complete the table of values for $y = x^2 - x - 5$.

x	-3	-2	-1	0	1	2	3	4
y	7		-3		-5			

[3]

- (ii) On the grid, draw the graph of $y = x^2 - x - 5$ for $-3 \leq x \leq 4$.

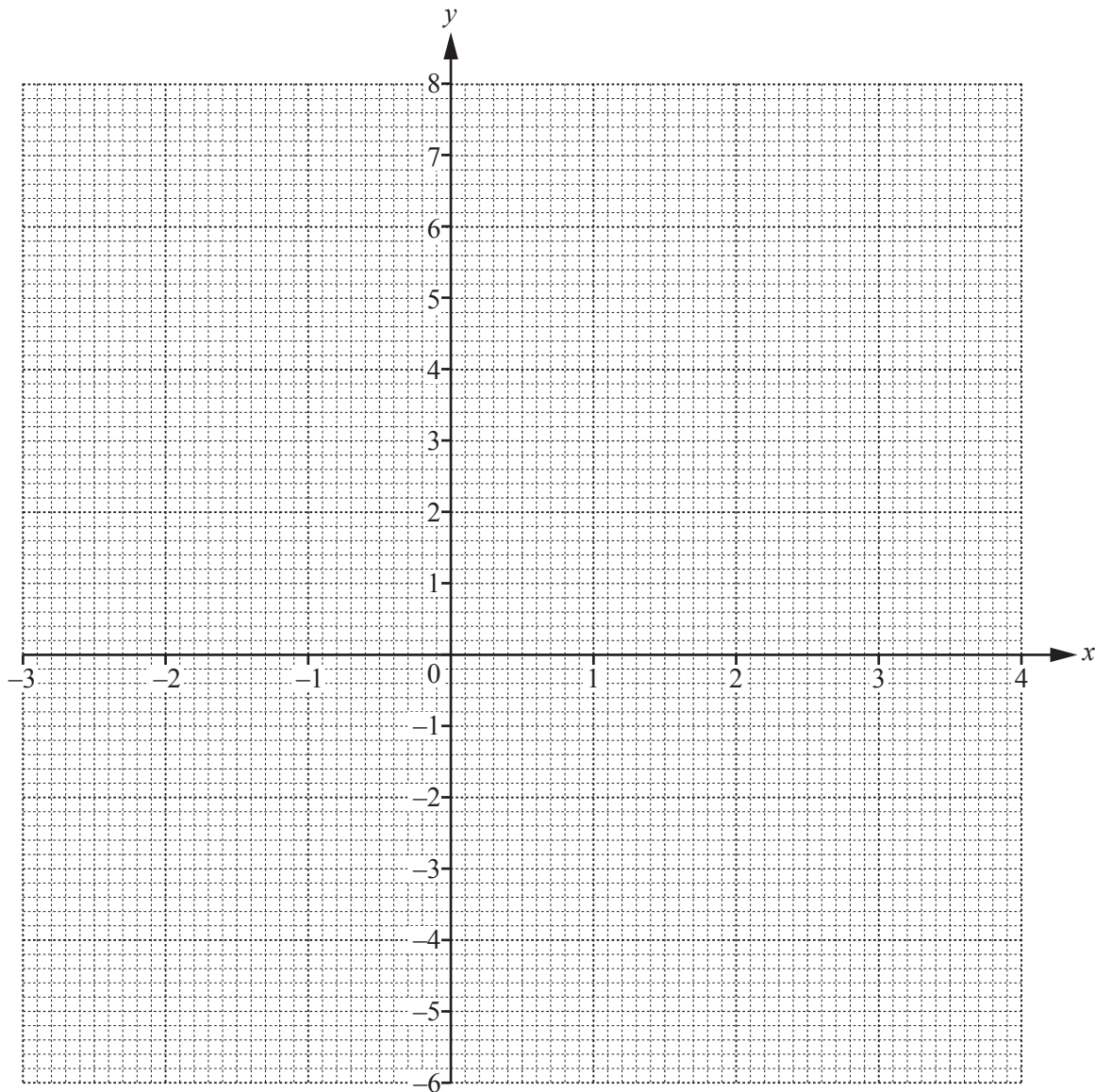

[4]

- (iii) Write down the co-ordinates of the lowest point on the graph.

(..... ,) [1]

- (iv) (a) On the grid, draw the line of symmetry of the graph. [1]

- (b) Write down the equation of this line.

..... [1]

Question 10 is printed on the next page.

10 Three boys each have \$600.

(a) Victor spends 40% of his \$600.

He spends the money in the ratio clothes : books : music = 10 : 2 : 3.

(i) Work out how much he spends on music.

\$ [3]

(ii) Work out how much more he spends on clothes than books.

\$ [2]

(b) Walter invests his \$600 for 3 years at a rate of 4.5% per year compound interest.

Calculate the interest Walter receives at the end of the 3 years.

\$ [3]

(c) Xavier goes on vacation to Europe and changes his \$600 into euros (€).

He spends €325 while he is on vacation.

When he gets home, he changes the euros he has left back into dollars.

The exchange rate is $\$1 = \text{€}0.864$.

Work out how many dollars he has left after his vacation.

Give your answer correct to the nearest cent.

\$ [3]

Permission to reproduce items where third-party owned material protected by copyright is included has been sought and cleared where possible. Every reasonable effort has been made by the publisher (UCLES) to trace copyright holders, but if any items requiring clearance have unwittingly been included, the publisher will be pleased to make amends at the earliest possible opportunity.

To avoid the issue of disclosure of answer-related information to candidates, all copyright acknowledgements are reproduced online in the Cambridge International Examinations Copyright Acknowledgements Booklet. This is produced for each series of examinations and is freely available to download at www.cie.org.uk after the live examination series.

Cambridge International Examinations is part of the Cambridge Assessment Group. Cambridge Assessment is the brand name of University of Cambridge Local Examinations Syndicate (UCLES), which is itself a department of the University of Cambridge.