

Cambridge IGCSE™

CANDIDATE
NAME

CENTRE
NUMBER

--	--	--	--	--

CANDIDATE
NUMBER

--	--	--	--

MATHEMATICS

0580/12

Paper 1 (Core)

October/November 2020

1 hour

You must answer on the question paper.

You will need: Geometrical instruments

INSTRUCTIONS

- Answer **all** questions.
- Use a black or dark blue pen. You may use an HB pencil for any diagrams or graphs.
- Write your name, centre number and candidate number in the boxes at the top of the page.
- Write your answer to each question in the space provided.
- Do **not** use an erasable pen or correction fluid.
- Do **not** write on any bar codes.
- You should use a calculator where appropriate.
- You may use tracing paper.
- You must show all necessary working clearly.
- Give non-exact numerical answers correct to 3 significant figures, or 1 decimal place for angles in degrees, unless a different level of accuracy is specified in the question.
- For π , use either your calculator value or 3.142.

INFORMATION

- The total mark for this paper is 56.
- The number of marks for each question or part question is shown in brackets [].

This document has **12** pages. Blank pages are indicated.



1 Write two hundred thousand and seventeen in figures.

..... [1]

2 Write 867 correct to the nearest ten.

..... [1]

3

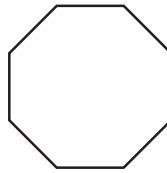

Write down the order of rotational symmetry of this regular octagon.

..... [1]

4 A bag contains 20 balls.
5 of these balls are red.
A ball is picked at random from the bag.

On the probability scale, draw an arrow (↓) to show the probability that this ball is red.

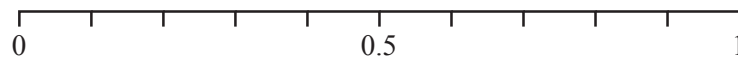

[1]

5 Work out the number of hours in 3 days.

..... hours [1]

6 Write these in order of size, starting with the smallest.

$$\frac{11}{27} \quad 41\% \quad 0.4 \quad \frac{16}{39}$$

..... < < < [2]
smallest

7 Solve the equation.

$$6 - 2x = 3x$$

$$x = \dots\dots\dots [2]$$

8 Work out the difference in temperature between -6°C and 5°C .

$$\dots\dots\dots^{\circ}\text{C} [1]$$

9 $A = \frac{1}{4}bc^2$

Calculate the value of A when $b = 3$ and $c = 6$.

$$\dots\dots\dots [2]$$

10

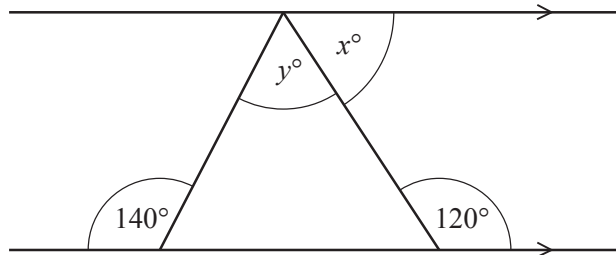

NOT TO
SCALE

The diagram shows a triangle drawn between a pair of parallel lines.

Find the value of x and the value of y .

$$x = \dots\dots\dots$$

$$y = \dots\dots\dots [3]$$

11

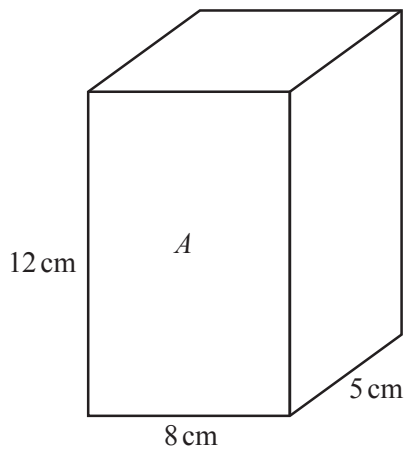
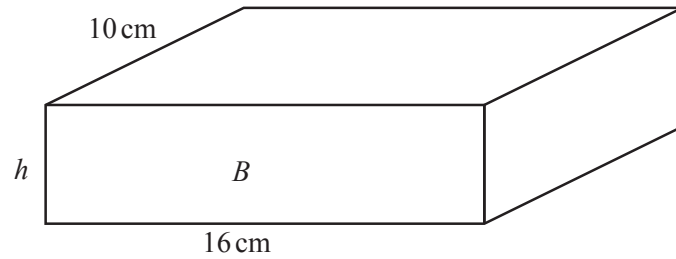
NOT TO
SCALE

The diagram shows cuboid *A* and cuboid *B*.
Cuboid *A* has the same volume as cuboid *B*.

Calculate the height, *h*, of cuboid *B*.

$$h = \dots\dots\dots \text{ cm [3]}$$

12 Fernando records the favourite sport of each of 20 people.

football	cricket	rugby	cricket	rugby	rugby	football	football	rugby	football
cricket	rugby	tennis	football	tennis	football	rugby	cricket	football	cricket

(a) Complete the frequency table to show this information.

You may use the tally column to help you.

Favourite sport	Tally	Frequency
Cricket		
Football		
Rugby		
Tennis		

[2]

(b) Fernando wants to draw a pie chart to show this information.

Work out the sector angle for football.

..... [2]

13 Increase 42 by 16%.

..... [2]

14 These are the first four terms of a sequence.

17 10 3 -4

(a) (i) Find the next term.

..... [1]

(ii) Write down the term to term rule for continuing this sequence.

..... [1]

(b) These are the first four terms of a different sequence.

-2 2 6 10

Find an expression for the n th term.

..... [2]

15

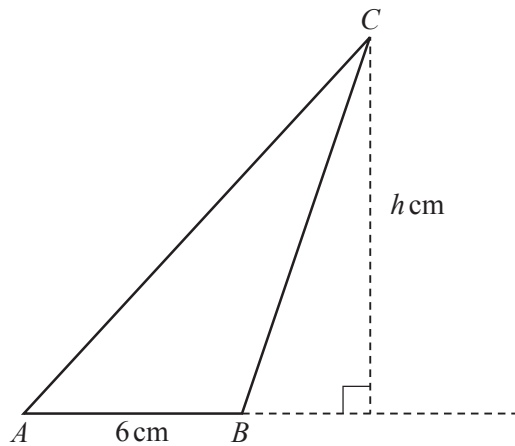

NOT TO
SCALE

The area of triangle ABC is 27 cm^2 and $AB = 6 \text{ cm}$.

Calculate the value of h .

$h =$ [2]

16 (a)

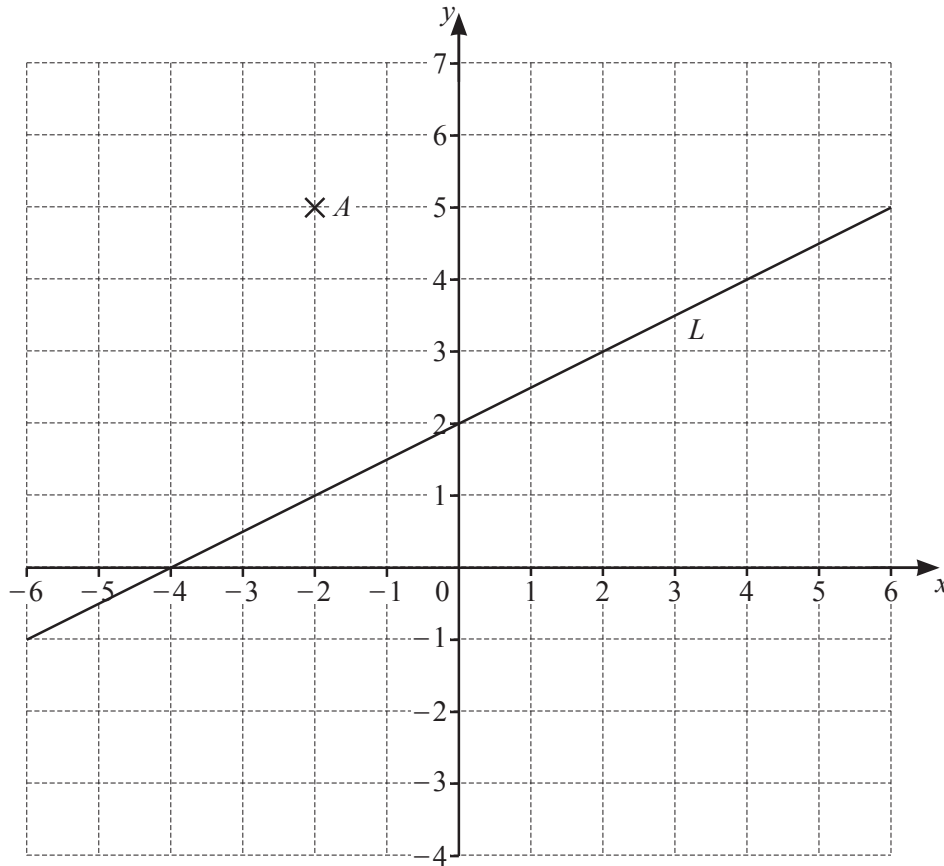

(i) Write down the coordinates of point A .

(..... ,) [1]

(ii) On the grid, plot the point $(2, -3)$.

[1]

(iii) The line L is shown on the grid.

Find the equation of the line L in the form $y = mx + c$.

$y = \dots\dots\dots$ [2]

(b) Write down the equation of the line parallel to $y = 5x + 6$ that passes through $(0, -7)$.

$y = \dots\dots\dots$ [1]

17 **Without using a calculator**, work out $\frac{5}{6} \div 1\frac{1}{3}$.

You must show all your working and give your answer as a fraction in its simplest form.

..... [3]

18 (a) The length, l cm, of a pencil is 18 cm, correct to the nearest centimetre.

Complete the statement about the value of l .

..... $\leq l <$ [2]

(b) (i) Write 9.314×10^5 as an ordinary number.

..... [1]

(ii) Calculate $(4.1 \times 10^{-3}) \times (8.9 \times 10^7)$.
Give your answer in standard form.

..... [2]

(c) Calculate $\sqrt{(8 + 4 \times 75^{0.6})}$.

..... [1]

- 19 The length of one side of a rectangle is 12 cm.
The length of the diagonal of the rectangle is 13 cm.

Calculate the area of the rectangle.

..... cm² [3]

- 20 Alex and Chris share sweets in the ratio Alex : Chris = 7 : 3.
Alex receives 20 more sweets than Chris.

Work out the number of sweets Chris receives.

..... [2]

10

21 Write 825 as the product of its prime factors.

..... [2]

22

NOT TO
SCALE

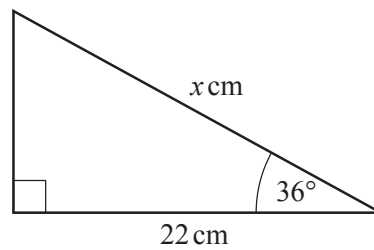

Show that the value of x is 27.2, correct to 3 significant figures.

[3]

23

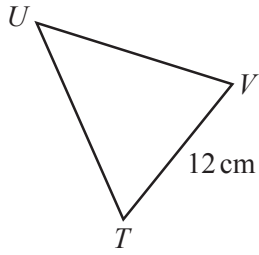

11

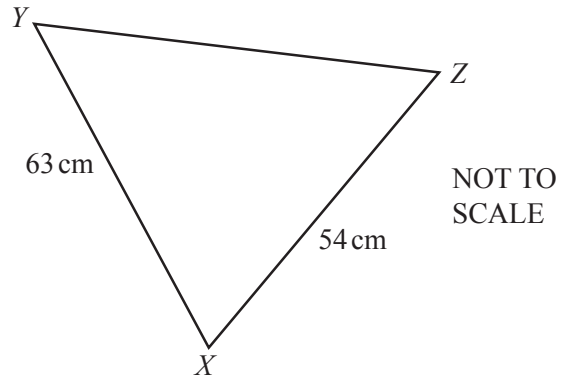

The diagram shows two similar triangles TUV and XYZ .

Calculate UT .

$UT = \dots\dots\dots\text{ cm}$ [2]

BLANK PAGE

Permission to reproduce items where third-party owned material protected by copyright is included has been sought and cleared where possible. Every reasonable effort has been made by the publisher (UCLES) to trace copyright holders, but if any items requiring clearance have unwittingly been included, the publisher will be pleased to make amends at the earliest possible opportunity.

To avoid the issue of disclosure of answer-related information to candidates, all copyright acknowledgements are reproduced online in the Cambridge Assessment International Education Copyright Acknowledgements Booklet. This is produced for each series of examinations and is freely available to download at www.cambridgeinternational.org after the live examination series.

Cambridge Assessment International Education is part of the Cambridge Assessment Group. Cambridge Assessment is the brand name of the University of Cambridge Local Examinations Syndicate (UCLES), which itself is a department of the University of Cambridge.