



Cambridge IGCSE™

CANDIDATE
NAME

CENTRE
NUMBER

--	--	--	--	--

CANDIDATE
NUMBER

--	--	--	--

MATHEMATICS

0580/12

Paper 1 (Core)

February/March 2021

1 hour

You must answer on the question paper.

You will need: Geometrical instruments

INSTRUCTIONS

- Answer **all** questions.
- Use a black or dark blue pen. You may use an HB pencil for any diagrams or graphs.
- Write your name, centre number and candidate number in the boxes at the top of the page.
- Write your answer to each question in the space provided.
- Do **not** use an erasable pen or correction fluid.
- Do **not** write on any bar codes.
- You should use a calculator where appropriate.
- You may use tracing paper.
- You must show all necessary working clearly.
- Give non-exact numerical answers correct to 3 significant figures, or 1 decimal place for angles in degrees, unless a different level of accuracy is specified in the question.
- For π , use either your calculator value or 3.142.

INFORMATION

- The total mark for this paper is 56.
- The number of marks for each question or part question is shown in brackets [].

This document has **12** pages. Any blank pages are indicated.



1

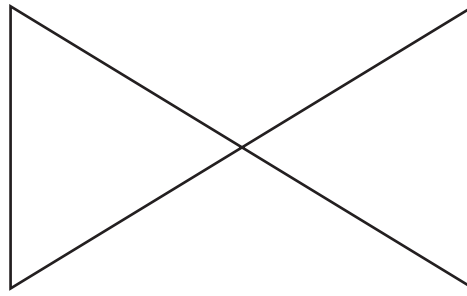

(a) Complete this statement.

The diagram has rotational symmetry of order [1]

(b) On the diagram, draw all the lines of symmetry. [2]

2 (a) On the grid, draw a kite.

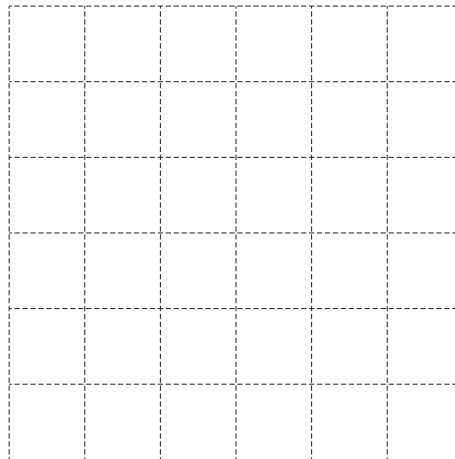

[1]

(b) Write down two geometrical properties of a rhombus.

1.

2. [2]

3 Calculate the value of $\sqrt{7.29}$.

..... [1]

4 Write down a multiple of 9 between 100 and 110.

..... [1]

5 (a) Tanvi rounds the number 4896.
She writes down 4900.
Rahul says Tanvi rounded 4896 correct to the nearest 100.

Explain why Rahul cannot be certain that Tanvi rounded 4896 correct to the nearest 100.

.....
..... [1]

(b) Calculate.

$$\frac{6.4 \times 4^2}{17.9 - 6.1}$$

Give your answer correct to 3 decimal places.

..... [2]

6 These are the heights of four sisters.

1.61 m 1.65 m 1.53 m 1.58 m

(a) Work out the range of these heights.
Give your answer in centimetres.

..... cm [2]

(b) The four sisters have a brother.
The range of the five heights is 18 cm.

Work out the two possible heights of the brother.

..... m or m [2]

7 Work out.

(a) $2\begin{pmatrix} -3 \\ 7 \end{pmatrix}$

$$\begin{pmatrix} \\ \end{pmatrix} [1]$$

(b) $\begin{pmatrix} 8 \\ -6 \end{pmatrix} + \begin{pmatrix} -5 \\ 2 \end{pmatrix}$

$$\begin{pmatrix} \\ \end{pmatrix} [1]$$

8 Sahil and Anika share \$78 in the ratio 5 : 8.

Calculate the amount each receives.

Sahil \$

Anika \$ [2]

5

9

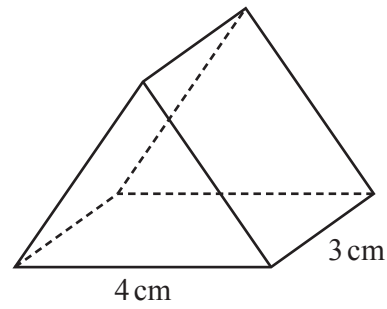
NOT TO
SCALE

The diagram shows a prism.
The cross-section of the prism is an equilateral triangle.

Draw a net of the prism on the 1cm^2 grid.

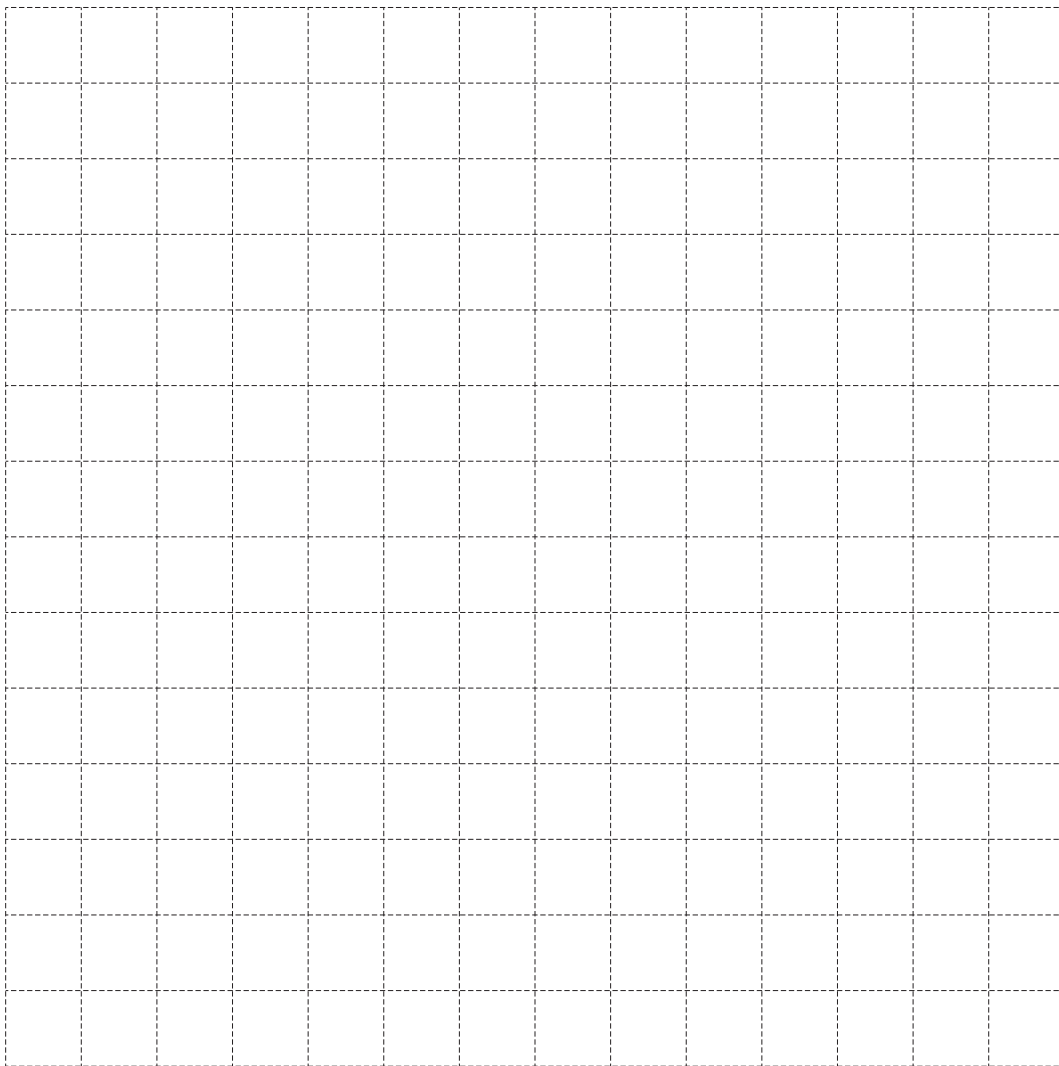

[3]

- 10 The number of passengers on a bus is recorded each day for 14 days.

15	18	22	17	35	38	24
19	19	24	25	31	36	29

Complete the stem-and-leaf diagram.

1	
2	
3	

Key: 1|5 represents 15 passengers

[2]

- 11 The mean of nine numbers is 17.
Seven of these numbers add to 132.
The other two numbers have a difference of 5.

Find the two numbers with a difference of 5.

....., [3]

- 12 Factorise completely.

$$9t^2w - 3t$$

..... [2]

- 13 Saanvi makes some biscuits.
She sells $\frac{5}{13}$ of the biscuits.
She now has 96 biscuits left.

Work out the total number of biscuits Saanvi makes.

..... [3]

- 14 These are the first four terms of a sequence.

29 22 15 8

- (a) Write down the next two terms.

..... , [2]

- (b) Find the n th term.

..... [2]

- 15 Find the lowest common multiple (LCM) of 18 and 21.

..... [2]

16 (a) Write 567 000 000 in standard form.

..... [1]

(b) 6.5×10^{-2} 6.1×10^{-1} 6.2×10^2 6.79×10^1 6.18×10^2 6.35×10^{-2}

Calculate the product of the largest number and the smallest number from this list.
Give your answer in standard form.

..... [2]

17

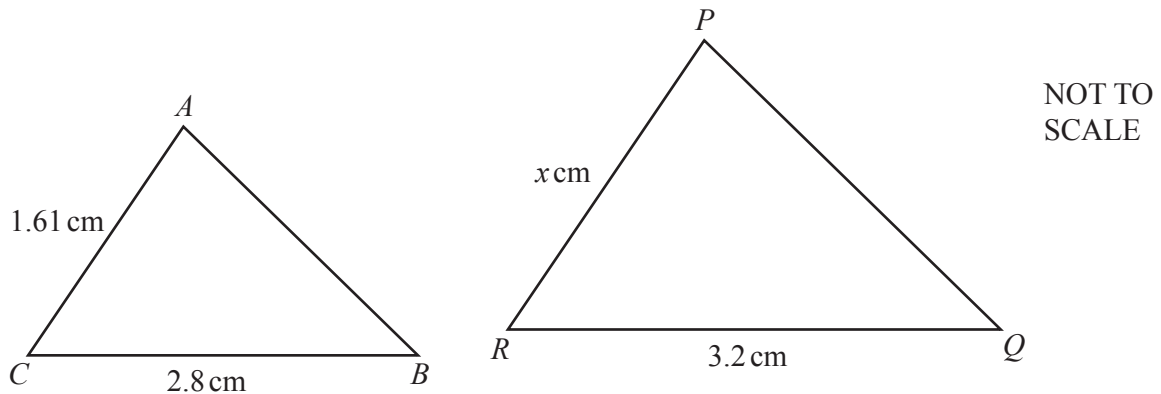

Triangle ABC is mathematically similar to triangle PQR .

Find the value of x .

$x =$ [2]

18 (a) Simplify.

(i) $x^{12} \div x^3$

..... [1]

(ii) $(y^2)^5$

..... [1]

(b) $3^p = \frac{1}{81}$

Find the value of p .

$p =$ [1]

19 Without using a calculator, work out $2\frac{1}{4} \times 3\frac{2}{3}$.

You must show all your working and give your answer as a mixed number in its simplest form.

..... [3]

10

- 20 Solve the simultaneous equations.
You must show all your working.

$$5x + 6y = 14$$

$$2x + 8y = 7$$

$x = \dots\dots\dots$

$y = \dots\dots\dots [4]$

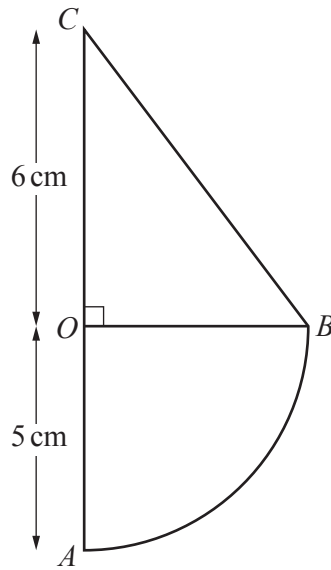

NOT TO
SCALE

The diagram shows a shape made from a quarter-circle, OAB , and a right-angled triangle OBC . The radius of the circle is 5 cm and $OC = 6$ cm.

Calculate the area of the shape.

..... cm^2 [3]

BLANK PAGE

Permission to reproduce items where third-party owned material protected by copyright is included has been sought and cleared where possible. Every reasonable effort has been made by the publisher (UCLES) to trace copyright holders, but if any items requiring clearance have unwittingly been included, the publisher will be pleased to make amends at the earliest possible opportunity.

To avoid the issue of disclosure of answer-related information to candidates, all copyright acknowledgements are reproduced online in the Cambridge Assessment International Education Copyright Acknowledgements Booklet. This is produced for each series of examinations and is freely available to download at www.cambridgeinternational.org after the live examination series.

Cambridge Assessment International Education is part of the Cambridge Assessment Group. Cambridge Assessment is the brand name of the University of Cambridge Local Examinations Syndicate (UCLES), which itself is a department of the University of Cambridge.