



Cambridge International Examinations
Cambridge International General Certificate of Secondary Education

CANDIDATE
NAME

CENTRE
NUMBER

--	--	--	--	--

CANDIDATE
NUMBER

--	--	--	--

CAMBRIDGE INTERNATIONAL MATHEMATICS

0607/32

Paper 3 (Core)

October/November 2016

1 hour 45 minutes

Candidates answer on the Question Paper.

Additional Materials: Geometrical Instruments
 Graphics Calculator

READ THESE INSTRUCTIONS FIRST

Write your Centre number, candidate number and name on all the work you hand in.

Write in dark blue or black pen.

Do not use staples, paper clips, glue or correction fluid.

You may use an HB pencil for any diagrams or graphs.

DO NOT WRITE IN ANY BARCODES.

Answer **all** the questions.

Unless instructed otherwise, give your answers exactly or correct to three significant figures as appropriate.

Answers in degrees should be given to one decimal place.

For π , use your calculator value.

You must show all the relevant working to gain full marks and you will be given marks for correct methods, including sketches, even if your answer is incorrect.

The number of marks is given in brackets [] at the end of each question or part question.

The total number of marks for this paper is 96.

This document consists of **19** printed pages and **1** blank page.

Formula List

Area, A , of triangle, base b , height h .

$$A = \frac{1}{2}bh$$

Area, A , of circle, radius r .

$$A = \pi r^2$$

Circumference, C , of circle, radius r .

$$C = 2\pi r$$

Curved surface area, A , of cylinder of radius r , height h .

$$A = 2\pi r h$$

Curved surface area, A , of cone of radius r , sloping edge l .

$$A = \pi r l$$

Curved surface area, A , of sphere of radius r .

$$A = 4\pi r^2$$

Volume, V , of prism, cross-sectional area A , length l .

$$V = Al$$

Volume, V , of pyramid, base area A , height h .

$$V = \frac{1}{3}Ah$$

Volume, V , of cylinder of radius r , height h .

$$V = \pi r^2 h$$

Volume, V , of cone of radius r , height h .

$$V = \frac{1}{3}\pi r^2 h$$

Volume, V , of sphere of radius r .

$$V = \frac{4}{3}\pi r^3$$

Answer **all** the questions.

1 (a) Here is a child's drawing of a house and the path leading to the door.

Complete each label with the mathematical name of the shaded shape.

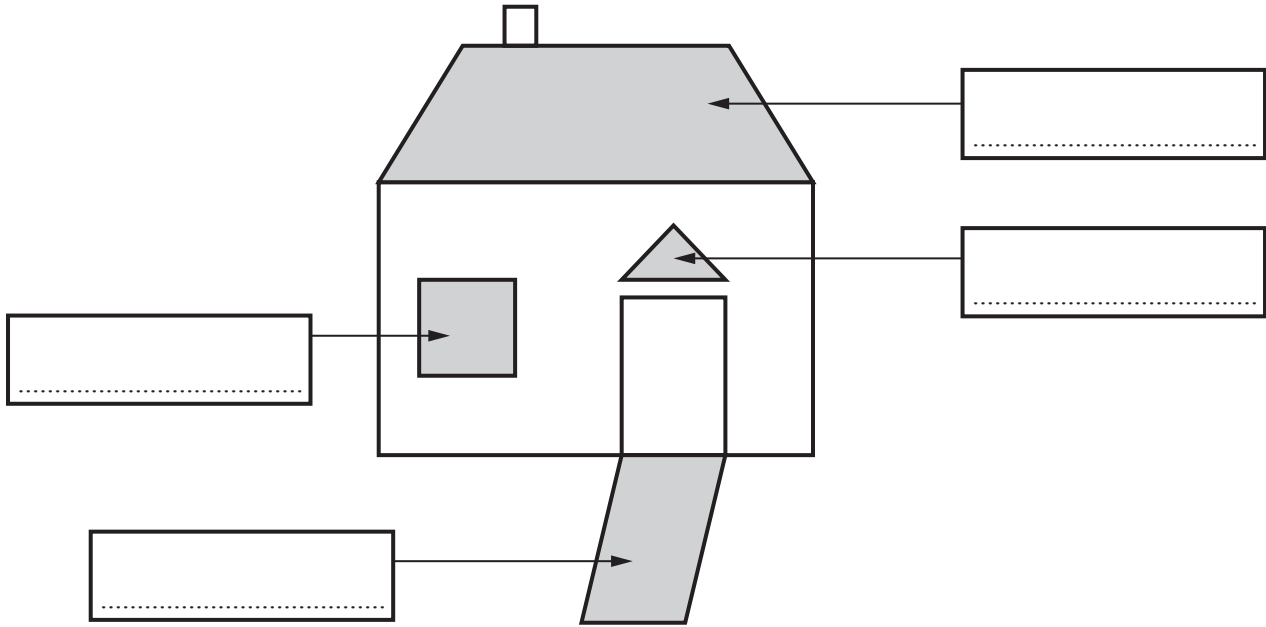

[4]

(b) Here is a rectangle.

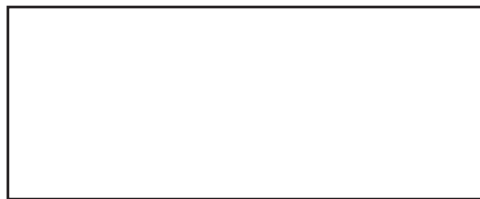

(i) Write down the order of rotational symmetry of the rectangle.

..... [1]

(ii) On the rectangle, draw all the lines of symmetry.

[2]

2 175 students, aged 14, 15 or 16, are going on a school trip.

(a) The bar chart below shows the number of males (M) and females (F) in each age group.

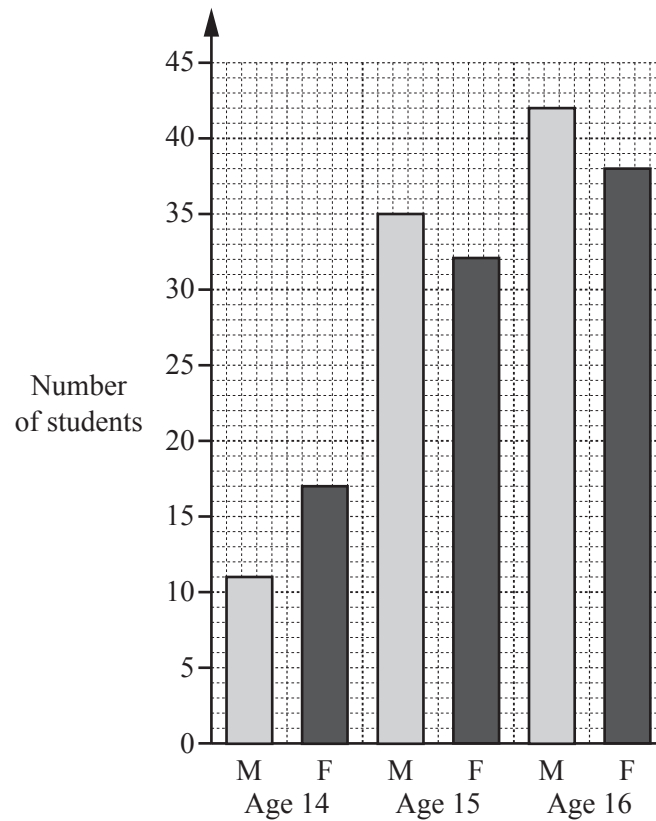

(i) Find the number of females aged 16.

..... [1]

(ii) Of the students aged 14, find how many more females than males there are.

..... [1]

(iii) Find the total number of students aged 15.

..... [2]

- (b) The trip costs each student \$25.

Work out the total amount the 175 students pay.
Give your answer correct to the nearest hundred dollars.

\$ [2]

- (c) 12 teachers, together with the 175 students all travel by coach.
Each coach holds 44 passengers.

Work out how many coaches will be needed.

..... [3]

3 (a) (i) Measure the size of angle p .

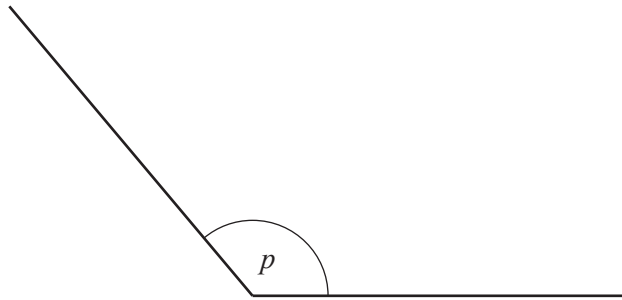

Angle $p = \dots\dots\dots$ [1]

(ii) What type of angle is angle p ?

Choose from the list below.

- | | | | |
|-------|--------|--------|-------------|
| acute | obtuse | reflex | right-angle |
|-------|--------|--------|-------------|

$\dots\dots\dots$ [1]

(b)

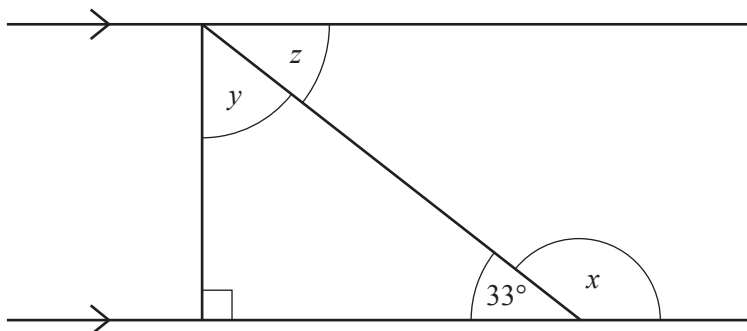

NOT TO SCALE

Find the size of angle x , angle y and angle z .

Angle $x = \dots\dots\dots$

Angle $y = \dots\dots\dots$

Angle $z = \dots\dots\dots$ [3]

- 4 Here are the first three patterns in a sequence.

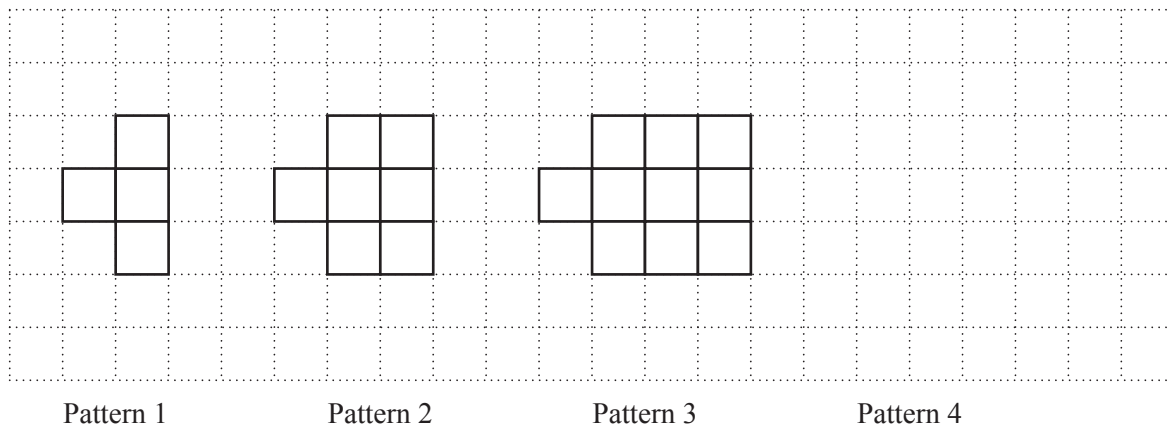

- (a) In the space above, draw Pattern 4. [1]
- (b) Complete the table.

Pattern Number	1	2	3	4	5
Number of squares	4	7	10		

[1]

- (c) Explain how you can find the number of squares in Pattern 5 without drawing it.

.....

..... [1]

- (d) Tom thinks the formula for the number of squares in Pattern n is $n + 3$.
Sarah thinks the formula is $3n + 1$.

Is Tom correct? Is Sarah correct?
Show clearly how you decide.

[3]

5 Sammy lives $6\frac{1}{4}$ km from school.

(a) Calculate the total distance that Sammy will travel to school **and back** in 5 days.

..... km [2]

(b) The bus that Sammy catches travels the $6\frac{1}{4}$ km at an average speed of 30 km/h.

Work out the time the bus takes to get to school.
Give your answer in minutes and seconds.

..... minutes seconds [4]

6 (a) Find the value of $6x + 9y$ when $x = 2$ and $y = 5$.

..... [2]

(b) Simplify.

$$6x + 9 - x + 4$$

..... [2]

(c) Factorise.

$$6x + 9y$$

..... [1]

7 A piece of cheese is in the shape of a prism.

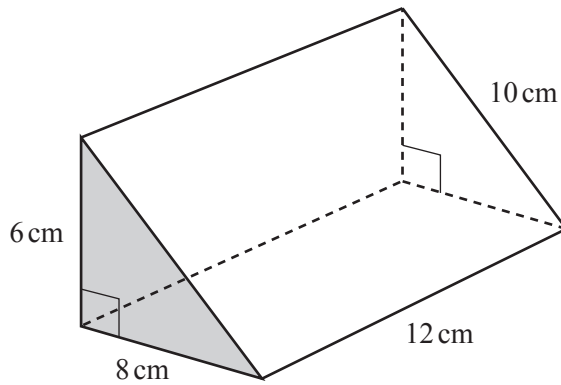

NOT TO SCALE

(a) Work out the area of the shaded triangle.

..... cm² [2]

(b) Work out the total surface area of the cheese.

..... cm² [3]

(c) Calculate the volume of the cheese.

..... cm³ [1]

8 Aisha owns a shop.

(a) In the shop, 5 chocolate bars cost a total of \$8.95.

Work out how much 9 of these chocolate bars cost.

\$ [3]

(b) Aisha bought cans of drink for \$1.20 each.
She wants to sell these cans to make a profit of 15%.

Work out how much she should sell each can for.

\$ [3]

(c) She bought cakes for \$5.50 each and sold them for \$4.84 each.

Work out the percentage loss on each cake.

..... % [3]

9 Solve these equations.

(a) $\frac{x}{5} = 2$

$x = \dots\dots\dots$ [1]

(b) $3(2x - 1) = 9$

$x = \dots\dots\dots$ [3]

(c) $7x + 2 = 20 + 3x$

$x = \dots\dots\dots$ [3]

10 (a) Complete the table of values for $y = 3 \times 2^x$.

x	-2	-1	0	1	2	3
y	0.75	1.5				

[1]

(b) On the diagram, sketch the graph of $y = 3 \times 2^x$ for $-2 \leq x \leq 3$.

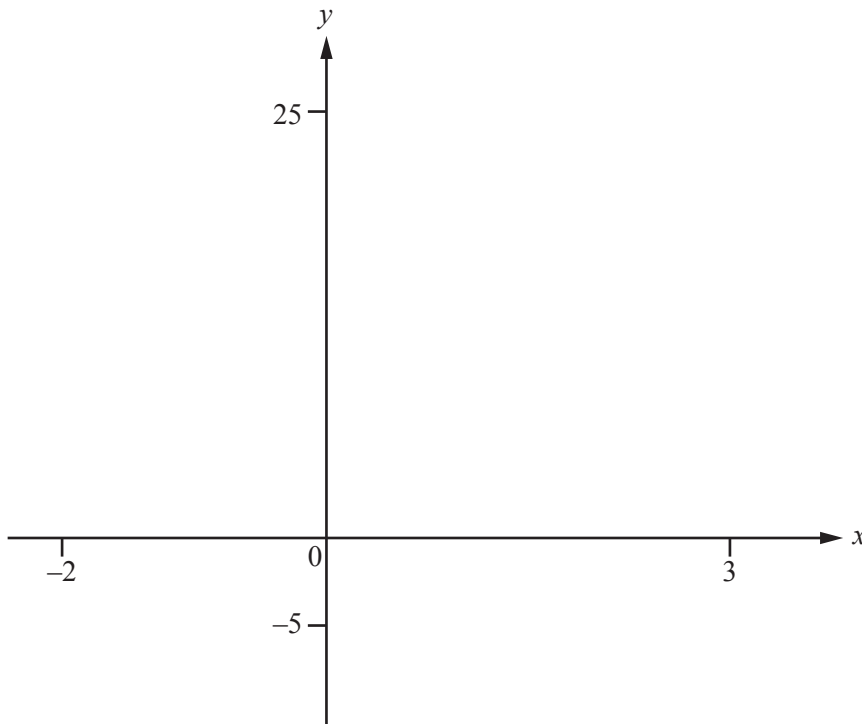

[2]

(c) (i) On the diagram, sketch the line $y = 8$.

[1]

(ii) Find the value of x where the graphs of $y = 3 \times 2^x$ and $y = 8$ intersect.

$x = \dots\dots\dots$ [1]

- 11 (a) Steve is growing plants.
Here are the heights, in centimetres, of 11 plants that he grows.

27 30 10 25 41 32 27 12 20 29 17

Work out the median and inter-quartile range of these heights.

Median = cm

Inter-quartile range = cm [3]

- (b) Tam is growing the same type of plants.
The cumulative frequency curve shows the heights of 80 plants that she grows.

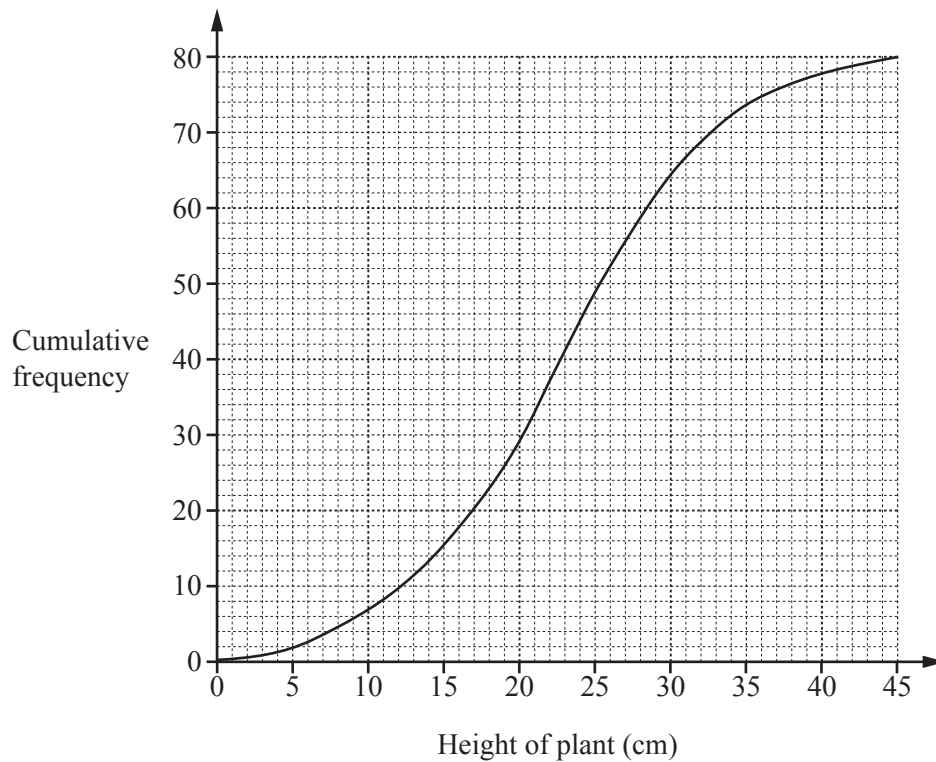

Find the median and inter-quartile range of the heights of Tam's plants.

Median = cm

Inter-quartile range = cm [3]

(c) Use your answers to **part (a)** and **part (b)** to compare the heights of Steve's plants and Tam's plants.

.....

.....

.....

..... [2]

- 12 Marcel has a box of coloured beads.

He takes a bead from the box at random, writes down its colour and returns it to the box.

He repeats this 200 times.

His results are shown in the table.

Colour	Red	White	Blue
Number	91	42	67

- (a) Use the information given to complete the relative frequencies in the table below.
Write each value as a decimal.

Colour	Red	White	Blue
Relative frequency	0.455		

[2]

- (b) Give a reason why the information in **part (a)** gives a good estimate of the probability of taking each of the colours from the box.

.....
..... [1]

- (c) There are 5000 beads in the box.

Calculate an estimate of the number of blue beads in the box.

..... [2]

- (d) Marcel selects a bead from the box at random.

Calculate an estimate of the probability that the bead is red or white.

..... [2]

- 13 This is an important formula in physics.

$$E = mc^2$$

- (a) Work out the value of E when $m = 1.3 \times 10^{-4}$ and $c = 3.0 \times 10^8$.
Give your answer in standard form.

..... [2]

- (b) Write 1.3×10^{-4} as an ordinary number.

..... [1]

- (c) Rearrange the formula $E = mc^2$ to make c the subject.

$c =$ [2]

- 14 The diagram shows the frame of a window made from metal rods. The shape is a rectangle with a semi-circle on top.

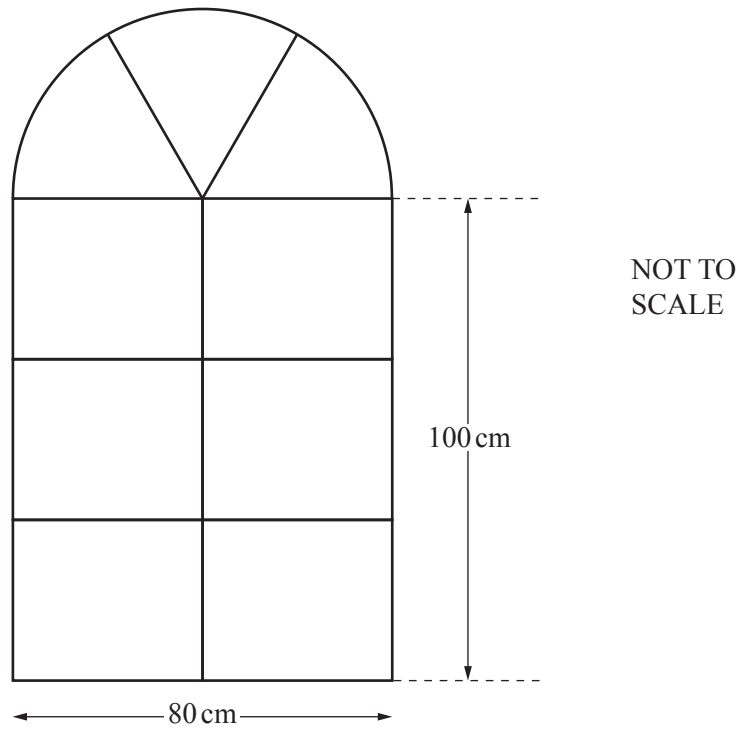

Work out the total length of the metal rods needed to make the window frame.

..... cm [6]

15 (a)

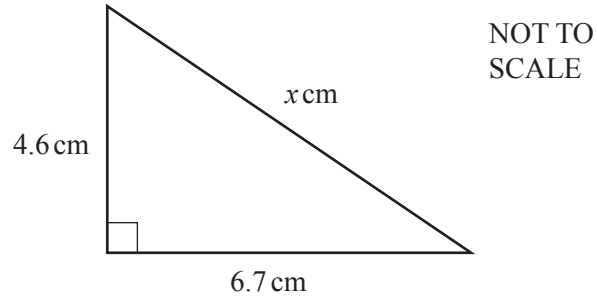

Find the value of x .

$x = \dots\dots\dots$ [2]

(b) Here is another right-angled triangle.

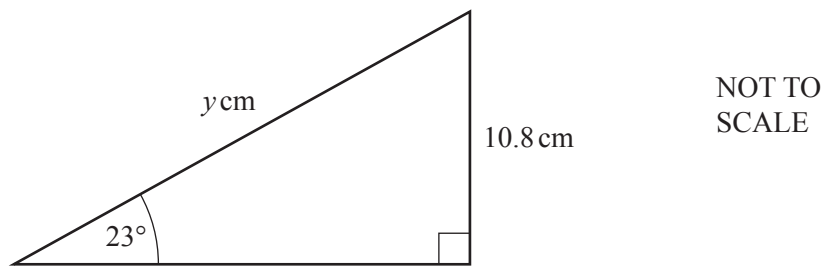

Use trigonometry to find the value of y .

$y = \dots\dots\dots$ [3]

BLANK PAGE

Permission to reproduce items where third-party owned material protected by copyright is included has been sought and cleared where possible. Every reasonable effort has been made by the publisher (UCLES) to trace copyright holders, but if any items requiring clearance have unwittingly been included, the publisher will be pleased to make amends at the earliest possible opportunity.

To avoid the issue of disclosure of answer-related information to candidates, all copyright acknowledgements are reproduced online in the Cambridge International Examinations Copyright Acknowledgements Booklet. This is produced for each series of examinations and is freely available to download at www.cie.org.uk after the live examination series.

Cambridge International Examinations is part of the Cambridge Assessment Group. Cambridge Assessment is the brand name of University of Cambridge Local Examinations Syndicate (UCLES), which is itself a department of the University of Cambridge.