



Cambridge IGCSE™

PHYSICAL SCIENCE

0652/51

Paper 5 Practical Test

October/November 2021

CONFIDENTIAL INSTRUCTIONS

This document gives details of how to prepare for and administer the practical exam.

The information in this document and the identity of any materials supplied by Cambridge International are confidential and must NOT reach candidates either directly or indirectly.

The supervisor must complete the report at the end of this document and return it with the scripts.

INSTRUCTIONS

- If you have any queries regarding these confidential instructions, contact Cambridge International stating the centre number, the syllabus and component number and the nature of the query.
email info@cambridgeinternational.org
phone +44 1223 553554

This document has **8** pages.

General information about practical exams

Centres must follow the guidance on science practical exams given in the *Cambridge Handbook*.

Safety

Supervisors must follow national and local regulations relating to safety and first aid.

Only those procedures described in the question paper should be attempted.

Supervisors must inform candidates that materials and apparatus used in the exam should be treated with caution. Suitable eye protection should be used where necessary.

The following hazard codes are used in these confidential instructions, where relevant:

C	corrosive	MH	moderate hazard
HH	health hazard	T	acutely toxic
F	flammable	O	oxidising
N	hazardous to the aquatic environment		

Hazard data sheets relating to substances used in this exam should be available from your chemical supplier.

Before the exam

- The packets containing the question papers must **not** be opened before the exam.
- It is assumed that standard school laboratory facilities, as indicated in the *Guide to Planning Practical Science*, will be available.
- Spare materials and apparatus for the tasks set must be available for candidates, if required.

During the exam

- It must be made clear to candidates at the start of the exam that they may request spare materials and apparatus for the tasks set.
- Where specified, the supervisor **must** perform the experiments and record the results as instructed. This must be done **out of sight** of the candidates, using the same materials and apparatus as the candidates.
- Any assistance provided to candidates must be recorded in the supervisor's report.
- If any materials or apparatus need to be replaced, for example, in the event of breakage or loss, this must be recorded in the supervisor's report.

After the exam

- The supervisor must complete a report for each practical session held and each laboratory used.
- Each packet of scripts returned to Cambridge International must contain the following items:
 - the scripts of the candidates specified on the bar code label provided
 - the supervisor's results relevant to these candidates
 - the supervisor's reports relevant to these candidates
 - seating plans for each practical session, referring to each candidate by candidate number
 - the attendance register.

Specific information for this practical exam

During the exam, the supervisor (not the invigilator) must do the experiments in Questions 1, 2 and 3 and record the results on a spare copy of the question paper, clearly labelled 'supervisor's results'.

Question 1

Items to be supplied by the centre (per set of apparatus, unless otherwise specified):

- power supply of approximately 1.5V–2.0V. Where candidates are provided with a power supply with a variable output voltage, the voltage must be set by the supervisor and fixed (e.g. taped). See Note 2
- six resistors of nominal value $10\ \Omega$ with a power rating of at least 0.25 W. See Note 3
- switch. The switch may be an integral part of the power supply
- ammeter capable of reading up to 1.00 A, with a resolution of at least 0.05 A. See Note 4
- voltmeter capable of measuring the supply p.d. with a resolution of at least 0.05 V. See Note 4
- sufficient connecting leads to construct the circuit shown in Fig. 1.1, with six additional leads.

Notes

1. The circuit is to be connected by the supervisor as shown in Fig. 1.1. Points **P** and **Q** must be labelled. It must be possible for a candidate to connect a component into the circuit at points **P** and **Q**.

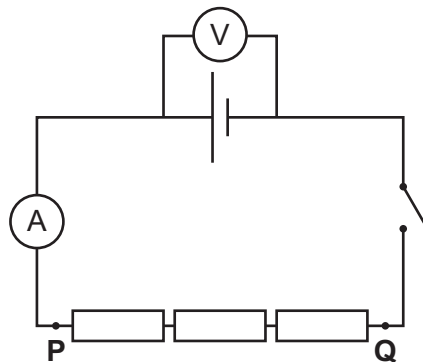

Fig. 1.1

2. If cells are to be used, they must remain adequately charged throughout the examination. Spare cells must be available.

3. Three resistors are required to set up the circuit in Fig. 1.1. The other three resistors must be arranged as shown in Fig. 1.2 and their arrangement must be hidden from the candidate's view (e.g. covered with a folded sheet of card taped at both ends or enclosed inside a small plastic or cardboard box). It must be possible for candidates to connect the hidden arrangement into a circuit. The arrangement should be labelled **unknown arrangement U**.

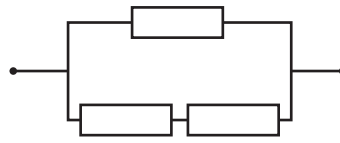

Fig. 1.2

4. Either analogue or digital meters are suitable. Any variable settings must be set by the supervisor and fixed (e.g. taped). Spare meters should be available.
5. Spare leads should be available.

Action at changeover

Set up the circuit so that it is arranged as shown in Fig. 1.1.

Check the circuit works. Open the switch.

Question 2

Items to be supplied by the centre (per set of apparatus, unless otherwise specified):

- metre rule with a scale graduated in mm. See Note 1
- triangular block to act as a pivot for the metre rule. This block is to stand on the bench
- mass of 200g labelled **mass**. The mass must be able to stand on the rule when it is balanced on the pivot. See Note 2.

Notes

1. The metre rule should approximately balance on the pivot, with the scale facing upwards, when the 50 cm mark is over the pivot.
2. The mass can be made from $2 \times 100\text{g}$ slotted masses held together by tape. Check that the masses can stand on the rule when the rule is balanced by balancing pairs of the masses to be supplied to the candidates on the ruler with the pivot placed under the 50 cm mark.

Action at changeover

Check that the apparatus is ready for the next candidate.

For Question 3

Each candidate will require:

- 50 cm³ aqueous ammonia 0.2 mol dm⁻³ labelled **Y**
 - 50 cm³ aqueous sodium hydroxide 0.05 mol dm⁻³ labelled **X**
 - 50 cm³ aqueous sodium hydroxide 0.1 mol dm⁻³ labelled **Z**
 - 50 cm³ dilute hydrochloric acid 1.0 mol dm⁻³ labelled **dilute hydrochloric acid**
- [C][N]**
- 20 cm³ aqueous copper(II) sulfate 0.2 mol dm⁻³ labelled **aqueous copper sulfate [C][N]**
 - universal indicator solution labelled **universal indicator**, with narrow dropper supplied
 - bromophenol blue indicator in bottle labelled **bromophenol blue** with dropper or pipette supplied
 - strip of chromatography paper long enough to wrap around a glass rod and dangle into 1 cm depth of water in the beaker supplied
 - a 100 cm³ or 250 cm³ beaker
 - a pencil
 - a ruler 15 or 30 cm
 - glass rod
 - paper clip
 - white tile
 - dropping pipette
 - 25 cm³ measuring cylinder (or 50 cm³)
 - conical flask
 - 2 test-tubes approximately 125 mm × 15 mm and a means to support them
 - access to distilled / deionised water labelled **distilled water**
 - paper towels.

Action at changeover

Check that the apparatus, chemicals and solutions are ready for the next candidate.

For Question 4

Nothing is required.

Permission to reproduce items where third-party owned material protected by copyright is included has been sought and cleared where possible. Every reasonable effort has been made by the publisher (UCLES) to trace copyright holders, but if any items requiring clearance have unwittingly been included, the publisher will be pleased to make amends at the earliest possible opportunity.

To avoid the issue of disclosure of answer-related information to candidates, all copyright acknowledgements are reproduced online in the Cambridge Assessment International Education Copyright Acknowledgements Booklet. This is produced for each series of examinations and is freely available to download at www.cambridgeinternational.org after the live examination series.

Cambridge Assessment International Education is part of the Cambridge Assessment Group. Cambridge Assessment is the brand name of the University of Cambridge Local Examinations Syndicate (UCLES), which itself is a department of the University of Cambridge.

Supervisor's report

Syllabus and component number

				/		
--	--	--	--	---	--	--

Centre number

--	--	--	--	--

Centre name

Time of the practical session

Laboratory name/number

Give details of any difficulties experienced by the centre or by candidates (include the relevant candidate names and candidate numbers).

You must include:

- any difficulties experienced by the centre in the preparation of materials
- any difficulties experienced by candidates, e.g. due to faulty materials or apparatus
- any specific assistance given to candidates.

Declaration

- 1 Each packet that I am returning to Cambridge International contains all of the following items:
 - the scripts of the candidates specified on the bar code label provided
 - the supervisor's results relevant to these candidates
 - the supervisor's reports relevant to these candidates
 - seating plans for each practical session, referring to each candidate by candidate number
 - the attendance register.
- 2 Where the practical exam has taken place in more than one practical session, I have clearly labelled the supervisor's results, supervisor's reports and seating plans with the time and laboratory name/number for each practical session.
- 3 I have included details of difficulties relating to each practical session experienced by the centre or by candidates.
- 4 I have reported any other adverse circumstances affecting candidates, e.g. illness, bereavement or temporary injury, directly to Cambridge International on a *special consideration form*.

Signed (supervisor)

Name (in block capitals)