



UNIVERSITY OF CAMBRIDGE INTERNATIONAL EXAMINATIONS
International General Certificate of Secondary Education

PHYSICS

0625/05

Paper 5 Practical Test

May/June 2004

1 hour 15 minutes

Additional Materials: As specified in the Confidential Instructions

READ THESE INSTRUCTIONS FIRST

Follow the instructions on the front cover of the Answer Booklet.
Write your answers in the spaces provided in the Answer Booklet.

Answer **all** questions.

You are expected to record all your observations as soon as these observations are made.

An account of the method of carrying out the experiments is **not** required.

At the end of the examination, hand in only the Answer Booklet.

- 1 In this experiment, you are to investigate the heating of a thermometer bulb.

Record all of your observations on page 2 of your Answer Booklet.

Carry out the following instructions, referring to Fig. 1.1.

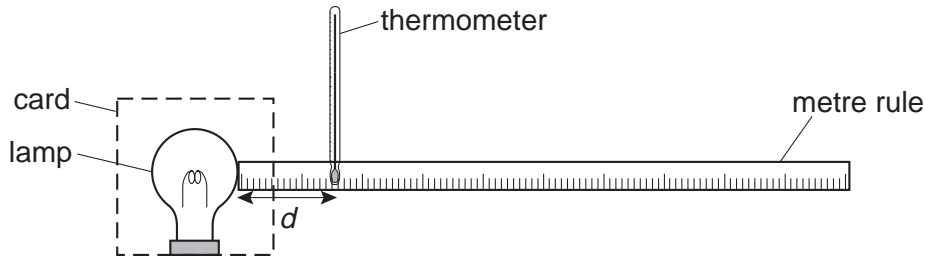

Fig. 1.1

During the experiment, you will read temperature values from the thermometer. You may find it more comfortable to use the card provided to shield your eyes from the direct rays of the lamp. Do **not** place the card between the lamp and the thermometer.

You are provided with a lamp and a scale marked in 1 mm divisions. Do **not** move the lamp or the scale.

- Switch on the lamp. Leave the lamp switched on until you have completed all the readings.
- Place the thermometer so that its bulb is a distance $d = 100$ mm from the surface of the lamp, as shown by the scale provided. Wait for about 30 s. In the table, record the distance d between the thermometer bulb and the surface of the lamp and the temperature θ shown on the thermometer.
- Move the thermometer so that its bulb is a distance $d = 80$ mm from the surface of the lamp. Wait for about 30 s. In the table, record the distance d and the temperature θ .
- Repeat the steps described in (c), but using values of d of 60 mm, 40 mm, 20 mm and 10 mm.
- Complete the column headings in the table.
- Use the data in the table to plot a graph of temperature (y -axis) against distance (x -axis).
- Use your graph to estimate room temperature. Explain briefly how you obtained your estimate.

- 2 In this experiment, you are to compare the combined resistance of lamps in different arrangements.

Record all of your observations and readings on page 4 of your Answer Booklet.

The circuit shown in Fig. 2.1 has been set up for you.

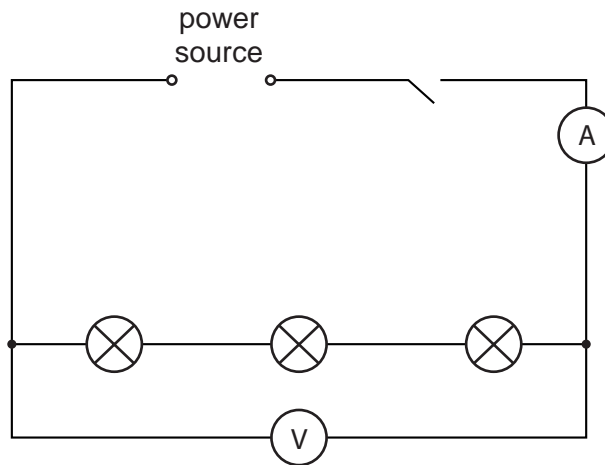

Fig. 2.1

- (a) Switch on. Measure and record in the table the current I in the circuit and the p.d. V across the three lamps. Switch off.
- (b) Calculate the combined resistance R of the three lamps using the equation

$$R = \frac{V}{I}.$$

Record this value of R in the table.

- (c) Complete the column headings for each of the I , V and R columns of the table.
- (d) Disconnect the lamps and the voltmeter and set up the circuit shown in Fig. 2.2.

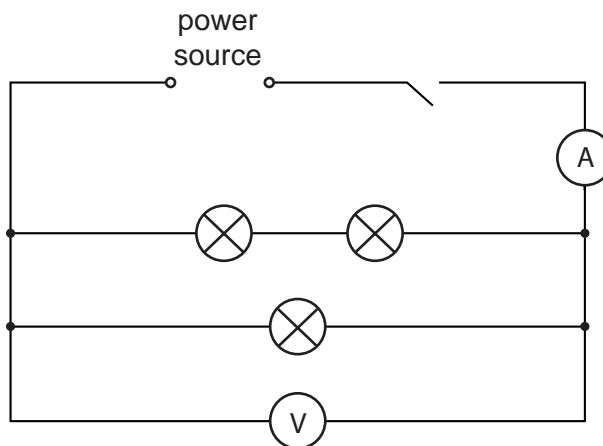

Fig. 2.2

- (e) Switch on. Measure and record in the table the current I in the circuit and the p.d. across the three lamps. Switch off.
- (f) Calculate the combined resistance R of the three lamps using the equation

$$R = \frac{V}{I}.$$

Record this value of R in the table.

- (g) Disconnect the lamps and the voltmeter and set up the circuit shown in Fig. 2.3.

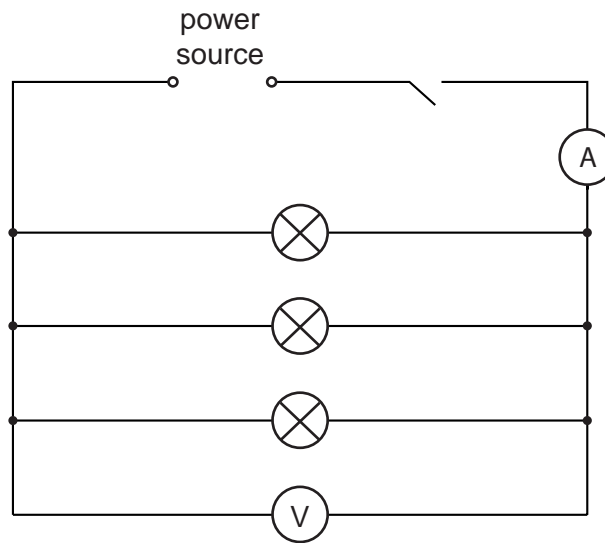

Fig. 2.3

- (h) Switch on. Measure and record in the table the current I in the circuit and the p.d. V across the three lamps. Switch off.
- (i) Calculate the combined resistance R of the three lamps using the equation

$$R = \frac{V}{I}.$$

Record this value of R in the table.

- (j) Draw a circuit showing the same components as in Fig. 2.3 but with two lamps in parallel with each other and another lamp in series with the first two. Also include the ammeter to measure the total current in the circuit and the voltmeter to measure the p.d. across the complete combination of lamps.

You are not asked to set up this circuit.

3 In this experiment, you are to investigate the period of oscillation of a rule attached to a spring.

Record all of your observations on page 5 of your Answer Booklet.

Carry out the following instructions, referring to Fig. 3.1.

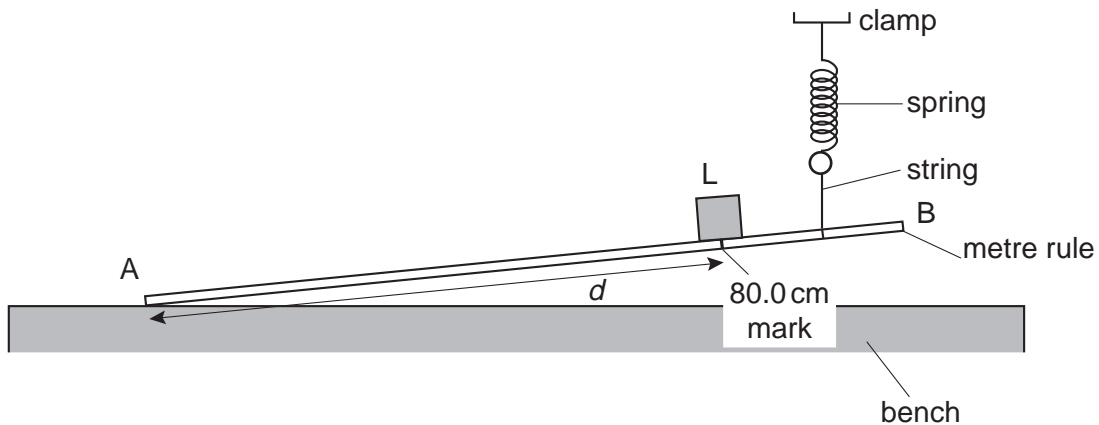

Fig. 3.1

The rule has one end lightly taped to the bench so that it does not slip. The other end is attached to a spring. Do **not** change the position of the spring.

- Place the load L on the rule so that its centre is over the 80.0 cm mark. Record the distance d from the centre of the load to the end A of the rule.
- Displace the end B of the rule a small distance downwards and release it so that it oscillates. Record the time t taken for 10 complete oscillations of the rule.
- Calculate the period T of the oscillations. T is the time for one complete oscillation.
- Calculate the value of $\frac{T}{d}$.
- Repeat steps (a) – (d) using values for d of 70.0 cm, 60.0 cm, 50.0 cm, 40.0 cm and 30.0 cm.
- Complete the column headings in the table.
- Draw a labelled diagram to show how you judged the centre of the load to be exactly over the 80.0 cm mark on the rule.
- A student suggests that T should be directly proportional to d . State with a reason whether your results support this suggestion.

- 4 In this experiment, you are to investigate the magnification of an image produced by a converging lens.

Record all of your observations on page 6 of your Answer Booklet.

Carry out the following instructions, referring to Fig. 4.1.

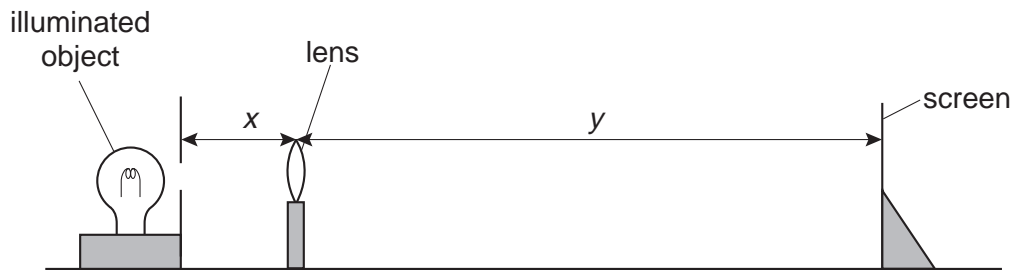

Fig. 4.1

- (a) Place the lens at a distance $x = 25.0$ cm from the illuminated object. Place the screen close to the lens, then move it away from the lens until a sharply-focused image is formed on the screen. Measure and record the distance y between the lens and the screen.
- (b) Calculate the value of the ratio y/x .
- (c) Measure the height h of the focused image.
- (d) Calculate the magnification m using the equation $m = h/k$ where $k = 1.5$ cm.
- (e) Repeat steps (a) – (d) using values of x of 30.0 cm and 35.0 cm.
- (f) Look at the values of y/x and m that you have obtained. Within the limits of experimental error, what do you conclude about the relationship between y/x and m ?

Copyright Acknowledgements

Every reasonable effort has been made to trace all copyright holders. The publishers would be pleased to hear from anyone whose rights we have unwittingly infringed.

University of Cambridge International Examinations is part of the University of Cambridge Local Examinations Syndicate (UCLES), which is itself a department