



UNIVERSITY OF CAMBRIDGE INTERNATIONAL EXAMINATIONS  
International General Certificate of Secondary Education

CANDIDATE  
NAME

CENTRE  
NUMBER

--	--	--	--	--

CANDIDATE  
NUMBER

--	--	--	--



**PHYSICS**

**0625/61**

Paper 6 Alternative to Practical

**October/November 2011**

**1 hour**

Candidates answer on the Question Paper

No Additional Materials are required.

**READ THESE INSTRUCTIONS FIRST**

Write your Centre number, candidate number and name in the spaces at the top of the page.

Write in dark blue or black pen.

You may use a pencil for any diagrams, graphs or rough working.

Do not use staples, paper clips, highlighters, glue or correction fluid.

DO **NOT** WRITE IN ANY BARCODES.

Answer **all** questions.

At the end of the examination, fasten all your work securely together.

The number of marks is given in brackets [ ] at the end of each question or part question.

This document consists of **12** printed pages.



- 1 An IGCSE student is determining the weight of a metre rule.

Fig. 1.1 shows the apparatus.

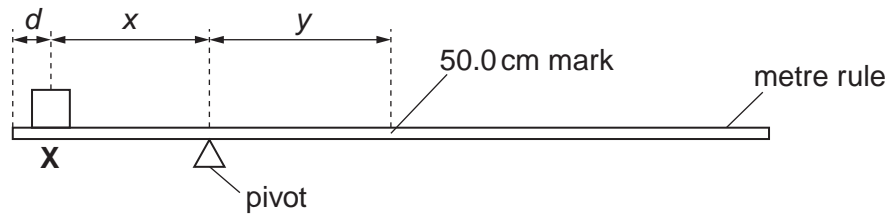

**Fig. 1.1**

**X** is a 1.0N load.

The student places the load **X** on the rule so that its centre is at  $d = 5.0$  cm from the zero end of the rule, as shown in Fig.1.1. He adjusts the position of the rule so that it is as near as possible to being balanced, with the 50.0 cm mark to the right of the pivot.

He measures and records the distance  $x$  from the centre of the load **X** to the pivot, and the distance  $y$  from the pivot to the 50.0 cm mark on the rule. He repeats the procedure using  $d$  values of 10.0 cm, 15.0 cm, 20.0 cm and 25.0 cm. The readings of  $d$ ,  $x$  and  $y$  are shown in Table 1.1.

**Table 1.1**

$d/\text{cm}$	$x/\text{cm}$	$y/\text{cm}$
5.0	23.7	21.3
10.0	21.0	19.1
15.0	18.5	16.3
20.0	16.0	14.1
25.0	13.9	12.0

- (a) Plot the graph of  $y/\text{cm}$  ( $y$ -axis) against  $x/\text{cm}$  ( $x$ -axis). You do not need to include (0,0) on your graph.

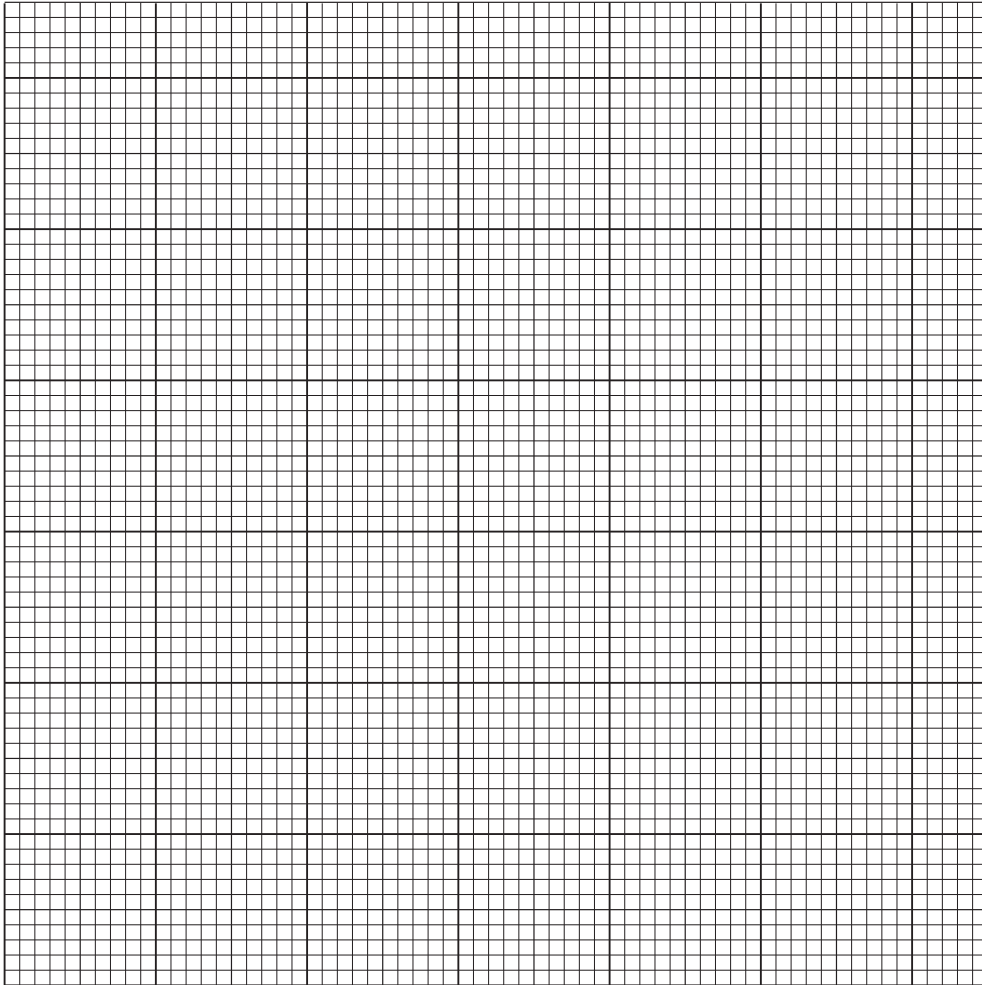

[4]

- (b) Determine the gradient  $G$  of the graph. Show clearly on the graph how you obtained the necessary information.

$G = \dots\dots\dots$  [2]

- (c) Calculate the weight  $W$  of the metre rule using the equation  $W = \frac{L}{G}$ , where  $L = 1.0\text{N}$ .

$W = \dots\dots\dots$  [1]

(d) The calculation of  $W$  is based on the assumption that the centre of mass of the rod is at the 50.0 cm mark.

(i) Describe briefly how you would determine the position of the centre of mass of the rod.

.....  
.....

(ii) Describe how you would modify the experiment if the centre of mass was at the 49.7 cm mark.

.....  
.....[2]

[Total: 9]

2 The IGCSE class is investigating temperature changes when cold water and hot water

- (a) A student records the temperature  $\theta_c$  of  $100\text{cm}^3$  of cold water and the temperature of  $100\text{cm}^3$  of hot water.

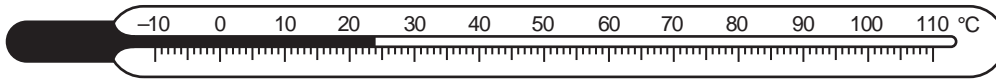

Fig. 2.1

Write down the temperature  $\theta_c$  shown on the thermometer in Fig. 2.1.

$\theta_c = \dots\dots\dots$  [2]

- (b) The hot water is at a temperature  $\theta_h = 86^\circ\text{C}$ .

Calculate  $\theta_{av}$ , the average of  $\theta_c$  and  $\theta_h$ .

average  $\theta_{av} = \dots\dots\dots$  [1]

- (c) The student adds  $100\text{cm}^3$  of the hot water to the cold water. She records the temperature  $\theta_m$  of the mixture of hot and cold water,  $\theta_m = 48^\circ\text{C}$ .

State two precautions (other than repeating the experiment) that the student could take to ensure the reliability of her value of the temperature  $\theta_m$ .

- 1. ....
  - 2. ....
- [2]

- (d) Suggest a practical reason in this experiment for the temperature of the mixture  $\theta_m$  being different from the average value  $\theta_{av}$ , even when the student has taken the precautions you suggested in (c).

.....  
.....[1]

- (e) Suggest a modification to the experiment which should reduce the difference between  $\theta_m$  and  $\theta_{av}$

.....  
.....[1]

- (f) The student decides to repeat the experiment to check the readings. Suggest one possible variable that she should keep constant.

.....[1]

3 The IGCSE class is investigating the current in resistors in a circuit.

The circuit is shown in Fig. 3.1.

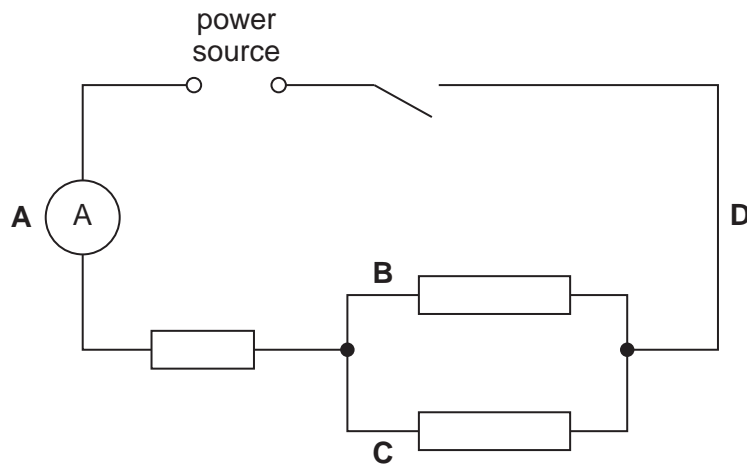

Fig. 3.1

(a) A student measures the current  $I_A$  at the position **A** shown by the ammeter, and then at positions **B** ( $I_B$ ), **C** ( $I_C$ ) and **D** ( $I_D$ ).

The readings are:

$I_A = 0.28 \text{ A}$

$I_B = 0.13 \text{ A}$

$I_C = 0.14 \text{ A}$

$I_D = 0.27 \text{ A}$

Theory suggests that  $I_A = I_B + I_C$  and  $I_D = I_B + I_C$ .

(i) Calculate  $I_B + I_C$ .

$I_B + I_C = \dots\dots\dots$

(ii) State whether the experimental results support the theory. Justify your statement by reference to the readings.

statement .....

justification .....

.....

.....

(b) The student suggests repeating the experiment to confirm her conclusion. She connects a variable resistor (rheostat) in series with the switch. State the purpose of the variable resistor.

.....  
.....[1]

(c) The student connects a voltmeter and records the potential difference  $V$  across the combination of the three resistors.

(i) On Fig. 3.1, draw in the voltmeter connected as described, using the standard symbol for a voltmeter. [1]

(ii) Write down the voltmeter reading shown on Fig. 3.2.

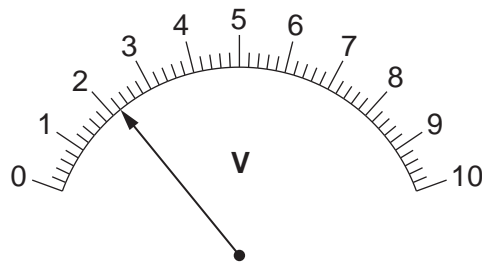

Fig. 3.2

$V =$  ..... [1]

(iii) Calculate the resistance  $R$  of the combination of the three resistors using the equation  $R = \frac{V}{I}$ .

$R =$  ..... [2]

[Total: 8]

4 An IGCSE student is investigating reflection of light in a plane mirror.

Fig. 4.1 shows the student's ray trace sheet.

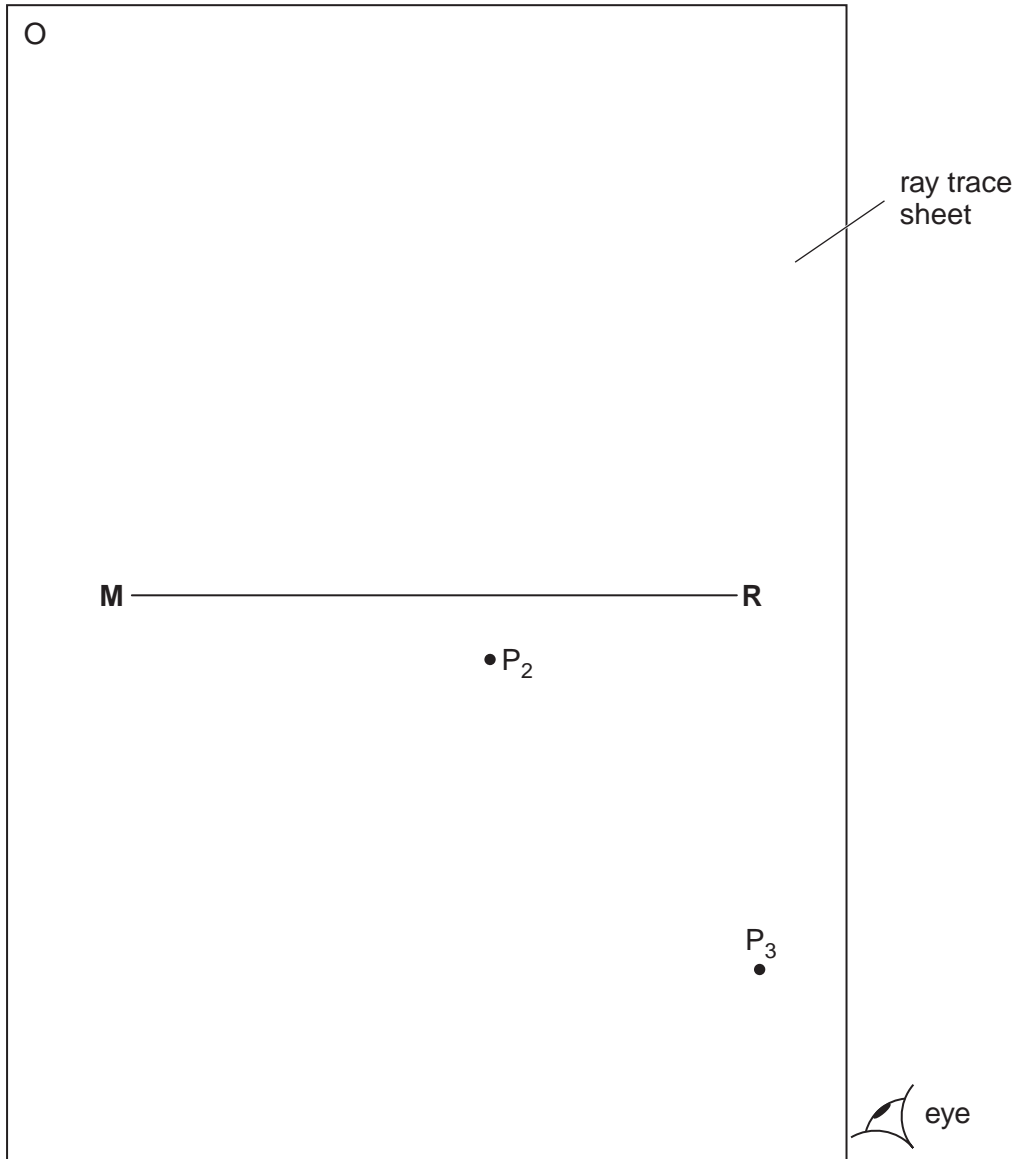

Fig. 4.1

(a) The line **MR** shows the position of a mirror.

(i) Draw a normal to this line that passes through its centre. Label the normal **NL**. Label the point at which **NL** crosses **MR** with the letter **B**.

[1]



- (ii) Draw a line 8cm long from **B** at an angle of incidence  $i = 40^\circ$  to the normal and to the left of the normal. Label the end of this line **A**. Record the angle of reflection in the first row of Table 4.1.

Table 4.1

$i/^\circ$	$r/^\circ$
34	33

[2]

- (b) Fig. 4.2 shows the mirror which is made of polished metal and has a vertical line drawn on it.

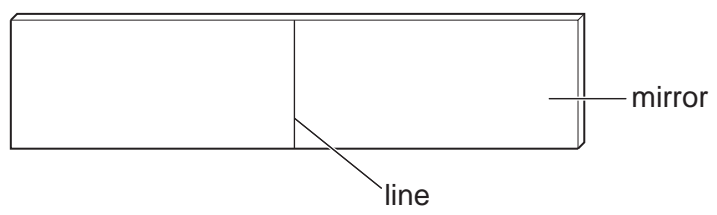

Fig. 4.2

The student places the mirror, with its reflecting face vertical, on **MR**. The lower end of the line on the mirror is at point **B**. He places a pin  $P_1$  at **A**. He views the line on the mirror and the image of pin  $P_1$  from the direction indicated by the eye in Fig. 4.1. He places two pins  $P_2$  and  $P_3$  some distance apart so that pins  $P_3$ ,  $P_2$ , the image of  $P_1$ , and the line on the mirror all appear exactly one behind the other. The positions of  $P_2$  and  $P_3$  are shown.

- (i) Draw the line joining the positions of  $P_2$  and  $P_3$ . Continue the line until it meets the normal.
- (ii) Measure, and record in the first row of Table 4.1, the angle of reflection  $r$  between the normal and the line passing through  $P_2$  and  $P_3$ .

[2]

- (c) The student draws a line parallel to **MR** and 2 cm above it. He places the mirror on this line and repeats the procedure without changing the position of pin  $P_1$ . His readings for  $i$  and  $r$  are shown in the table.

In spite of carrying out this experiment with reasonable care, it is possible that the values of the angle of reflection  $r$  will not be exactly the same as the values obtained from theory. Suggest two possible causes of this inaccuracy.

1. ....  
 .....

2. ....  
 ..... [2]

10

- (d) The student was asked to list precautions that should be taken with this experiment to obtain readings that are as accurate as possible. Table 4.2 shows the suggestions.

Place a tick (✓) in the second column of the table next to each correctly suggested precaution.

**Table 4.2**

suggested precaution	
avoid parallax (line of sight) errors when taking readings with the protractor	
carry out the experiment in a darkened room	
draw the lines so that they are as thin as possible	
keep room temperature constant	
place pins $P_2$ and $P_3$ as far apart as possible	
use only two or three significant figures for the final answers	

[3]

[Total: 10]

5 The IGCSE class is carrying out an experiment to determine the speed of sound in air. Fig. 5.1 indicates the method used. The experiment is conducted outside the school building.

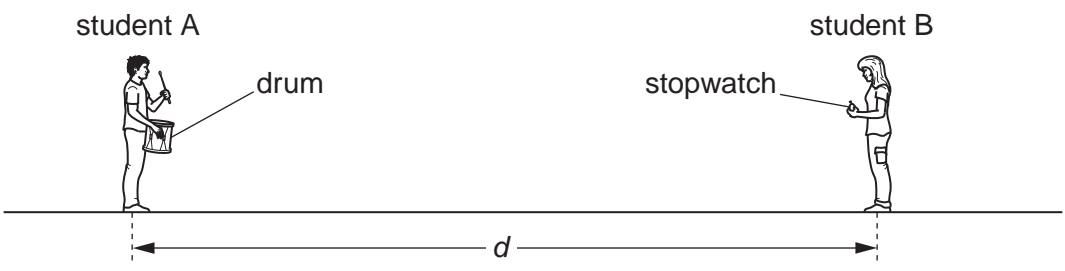

Fig. 5.1 (not to scale)

Student A strikes a drum once as loudly as possible. Student B stands some distance away from student A and starts a stopwatch when she sees the drum being hit. She stops the stopwatch when she hears the sound. She records the time interval  $t$  in Table 5.1. The experiment is repeated several times. She calculates the speed of sound  $v$  and enters the values in the table.

Table 5.1

$t/s$	$v/(m/s)$
0.87	344.83
0.92	326.09
0.84	357.14
0.83	361.45
0.86	338.84

(a) Suggest a suitable distance  $d$  for students to use when carrying out this experiment.

$d = \dots\dots\dots [1]$

(b) Suggest a suitable instrument for measuring the distance  $d$ .

$\dots\dots\dots [1]$

(c) Calculate the average value  $v_{av}$  for the speed of sound from the results in the table. Show your working.

$v_{av} = \dots\dots\dots [2]$

(d) The student has recorded the values for the speed of sound  $v$  to five significant figures. State whether this is a suitable number of significant figures for the speed of sound in this experiment. Give a reason for your answer.

statement .....

reason .....

.....[1]

[Total: 5]

---

Permission to reproduce items where third-party owned material protected by copyright is included has been sought and cleared where possible. Every reasonable effort has been made by the publisher (UCLES) to trace copyright holders, but if any items requiring clearance have unwittingly been included, the publisher will be pleased to make amends at the earliest possible opportunity.