



UNIVERSITY OF CAMBRIDGE INTERNATIONAL EXAMINATIONS  
International General Certificate of Secondary Education

CANDIDATE  
NAME

CENTRE  
NUMBER

--	--	--	--	--

CANDIDATE  
NUMBER

--	--	--	--

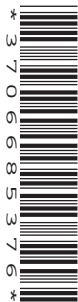

**PHYSICS**

**0625/22**

Paper 2 Core

**October/November 2012**

**1 hour 15 minutes**

Candidates answer on the Question Paper.

No Additional Materials are required.

**READ THESE INSTRUCTIONS FIRST**

Write your Centre number, candidate number and name on all the work you hand in.

Write in dark blue or black pen.

You may use a pencil for any diagrams or graphs.

Do not use staples, paper clips, highlighters, glue or correction fluid.

**DO NOT WRITE IN ANY BARCODES.**

Answer **all** questions.

You may lose marks if you do not show your working or if you do not use appropriate units.

Take the weight of 1 kg to be 10 N (i.e. acceleration of free fall = 10 m/s<sup>2</sup>).

At the end of the examination, fasten all your work securely together.

The number of marks is given in brackets [ ] at the end of each question or part question.

**For Examiner's Use**

1	
2	
3	
4	
5	
6	
7	
8	
9	
10	
11	
12	
<b>Total</b>	

This document consists of **19** printed pages and **1** blank page.



- 1 Fig. 1.1 shows the distance/time graph for a bus that goes to collect supporters for a football match and take them home to their villages.

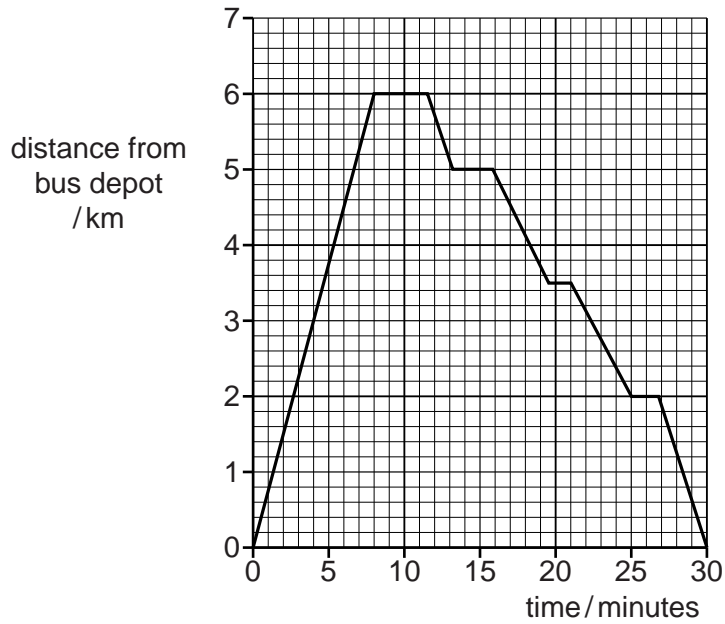

Fig. 1.1

- (a) The bus drives from its depot, without stopping, along the straight road to the football ground.

From Fig. 1.1, find

- (i) the distance from the bus depot to the football ground,

distance = ..... km [1]

- (ii) the time taken, in hours, to travel from the bus depot to the football ground,

time = ..... hours [2]

- (iii) the speed, in km/hour, of the bus on its journey to the football ground.

speed = ..... km/hour [3]

(b) State how you can tell from Fig. 1.1 that the bus travelled at a constant speed to the football ground.

.....  
..... [1]

(c) The bus returned to the depot by the same route, stopping a number of times to let supporters get off near to their home villages.

(i) At how many villages did the bus stop? ..... [1]

(ii) What was the smallest distance from a village to the football ground?

distance = ..... km [1]

[Total: 9]

- 2 (a) The length of a rectangular sheet of plastic is measured using a short ruler, as shown in Fig. 2.1 (not full size).

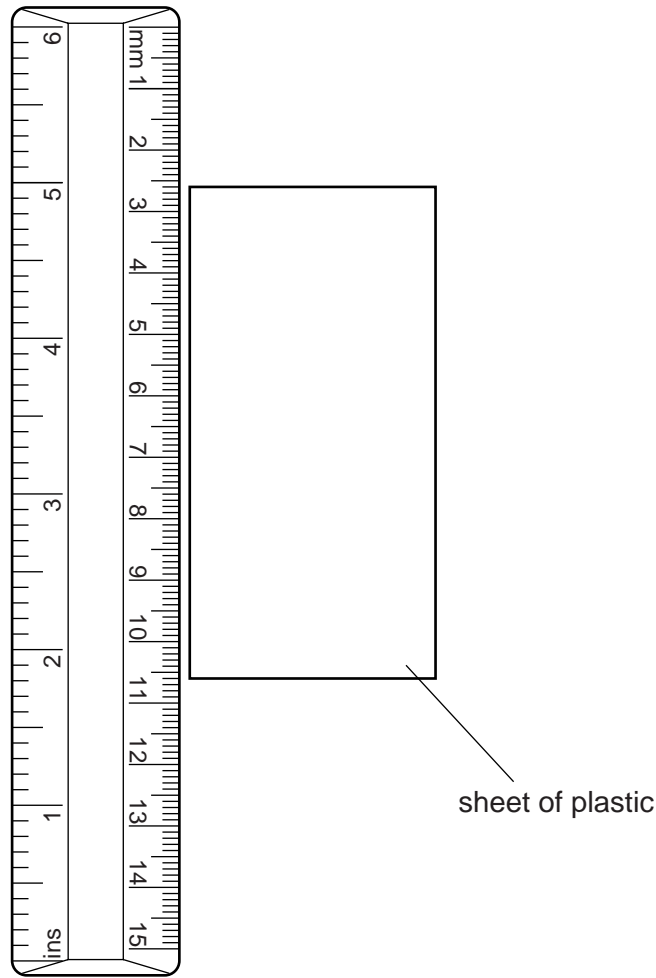

Fig. 2.1 (not full size)

From the ruler in Fig. 2.1, find the length, in cm, of the sheet.

length = ..... cm [1]

- (b) The sheet of plastic in (a) has a thickness of 0.50 cm and a width that is half its length.  
Calculate the volume of the sheet of plastic.

volume = ..... cm<sup>3</sup> [2]

5

(c) The plastic has a density of  $1.2\text{g/cm}^3$ .

(i) Calculate the mass of the sheet.

mass = ..... g [2]

(ii) Which laboratory instrument could be used to check the mass of the sheet?

..... [1]

[Total: 6]

- 3 Fig. 3.1 shows a manometer being used to measure the pressure of some gas in a container. The container is connected to the manometer by a length of rubber tubing.

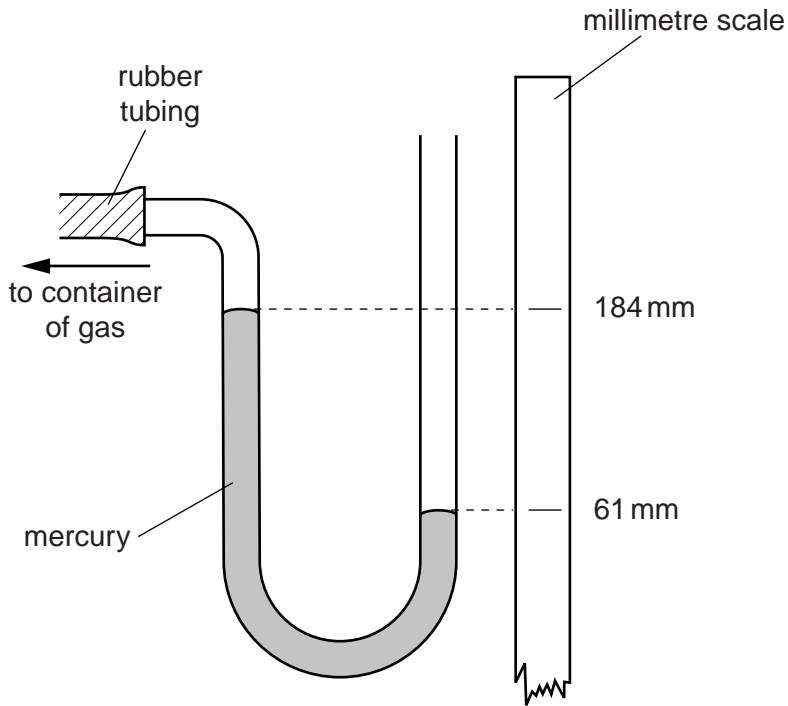

Fig. 3.1

- (a) State whether the pressure of the gas in the container is greater than, the same as, or less than the pressure of the atmosphere.

..... [1]

- (b) From Fig. 3.1, deduce the difference between the gas pressure and the atmospheric pressure.

difference in pressure = ..... mm of mercury [1]

- (c) The atmospheric pressure is 752 mm of mercury.

Calculate the actual pressure of the gas in the container.

pressure of gas = ..... mm of mercury [2]

- (d) State how the vertical height difference of the two mercury surfaces changes, if at all, if a mercury manometer made from a narrower tube is used.

..... [1]

- 4 A busy factory has a corner in a corridor where people are likely to collide. To avoid collisions, a plane mirror is fixed across the corner, as shown in Fig. 4.1.

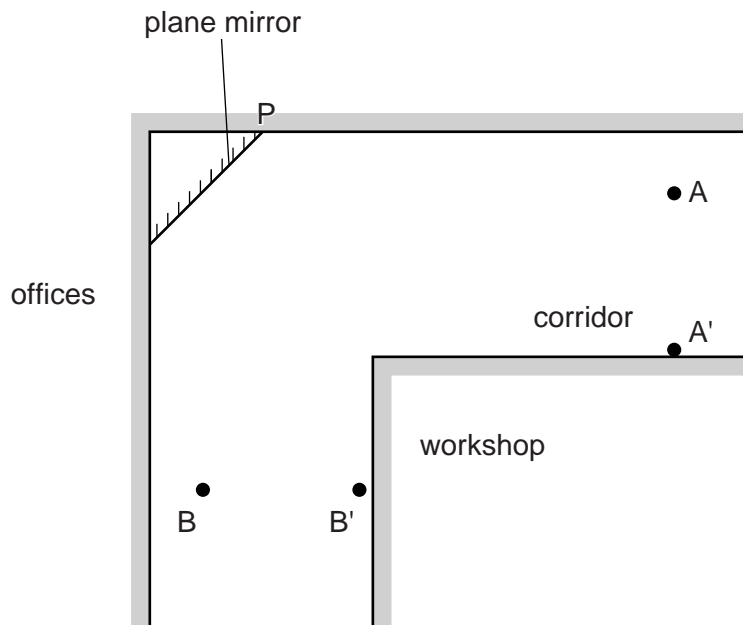

Fig. 4.1

- (a) Using this mirror, people at A and at B can see each other's reflections.

On Fig. 4.1, put X to show where the image of the person at A will be, as seen by the person at B. [2]

- (b) The two people move to A' and B' respectively.

(i) On Fig. 4.1, draw the normal to the mirror at end P. [1]

(ii) Draw lines on Fig. 4.1 to help you decide whether the two people can still see each other's reflections.

Can they still see each other's reflections? Having drawn your lines, tick one box below.

- definitely yes
- just about
- definitely no

[2]

5 A boy is sitting still on a swing that is oscillating from side to side, as shown in Fig. 5.1.

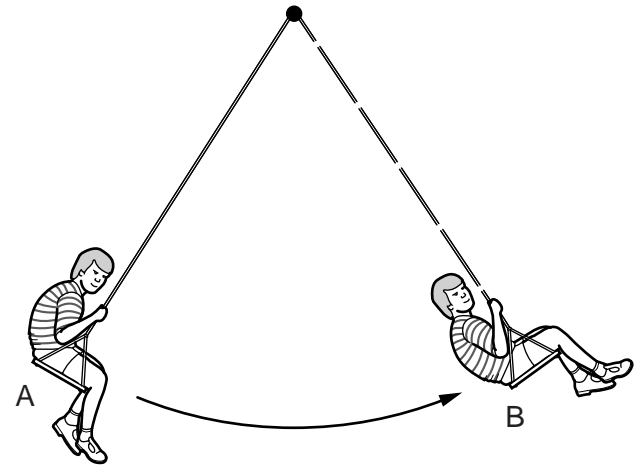

Fig. 5.1

(a) At the highest point of the oscillation, the boy's gravitational potential energy is 150 J more than it is at the lowest point of the oscillation.

State the value of the kinetic energy of the boy

- (i) at the highest point of the oscillation, ..... J
- (ii) at the lowest point of the oscillation. .... J

[2]

(b) The time for the boy to swing from A to B and back to A is approximately 3 s.

Describe how you would determine this time as accurately as possible. State the simple laboratory instrument you would use.

instrument used ..... [1]

method .....

.....

.....

.....

.....

..... [4]

[Total: 7]



6 (a) A crystal that dissolves slowly is put into some water in a beaker, as shown in Fig. 6.1

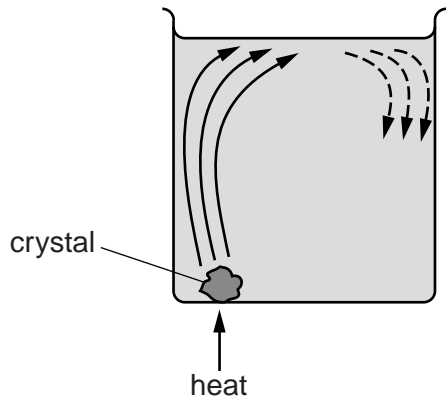

Fig. 6.1

As it dissolves, the crystal colours the water around itself. When the beaker is heated, the coloured water moves as shown in Fig. 6.1.

(i) What name is given to this movement of the water?  
.....[1]

(ii) Describe why this movement happens.  
.....  
.....  
.....  
.....  
.....  
.....  
.....[4]

(b) A decorator, up a step-ladder painting the ceiling of a room, comments, "It is hotter up here by the ceiling than it is down on the floor."

Explain why his observation is correct.  
.....  
.....  
.....[1]

[Total: 6]

7 Fig. 7.1 shows the regions of the electromagnetic spectrum. Two regions have no names, and there is an enlargement of the visible region.

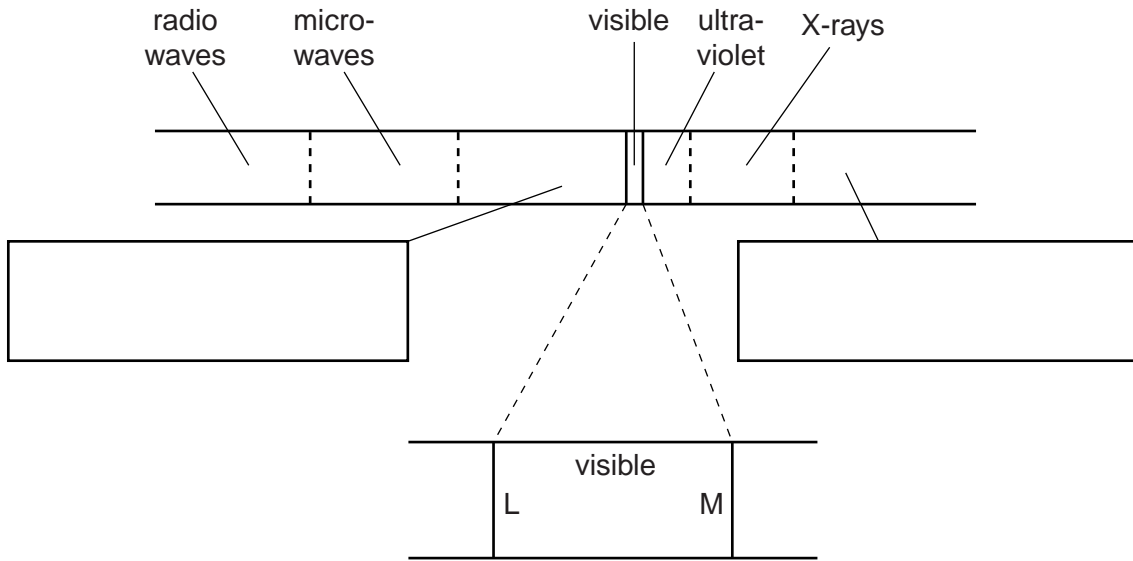

Fig. 7.1

(a) In the two boxes on Fig. 7.1, write the names of the regions they are indicating. [2]

(b) State the name of the colour of the light that is found

(i) at the end L of the visible spectrum, .....

(ii) at the end M of the visible spectrum. .... [2]

(c) (i) A man stands in the beam of light from a spot-lamp and finds that it makes him feel warm.

Which radiation, other than visible, does this observation show that the spotlight is emitting?

.....

(ii) Suggest one use to which X-rays are put.

..... [2]

(d) State one property, apart from their electromagnetic nature, that is the same for the radiations in all the regions of the electromagnetic spectrum.

..... [1]

[Total: 7]

8 A student has two wires A and B. She connects each in turn between the terminals P and Q in the circuit of Fig. 8.1.

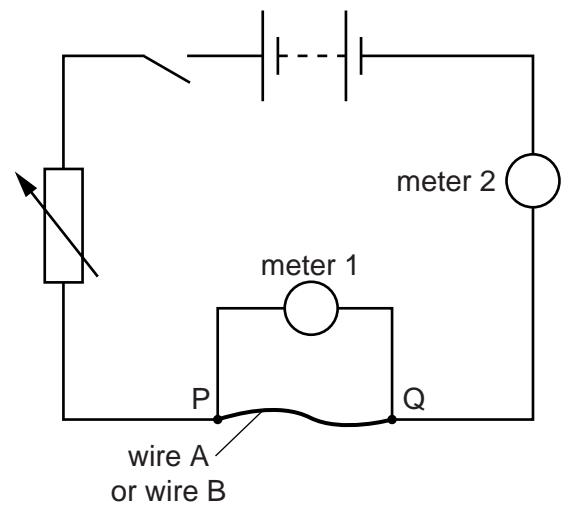

Fig. 8.1

For each wire, she measures the current in the wire when there are various potential differences across it.

- (a) (i) Which of the two meters measures the current? .....
- (ii) Name this type of meter. ....
- (b) (i) Which of the two meters measures the potential difference (p.d.)? .....
- (ii) Name this type of meter. ....

[2]

Question 8 continues on page 12.

(c) When the student draws the graphs of p.d. against current for the two wires, she gets the lines shown in Fig. 8.2.

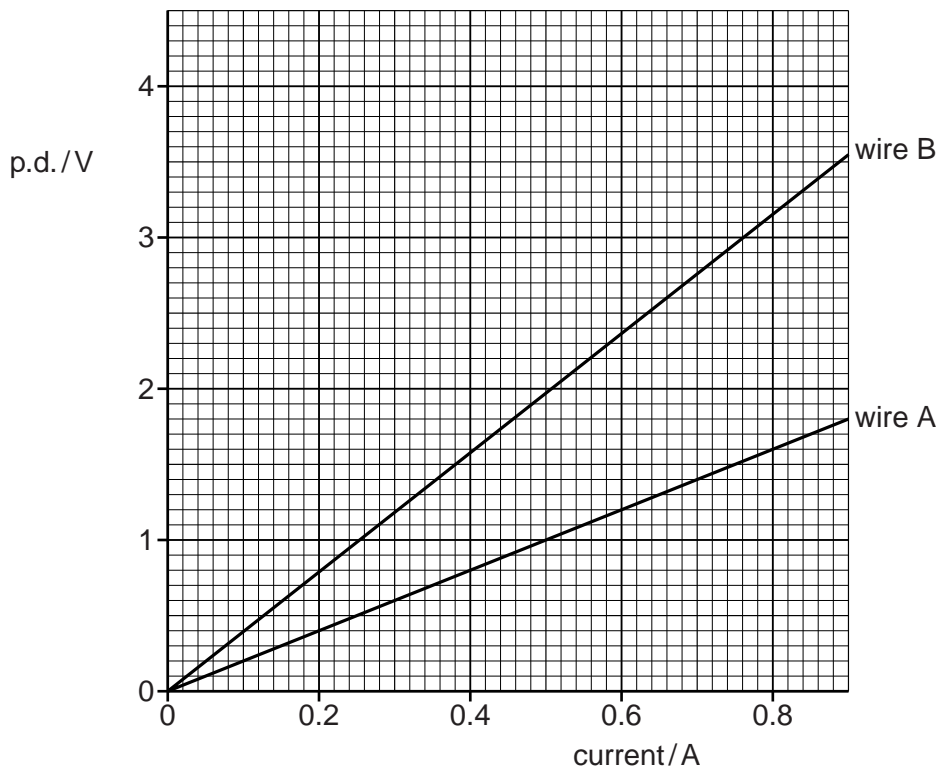

Fig. 8.2

(i) From Fig. 8.2, find the p.d. across wire A when there is a current of 0.8A in it.

p.d. = .....V [1]

(ii) Calculate the resistance of wire A when the current in it is 0.8A.

resistance = ..... [4]

(iii) From Fig. 8.2, how can you tell that the resistance of wire A remains constant during the experiment?

.....

.....

..... [1]

(iv) How can you tell that the resistance of wire B is greater than the resistance of wire A?

.....  
.....  
..... [1]

(v) Wires A and B are made of the same material and have the same thickness.  
State, giving your reasons, which of the wires is the longer wire.

.....  
.....  
..... [1]

[Total: 10]

9 In the circuit of Fig. 9.1, a 12V car battery is connected to three identical lamps and two switches. The resistance of the battery is so small that it may be ignored.

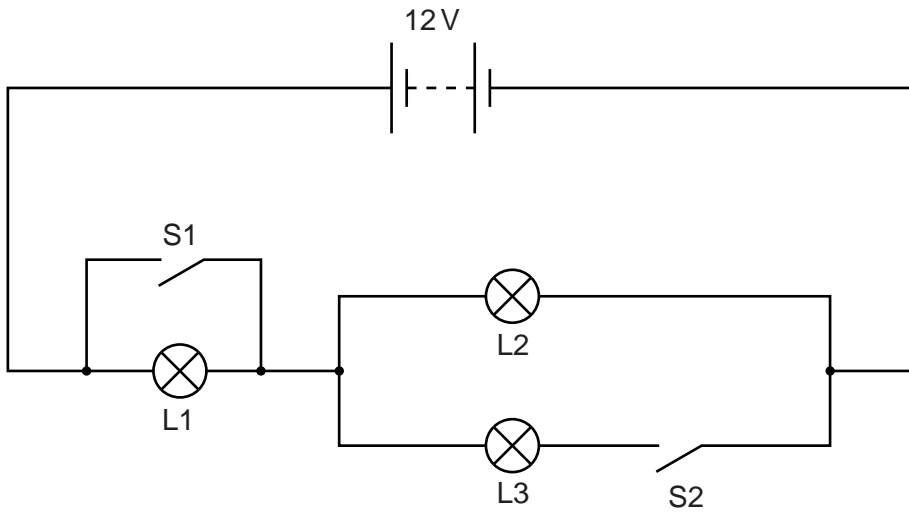

Fig. 9.1

- (a) (i) When switches S1 and S2 are both open, which two lamps are in series?  
..... and .....
- (ii) When switches S1 and S2 are both closed, which two lamps are in parallel?  
..... and .....

[2]

(b) Each of the three lamps glows with full brightness when there is a p.d. of 12V across each lamp.

With a smaller p.d., a lamp will glow with partial brightness.

With no p.d. across it, it will be off.

Complete the tables below, to show how the lamps glow with different switch combinations. Tick one box in each row.

switch combination: <b>S1 closed</b> and <b>S2 open</b>			
	full brightness	partial brightness	off
L1			
L2			
L3			

[2]

switch combination: <b>S1 open</b> and <b>S2 closed</b>			
	full brightness	partial brightness	off
L1			
L2			
L3			

[2]

[Total: 6]

10 A wire between the poles of a large horseshoe magnet is carrying a current.

Fig. 10.1 shows the direction of the force acting on the wire.

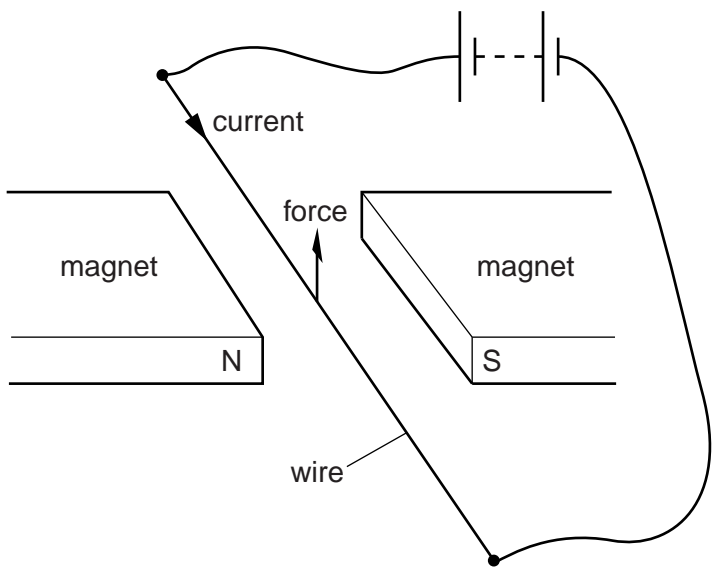

Fig. 10.1

(a) The magnetic poles are interchanged.

On Fig. 10.2 below, draw an arrow to show the direction of the force on the wire.

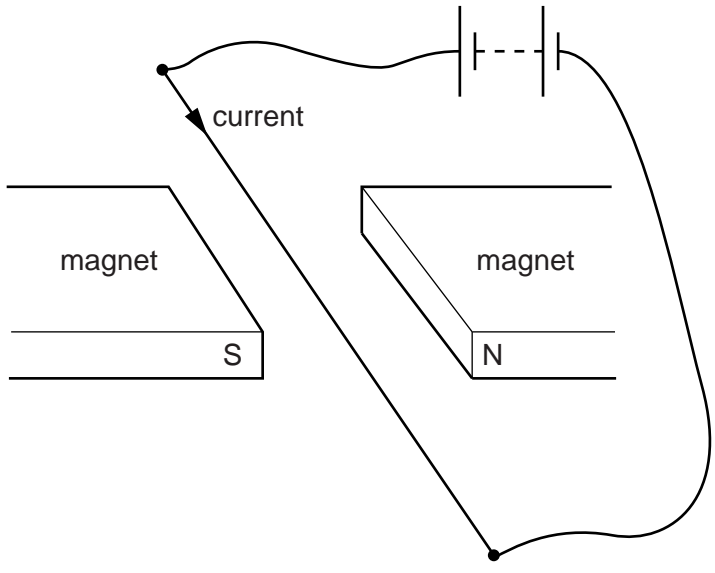

Fig. 10.2

[1]



(b) The battery is now reversed.

On Fig. 10.3 below, draw an arrow to show the direction of the force on the wire.

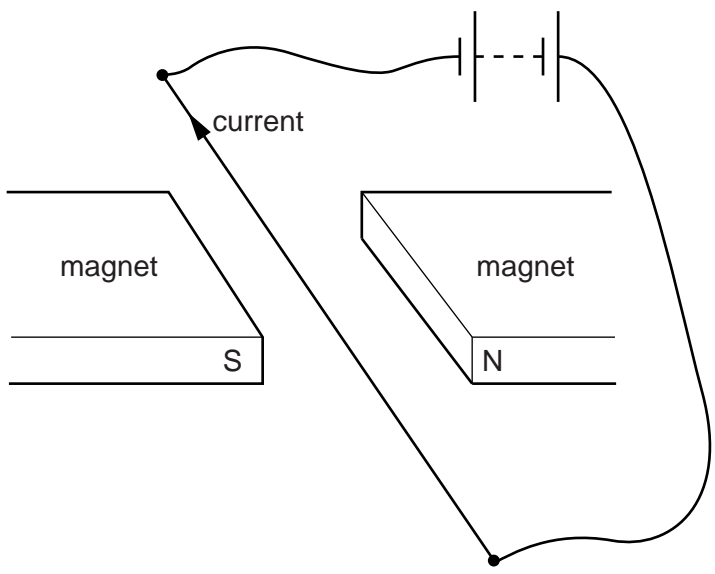

Fig. 10.3

[1]

(c) In the arrangement of Fig. 10.1 at the beginning of this question, the electromagnetic force on the wire is greater than the weight of the wire.

(i) Suggest what happens to the wire as the current is switched on.

.....  
..... [1]

(ii) Suggest one common device that makes use of this effect.

..... [1]

[Total: 4]

11 (a) What is meant by *radioactive decay*?

.....  
.....  
..... [3]

(b) Fig. 11.1 shows the decay curve for a particular radioactive substance.

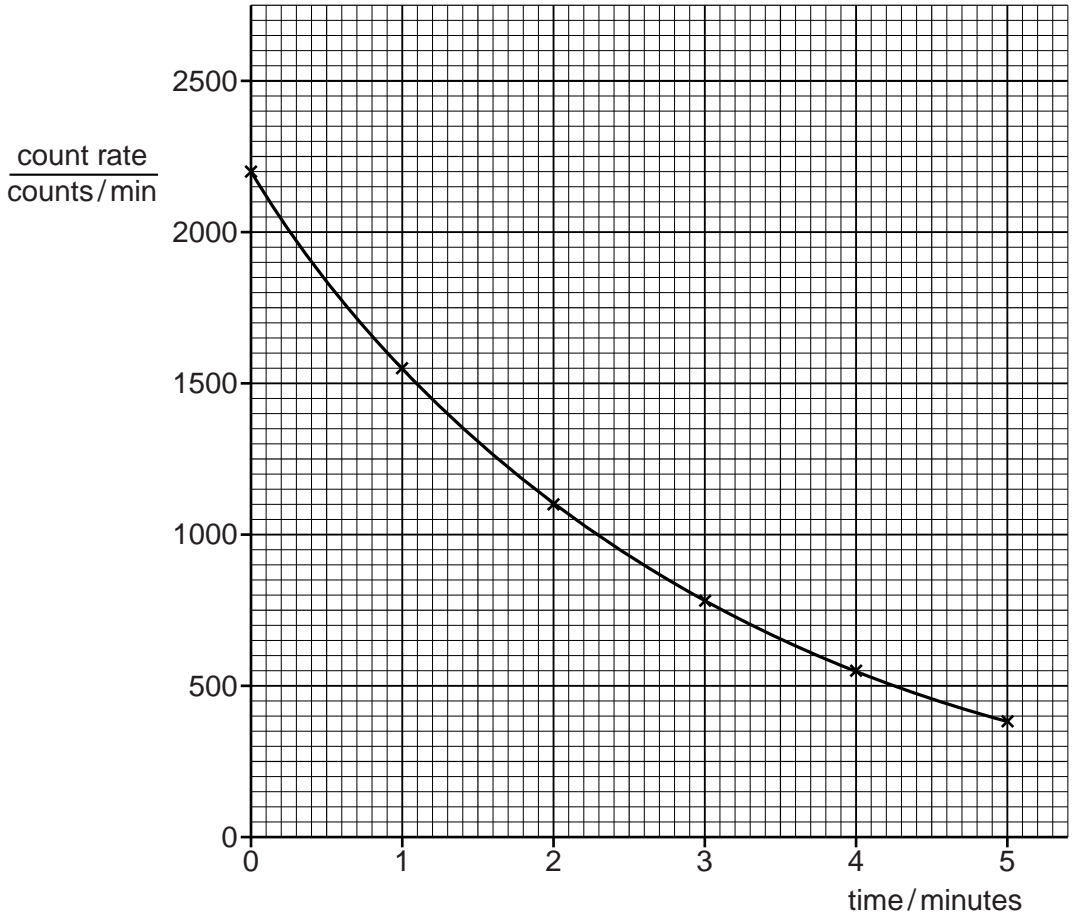

Fig. 11.1

(i) Use numbers from the graph to show that the half-life of the radioactive substance is 2 minutes.

[3]

(ii) Estimate the value of the count rate at a time of 6 minutes from the start of the measurements.

count rate = ..... counts/min [2]

[Total: 8]

12 Fig. 12.1 shows parts of a tube in which cathode rays are produced.

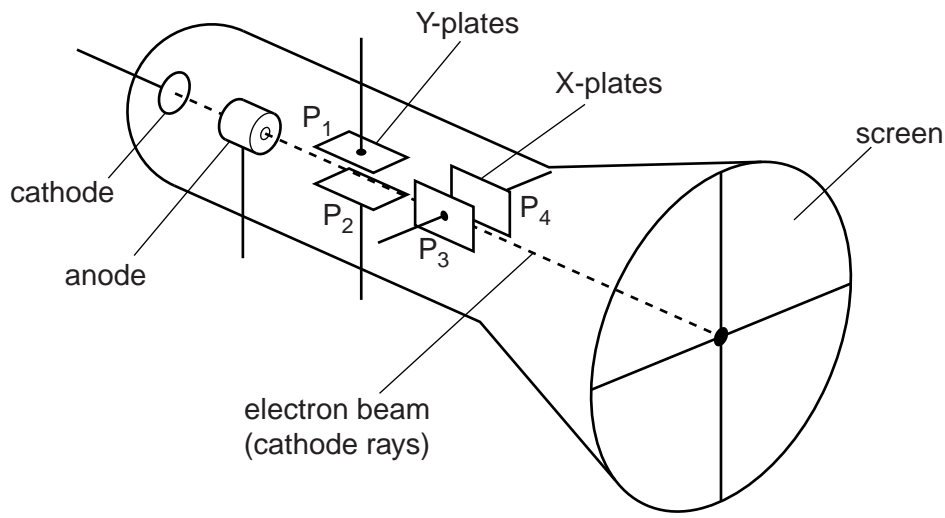

Fig. 12.1

(a) What occupies the remaining space within the tube? Tick one box.

- air
- hydrogen
- nitrogen
- vacuum

[1]

(b) How does the screen show the presence of electrons?

.....  
..... [2]

(c) What is done to the cathode to make it release electrons?

.....  
..... [1]

(d) Between which two parts shown on Fig. 12.1 is there a large potential difference that causes the electrons to be accelerated into a beam?

..... and ..... [2]

(e) The electron beam normally travels along the axis of the tube, as shown in Fig. 12.1. Between which two parts must a potential difference be connected in order to deflect the beam upwards?

..... [1]

[Total: 7]

