



UNIVERSITY OF CAMBRIDGE INTERNATIONAL EXAMINATIONS
International General Certificate of Secondary Education

CANDIDATE
NAME

CENTRE
NUMBER

--	--	--	--	--

CANDIDATE
NUMBER

--	--	--	--



PHYSICS

0625/62

Paper 6 Alternative to Practical

October/November 2012

1 hour

Candidates answer on the Question Paper.
No Additional Materials are required.

READ THESE INSTRUCTIONS FIRST

Write your Centre number, candidate number and name on all the work you hand in.
Write in dark blue or black pen.
You may use a pencil for any diagrams or graphs.
Do not use staples, paper clips, highlighters, glue or correction fluid.
DO NOT WRITE IN ANY BARCODES.

Answer **all** questions.

At the end of the examination, fasten all your work securely together.
The number of marks is given in brackets [] at the end of each question or part question.

For Examiner's Use	
1	
2	
3	
4	
5	
Total	

This document consists of **12** printed pages.



2

- 1 The IGCSE class is carrying out refraction experiments using a rectangular glass block and optical pins.
- (a) In the middle of the space below, draw a line, 10 cm long, across the page and label it **AB**. This line represents one side of the glass block.

[1]

- (b) Draw a normal to this line at the centre of **AB**. [1]

- (c) Draw a line at 30° to the normal to represent an incident ray. This line should be at least 6 cm long. Label this line **EF**. [1]

- (d) Mark the positions of two pins P_1 and P_2 on line **EF**. They should be positioned at suitable places on the line in order to carry out a ray-tracing experiment as accurately as possible. [1]

3

- (e) A student finds that his completed results from the refraction experiment do not match the theory. The student carried out the experiment correctly and with reasonable care.

Suggest a practical reason why the results could differ slightly from the results expected from the theory.

.....

.....

..... [1]

[Total: 5]

2 An IGCSE class is investigating the rate of cooling of water.

The apparatus is shown in Fig. 2.1.

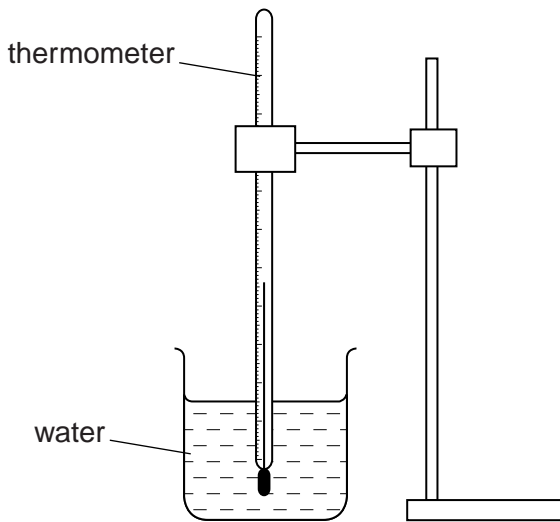

Fig. 2.1

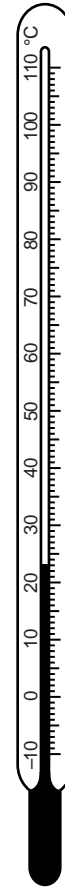

Fig. 2.2

(a) Record room temperature θ_R as shown on the thermometer in Fig. 2.2.

$\theta_R = \dots\dots\dots [2]$

(b) A student pours 200 cm^3 of hot water into a beaker. She records the temperature θ_0 of the water.

$\theta_0 = \dots\dots\dots 86^\circ\text{C} \dots\dots\dots$

She starts a stopclock and records the temperature θ_1 of the water at time $t = 100\text{ s}$.

$\theta_1 = \dots\dots\dots 72^\circ\text{C} \dots\dots\dots$

(i) Calculate the temperature difference θ_A between θ_0 and room temperature θ_R using the equation $\theta_A = (\theta_0 - \theta_R)$.

$\theta_A = \dots\dots\dots$

(ii) Calculate the temperature fall θ_H of the hot water using the equation $\theta_H = (\theta_0 - \theta_1)$.

$\theta_H = \dots\dots\dots$

- (c) The student empties the beaker. She pours 100 cm³ of hot water into the beaker and 100 cm³ of cold water to the beaker, and stirs.

She records the temperature θ_2 of the warm water.

$$\theta_2 = \dots\dots\dots 59^\circ\text{C}$$

She starts the stopclock and records the temperature θ_3 of the water at time $t = 100$ s.

$$\theta_3 = \dots\dots\dots 44^\circ\text{C}$$

- (i) Calculate the temperature difference θ_B between θ_2 and room temperature θ_R using the equation $\theta_B = (\theta_2 - \theta_R)$.

$$\theta_B = \dots\dots\dots$$

- (ii) Calculate the temperature fall θ_W of the warm water using the equation $\theta_W = (\theta_2 - \theta_3)$.

$$\theta_W = \dots\dots\dots$$

[1]

- (d) The student suggests that the rate of temperature change is proportional to the difference between the starting temperature and room temperature. This can be expressed as

$$\frac{\theta_A}{\theta_H} = \frac{\theta_B}{\theta_W}$$

State whether the results support this suggestion and justify your answer with reference to the results.

statement

justification

.....

[2]

- (e) If this experiment were to be repeated in order to check results, it would be important to control the conditions.

Suggest two such conditions that should be controlled.

1.

2.

[2]

[Total: 8]

- 3 The IGCSE class is investigating current and potential difference using identical lamps in a circuit.

The circuit is shown in Fig. 3.1.

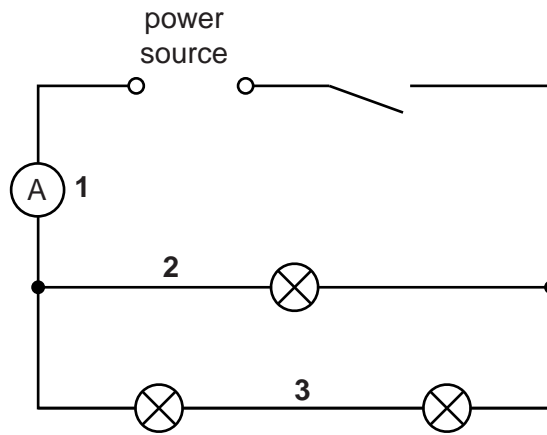

Fig. 3.1

- (a) On Fig. 3.1, draw the symbol for a voltmeter connected to measure the potential difference V across the combination of lamps. [1]
- (b) On Fig. 3.2, draw a pointer showing the voltmeter reading $V = 1.9V$.

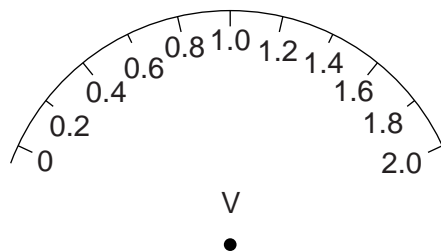

Fig. 3.2

[1]

- (c) (i) A student measures the current at positions 1, 2 and 3 in the circuit. Record the current at each position as shown on the ammeters in Fig. 3.3.

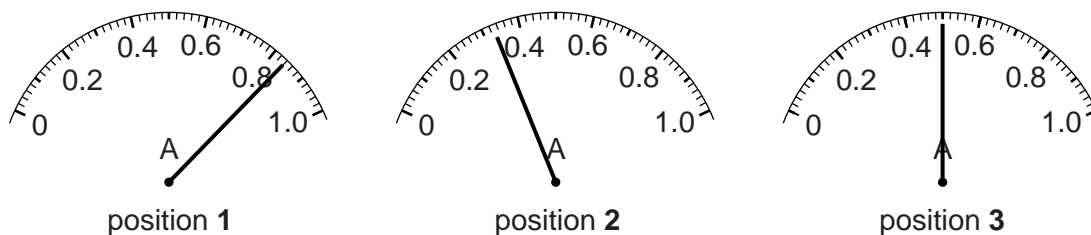

Fig. 3.3

$I_1 = \dots\dots\dots$

$I_2 = \dots\dots\dots$

$I_3 = \dots\dots\dots$

- (ii) Calculate the total current I_C in the combination of lamps using the equation $I_C = I_2 + I_3$.

$I_C =$

- (iii) Theory indicates that $I_1 = I_C$. Suggest why a student may find the two values to be different in this experiment.

.....

.....

..... [1]

- (d) The student decides to investigate the effect of changing the current I_1 , using a variable resistor (rheostat).

In the space below, copy the diagram shown in Fig. 3.1, but with the addition of a variable resistor connected at a suitable position for the investigation.

[2]

- (e) A student sets up the circuit as shown in Fig. 3.1. Neither of the two lamps in series glows. He suspects that one of the lamps is faulty.

Suggest how the apparatus may be used to find out which lamp is faulty.

.....

..... [1]

[Total: 7]

- 4 The IGCSE class is determining the focal length of a lens.

The apparatus is shown in Fig. 4.1.

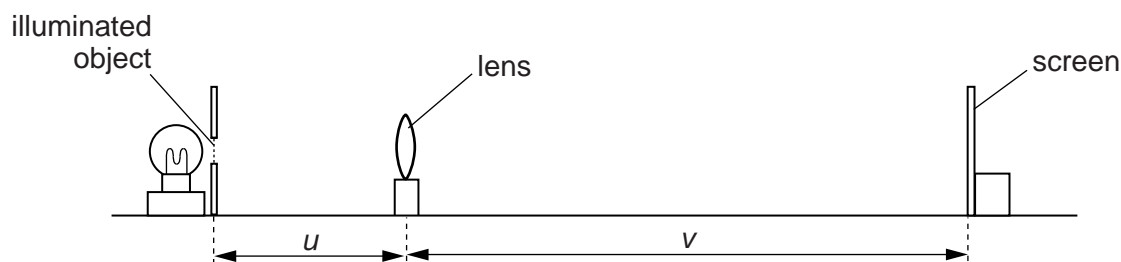

Fig. 4.1

A student places a lens at a distance $u = 30.0$ cm from an illuminated object. She moves the screen until a sharply focused image of the object is seen on the screen.

She measures the distance v between the centre of the lens and the screen. She calculates d , using the equation $d = u + v$.

She repeats the procedure using a range of values of u . The values of u , v and d are shown in Table 4.1.

Table 4.1

u/cm	v/cm	$uv/$	$d/$
30.0	29.8		59.8
45.0	22.0		67.0
50.0	21.8		71.8
55.0	21.0		76.0
60.0	19.9		79.9

- (a) (i) Calculate the value of uv for each set of readings and enter the values in the table.
(ii) Complete the column headings in the table by inserting the units for uv and d .

[2]

- (b) Complete the labelling of the axes below, and plot the graph using data from the table. You do **not** need to begin the axes at the origin (0,0).

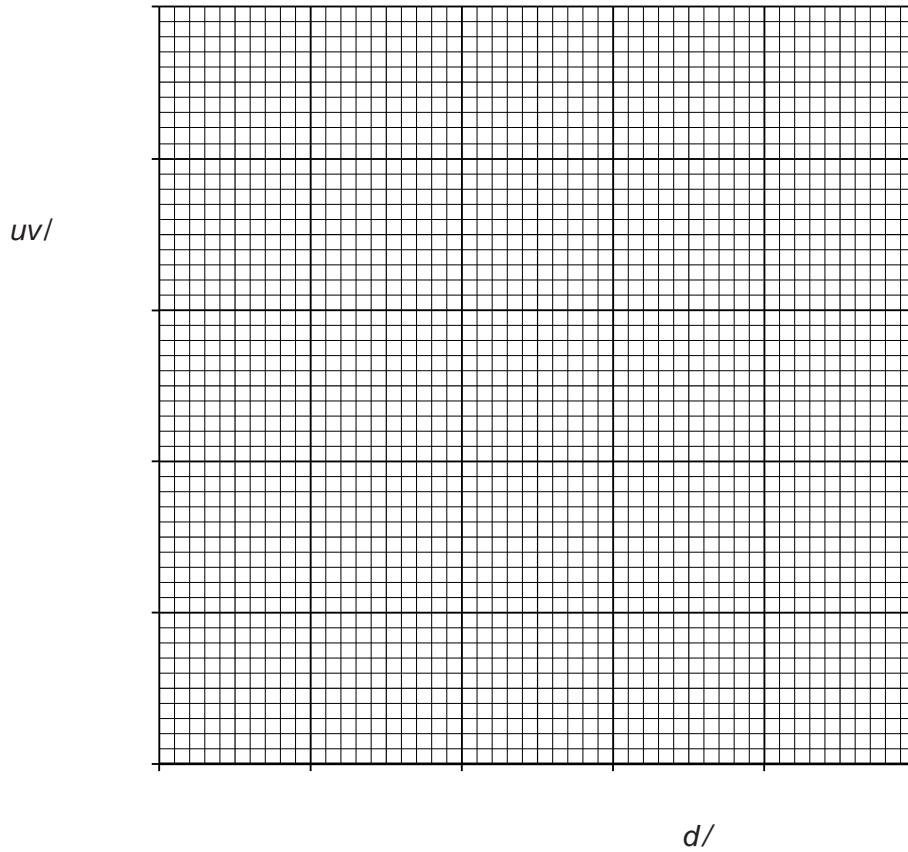

[4]

- (c) The gradient of the graph is numerically equal to the focal length of the lens.
- (i) Determine the gradient G of the graph. Show clearly on the graph how you obtained the necessary information.

$G = \dots\dots\dots$ [2]

- (ii) State a value for the focal length f of the lens, giving your answer to a suitable number of significant figures for this experiment.

$f = \dots\dots\dots$ [2]

[Total: 10]

5 The IGCSE class is investigating a pendulum.

The apparatus is shown in Fig. 5.1.

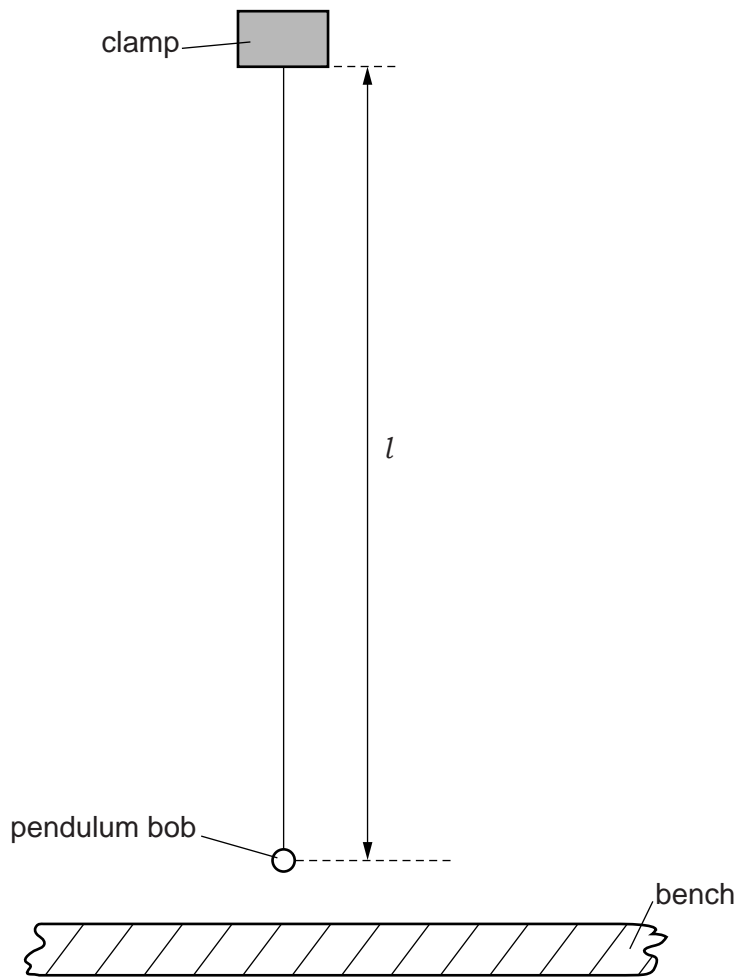

Fig. 5.1

(a) On Fig. 5.1, measure the length l of the pendulum.

$l = \dots\dots\dots$ [1]

(b) The diagram is drawn $1/5^{\text{th}}$ actual size.

Calculate the actual length L of the pendulum.

$L = \dots\dots\dots$ [2]

- (c) A student places a metre rule on the bench so that the 50.0 cm mark is vertically above the centre of the pendulum bob. Describe how you would judge that the 50.0 cm mark is vertically below the centre of the pendulum bob. You may draw a diagram.

.....
 [1]

- (d) The student pulls the pendulum bob to one side until it is vertically above the 52.0 cm mark on the rule. He has moved the pendulum bob a horizontal distance $d = 2.0$ cm.

He releases the pendulum bob, then measures the time t taken for 12 complete swings of the pendulum. He repeats the procedure using a range of d values. The values of d and t are shown in Table 5.1.

Table 5.1

$d/$	$t/$	$T/$
2.0	17.4	
3.0	17.6	
4.0	17.2	
5.0	17.3	
6.0	17.5	

- (i) Calculate the period T of the pendulum for each value of d . Enter the values in the table. The period T is the time taken for one complete swing of the pendulum. [2]
- (ii) Complete the column headings in the table. [1]
- (e) Using the evidence in the table, describe the effect on the period T of increasing the distance d . Justify your answer by reference to your results.

description

.....

justification

.....

.....

[2]

(f) Suggest why the student measures the time taken for twelve swings of the pendulum rather than for one swing.

.....

.....

..... [1]

[Total: 10

Permission to reproduce items where third-party owned material protected by copyright is included has been sought and cleared where possible. Every reasonable effort has been made by the publisher (UCLES) to trace copyright holders, but if any items requiring clearance have unwittingly been included, the publisher will be pleased to make amends at the earliest possible opportunity.