



UNIVERSITY OF CAMBRIDGE INTERNATIONAL EXAMINATIONS  
International General Certificate of Secondary Education

CANDIDATE  
NAME

CENTRE  
NUMBER

--	--	--	--	--

CANDIDATE  
NUMBER

--	--	--	--



**PHYSICS**

**0625/63**

Paper 6 Alternative to Practical

**October/November 2012**

**1 hour**

Candidates answer on the Question Paper.  
No Additional Materials are required.

**READ THESE INSTRUCTIONS FIRST**

Write your Centre number, candidate number and name on all the work you hand in.  
Write in dark blue or black pen.  
You may use a pencil for any diagrams or graphs.  
Do not use staples, paper clips, highlighters, glue or correction fluid.  
**DO NOT WRITE IN ANY BARCODES.**

Answer **all** questions.

At the end of the examination, fasten all your work securely together.  
The number of marks is given in brackets [ ] at the end of each question or part question.

For Examiner's Use	
1	
2	
3	
4	
5	
<b>Total</b>	

This document consists of **14** printed pages and **2** blank pages.



1 An IGCSE class is carrying out this experiment to determine the mass of a metal block

Fig. 1.1 shows a spring drawn full size.

Fig. 1.2, also full size, shows the spring with a load of 100 g suspended from it.

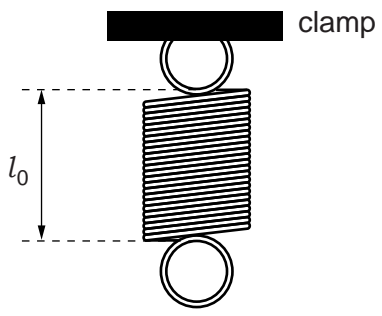

Fig. 1.1

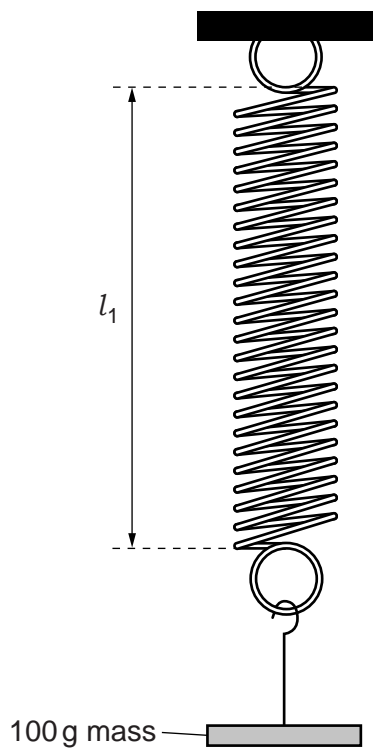

Fig. 1.2

(a) (i) On Fig. 1.1, measure the length  $l_0$ , in cm, of the spring without any load.

$l_0 = \dots\dots\dots$  cm

(ii) On Fig. 1.2 measure the stretched length  $l_1$ , in cm.

$l_1 = \dots\dots\dots$  cm  
[1]

(iii) Calculate the extension  $e_1$  of the spring using the equation  $e_1 = (l_1 - l_0)$ .

$e_1 = \dots\dots\dots$  [1]

(iv) Determine a value for  $k$  using the equation  $k = \frac{m}{e_1}$ , where  $m = 100$  g.

$k = \dots\dots\dots$  unit  $\dots\dots\dots$  [2]

(b) The apparatus is then set up as shown in Fig. 1.3. The rule is at a small angle to the bench.

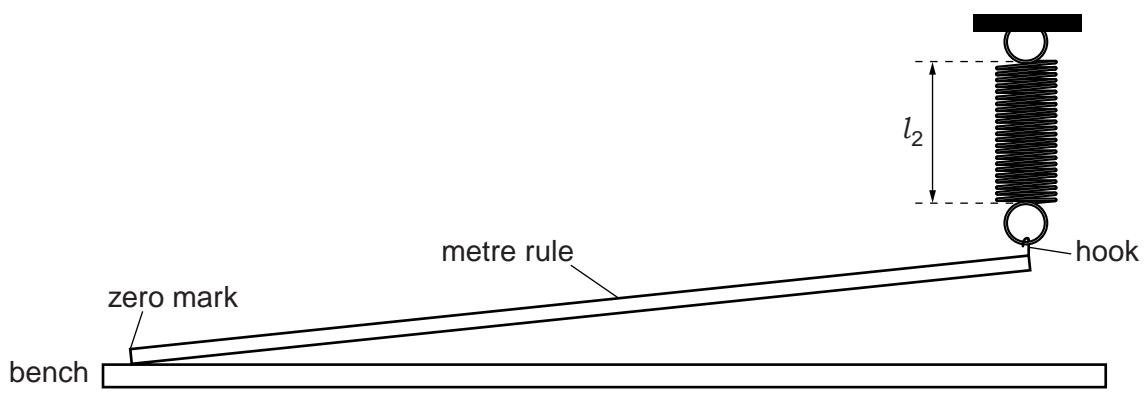

Fig. 1.3

A student measures the length of the stretched spring and obtains the result

$l_2 = \dots\dots\dots 4.4 \text{ cm}$

(i) He then places a metal block X with its centre at the 40.0 cm mark on the rule.

Explain briefly how the student can make sure that the block is in the correct position. You may wish to use a diagram.

.....  
.....  
..... [1]

(ii) The student measures the new length  $l_3$  of the spring and records it as

$l_3 = \dots\dots\dots 7.5 \text{ cm}$

Determine the change in the extension  $e_2$  due to block X, using the equation  $e_2 = (l_3 - l_2)$ .

$e_2 = \dots\dots\dots$

(iii) Calculate the mass  $M$  of block X using your answers to (a)(iv) and (b)(ii) and the equation  $M = k \left( \frac{e_2}{0.40} \right)$ .

$M = \dots\dots\dots$  [2]

(c) Suggest two practical causes of inaccuracy in this experiment.

1. ....

.....

2. ....

.....

[2]

[Total: 9]



- 2 Some IGCSE students have been asked to investigate how different surfaces absorb radiation.

The apparatus is set up as shown in Fig. 2.1, with a piece of white card in close contact with the thermometer bulb.

The distance between the card and the lamp is 1.0 cm.

Fig. 2.1 shows the reading on the thermometer before the lamp is switched on.

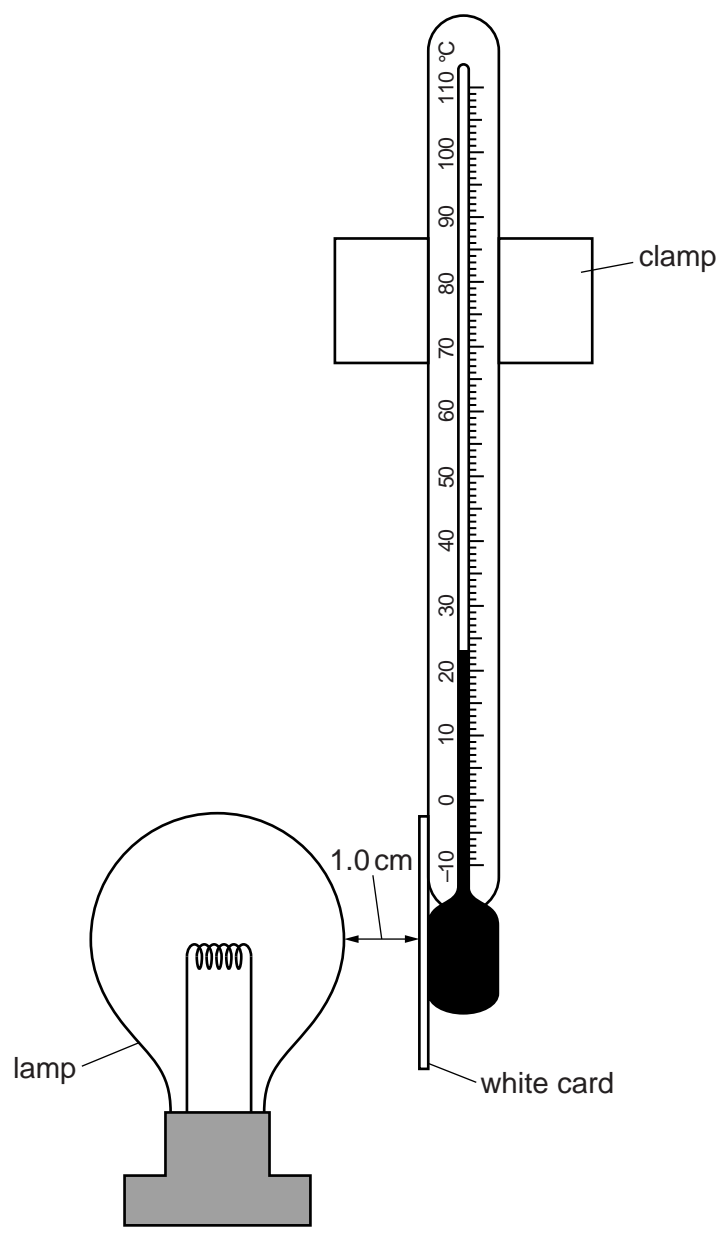

Fig. 2.1

- (a) In Table 2.1, record the temperature before the lamp is switched on, as shown in Fig. 2.1.
- (b) The lamp is switched on and the temperature recorded every minute.

After 300s, the lamp is switched off and the white card is replaced with a piece of black card.

The lamp is then switched on for a further 300s, and the temperature recorded every

Table 2.1 shows the readings obtained during the experiment.

(i) Complete the column headings in the table.

**Table 2.1**

	white card	black card
<i>t</i> /	<i>θ</i> /	<i>θ</i> /
0		24
60	25	30
120	28	37
180	30	42
240	32	45
300	33	47

[2]

(ii) Calculate the overall temperature change for each card after 300 s.

white card: temperature change = .....

black card: temperature change = .....

[1]

(iii) Determine which surface, white or black, absorbs thermal radiation more efficiently. State the experimental evidence for your choice.

surface.....

evidence .....

.....

[1]

(iv) A student suggests that the rate of temperature rise will be greater at the beginning of the experiment than towards the end of the experiment.

State whether the results support this. Justify your answer with reference to the data for black card.

statement .....

justification .....

.....

.....

[2]

(c) Another IGCSE student wants to repeat the experiment.

Suggest one precaution which she should take with the apparatus to make the comparison between white and black surfaces a fair one. Explain why not taking this precaution might cause the test to be unfair.

precaution .....

explanation .....

.....

.....

[2]

[Total: 8]





3 The IGCSE class is investigating the resistance of a lamp.

The apparatus has been set out as shown in Fig. 3.1.

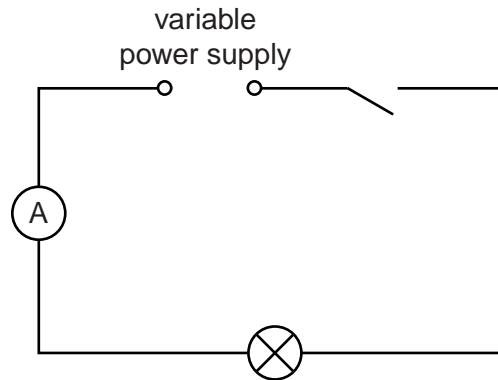

**Fig. 3.1**

- (a) On Fig. 3.1, draw the symbol for a voltmeter correctly connected to measure the potential difference across the lamp. [2]
- (b) Table 3.1 shows the values of potential difference  $V$  and current  $I$  obtained during the experiment, and observations regarding the lamp.

**Table 3.1**

$V/$	$I/$	$R/$	observation
1.5	0.15		lamp is just glowing
3.2	0.23		lamp is lit but is dim
4.7	0.26		lamp is brighter
6.5	0.31		lamp is very bright

[3]

- (i) Complete the column headings in Table 3.1.
- (ii) Calculate, and record in the table, the resistance  $R$  of the lamp at each potential difference  $V$  using the equation  $R = \frac{V}{I}$ .

(c) A student suggests that the resistance of a lamp stays the same whatever its temperature.

State whether the results support this idea. Justify your answer, using the results and the observations obtained during the experiment.

statement .....

.....

justification .....

.....

.....

.....

[3]

[Total: 8]

4 An IGCSE class is carrying out an experiment to determine the focal length of a convex lens.

The apparatus is set up as shown in Fig. 4.1.

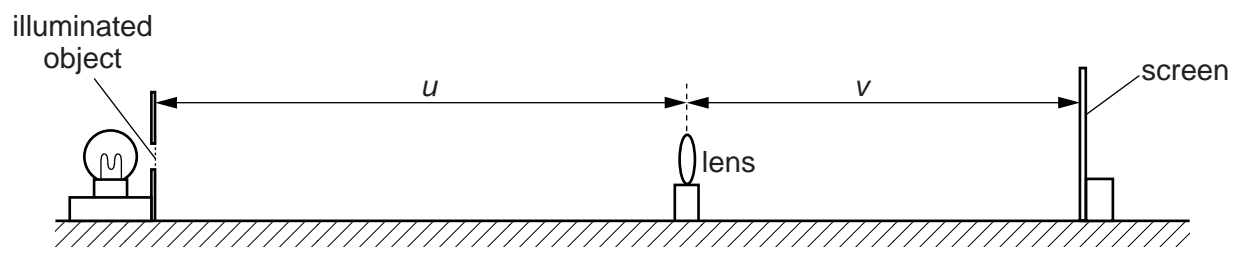

Fig. 4.1

(a) The object distance  $u$  is set and a sharp image is obtained on the screen.

(i) Measure the object distance  $u$  on Fig. 4.1.

$u = \dots\dots\dots$

(ii) Measure the image distance  $v$  on Fig. 4.1.

$v = \dots\dots\dots$

[1]

(iii) The diagram is drawn to  $\frac{1}{5}$ <sup>th</sup> full size. Determine the actual values, in metres, of  $u$  and  $v$ . Record these values in Table 4.1.

(b) Four more object distances are set up and these and the corresponding image distances are recorded in Table 4.1.

Complete the table by calculating values of  $\frac{1}{u}$  and  $\frac{1}{v}$  as necessary.

Table 4.1

$u / \text{m}$	$\frac{1}{u} / \frac{1}{\text{m}}$	$v / \text{m}$	$\frac{1}{v} / \frac{1}{\text{m}}$
0.200	5.00	0.600	
0.250	4.00	0.392	
0.450	2.22	0.222	
0.600	1.67	0.196	

[2]

- (c) Plot a graph of  $\frac{1}{v} / \frac{1}{m}$  (y-axis) against  $\frac{1}{u} / \frac{1}{m}$  (x-axis). Begin both axes at the origin. The scale must allow the best-fit line, when extended beyond the range of the data, to cross both axes.

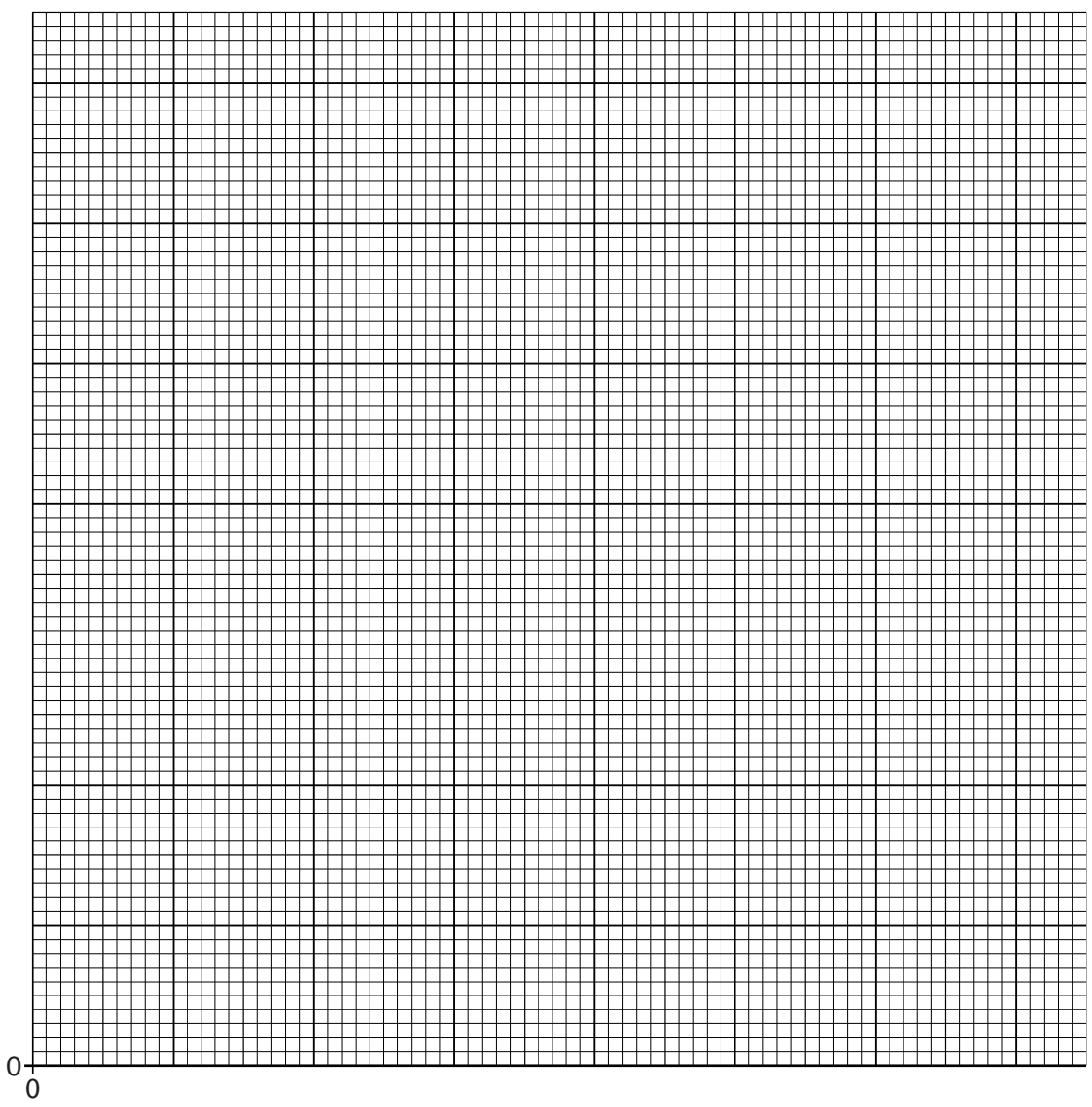

[4]

- (d) (i) From the graph, determine the value  $p$  of  $\frac{1}{u}$  when  $\frac{1}{v}$  is zero (the x-intercept).

$p = \dots\dots\dots$

- (ii) From the graph, determine the value  $q$  of  $\frac{1}{v}$  when  $\frac{1}{u}$  is zero (the y-intercept).

$q = \dots\dots\dots$  [1]

14

(e) (i) Calculate  $z$ , where  $z$  is the average value of  $p$  and  $q$ .

$z = \dots\dots\dots$

(ii) Calculate the focal length  $f$  of the lens where  $f = \frac{1}{z}$ .

$f = \dots\dots\dots$

[2]

[Total: 10]

- 5 Some IGCSE students are carrying out an experiment to investigate how a tennis ball bounces on various surfaces.

Fig. 5.1 shows how they are doing this. The ball is dropped from a known height and the height of the bounce is measured.

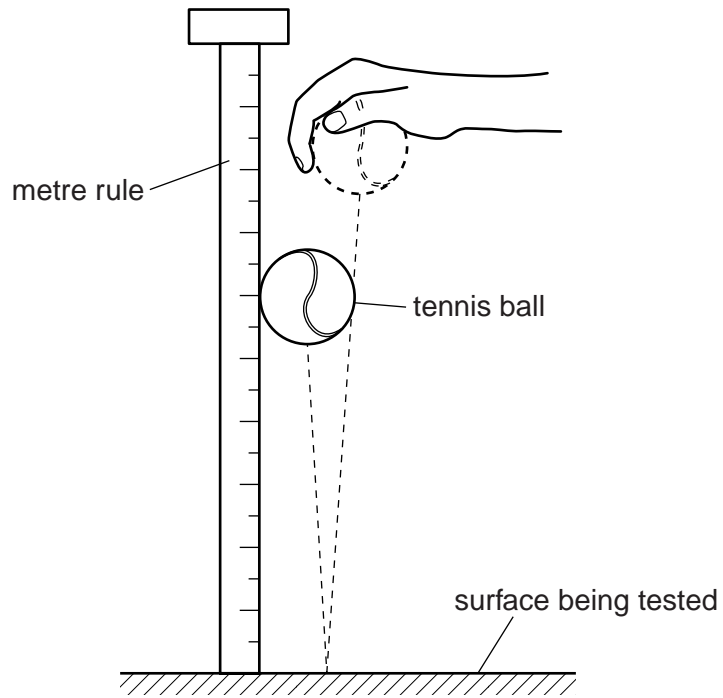

Fig. 5.1

- (a) One student drops the ball several times from a height of 100 cm. Each time he measures the height to which the ball bounces. His measurements are shown in Table 5.1.

Table 5.1

test	1	2	3	4	5
height of bounce/cm	74	70	72	53	69

Explain how a valid average value for the height of the bounce could be achieved from these results. You are not asked to calculate it.

.....

.....

..... [2]

- (b) Another student releases the ball from a height of 100 cm on to a stone floor. It bounces to a height of 75 cm.

Calculate the efficiency of the bounce on the stone floor using the equation

$$\text{efficiency} = \frac{\text{height of bounce}}{\text{height of release}} \times 100\%.$$

efficiency = .....[1]

- (c) A third student releases the ball from a height of 85 cm on to a concrete floor and it bounces to a height of 75 cm.

Without any further calculation, state whether the efficiency for the concrete floor is less than, greater than, or roughly the same as the efficiency for the stone floor. Explain your reasoning.

statement.....

.....

explanation .....

.....

.....

[2]

[Total: 5]