



UNIVERSITY OF CAMBRIDGE INTERNATIONAL EXAMINATIONS
International General Certificate of Secondary Education

PHYSICS**0625/11**

Paper 1 Multiple Choice

May/June 2013**45 minutes**

Additional Materials: Multiple Choice Answer Sheet
 Soft clean eraser
 Soft pencil (type B or HB recommended)

READ THESE INSTRUCTIONS FIRST

Write in soft pencil.

Do not use staples, paper clips, highlighters, glue or correction fluid.

Write your name, Centre number and candidate number on the Answer Sheet in the spaces provided unless this has been done for you.

DO NOT WRITE IN ANY BARCODES.There are **forty** questions on this paper. Answer **all** questions. For each question there are four possible answers **A, B, C** and **D**.Choose the **one** you consider correct and record your choice in **soft pencil** on the separate Answer Sheet.**Read the instructions on the Answer Sheet very carefully.**

Each correct answer will score one mark. A mark will not be deducted for a wrong answer.

Any rough working should be done in this booklet.

Electronic calculators may be used.

This document consists of **20** printed pages.



1 The diagrams show the readings on a measuring cylinder before and after a small metal cube is added.

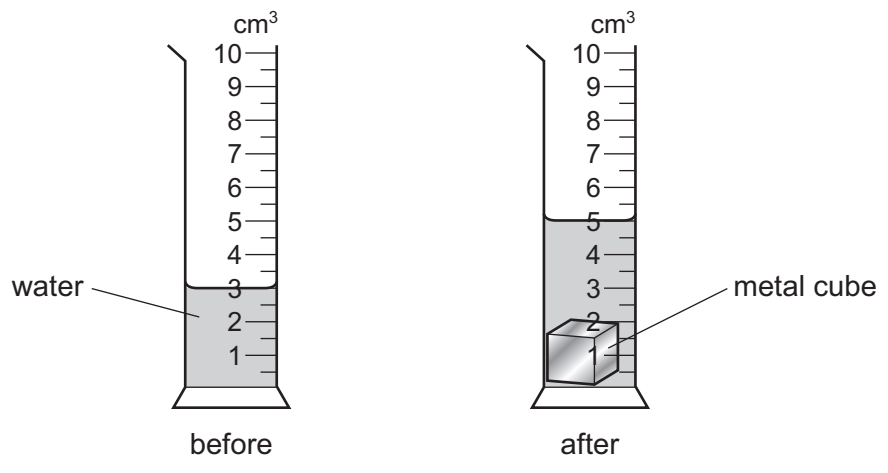

How many more identical cubes can be added to the cylinder, without causing the water to overflow? Do not include the cube already in the cylinder.

- A** 1 **B** 2 **C** 3 **D** 4

2 Which person is experiencing an acceleration?

- A** a driver of a car that is braking to stop at traffic lights
- B** a passenger in a train that is stationary in a railway station
- C** a shopper in a large store ascending an escalator (moving stairs) at a uniform rate
- D** a skydiver falling at constant speed towards the Earth

3 A car travels at various speeds during a short journey.

The table shows the distances travelled and the times taken during each of four stages P, Q, R and S.

stage	P	Q	R	S
distance travelled / km	1.8	3.6	2.7	2.7
time taken / minutes	2	2	4	3

During which two stages is the car travelling at the same average speed?

- A** P and Q **B** P and S **C** Q and R **D** R and S

3

- 4 Two blocks of metal X and Y hang from spring balances, as shown in the diagrams.

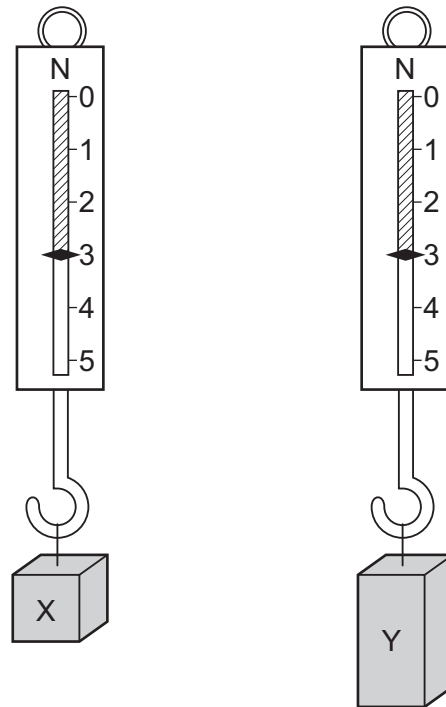

What does the diagram show about X and Y?

- A** They have the same mass and the same volume but different weights.
B They have the same mass and the same weight but different volumes.
C They have the same mass, the same volume and the same weight.
D They have the same weight and the same volume but different masses.
- 5 A 1 kg sample of aluminium is stored in a laboratory. In a different laboratory, in the same town, there is a 1 kg sample of iron.

Which quantity must these two samples **always** have in common?

- A** the same density
B the same temperature
C the same volume
D the same weight

6 A measuring cylinder has a mass of 120 g when empty.

When it contains 50 cm³ of a liquid, the total mass of the measuring cylinder and the liquid is 160 g.

What is the density of the liquid?

- A $\frac{40}{50}$ g/cm³
- B $\frac{50}{40}$ g/cm³
- C $\frac{120}{50}$ g/cm³
- D $\frac{160}{50}$ g/cm³

7 A car moves along a level road.

The diagram shows all of the horizontal forces acting on the car.

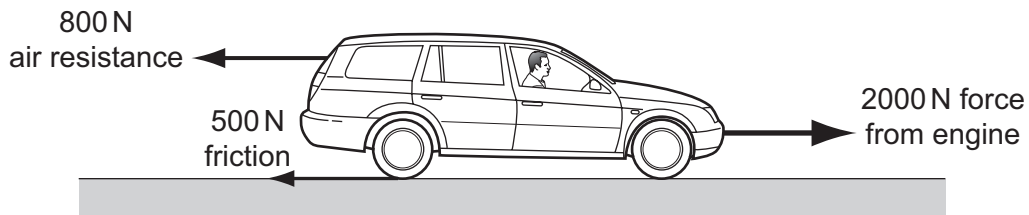

Which statement is correct?

- A The car is slowing down.
- B The car is speeding up.
- C The car is moving at a constant speed.
- D The car is moving backwards.

- 8 The diagram shows a force being applied to a lever to lift a heavy weight.

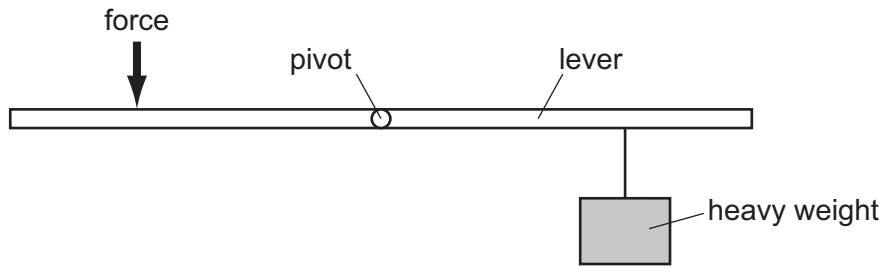

Which change would enable the heavy weight to be lifted with a smaller force?

- A Move the force to the right.
 - B Move the heavy weight to the right.
 - C Move the force to the left.
 - D Move the pivot to the left.
- 9 The diagram shows a hydroelectric system.

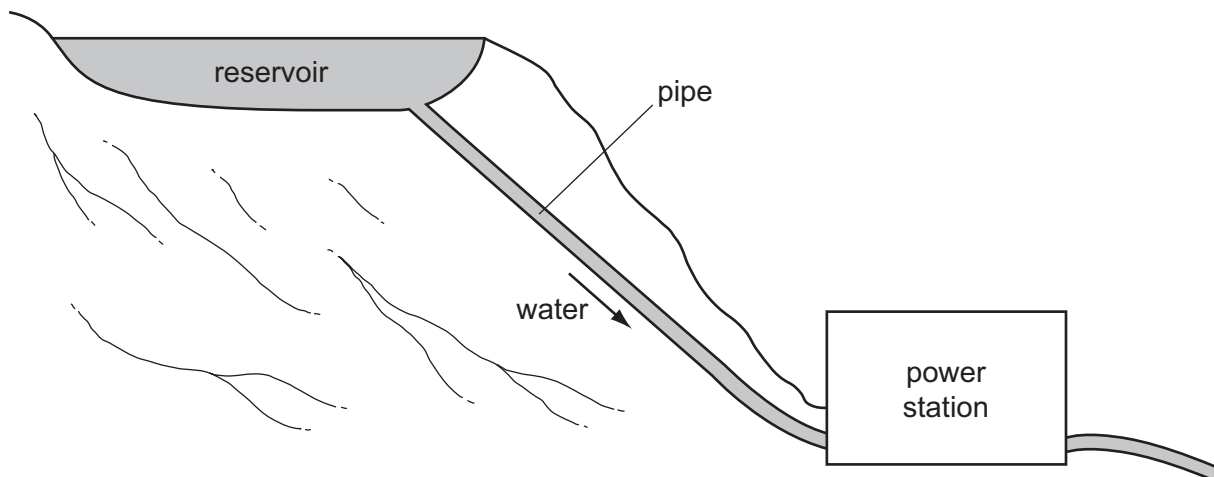

What are the main energy changes taking place?

- A chemical energy → kinetic energy → electrical energy
- B electrical energy → gravitational energy → kinetic energy
- C gravitational energy → kinetic energy → electrical energy
- D kinetic energy → electrical energy → gravitational energy

6

- 10 An escalator (moving stairs) and a lift (elevator) are both used to carry passengers from an underground railway platform up to street level.

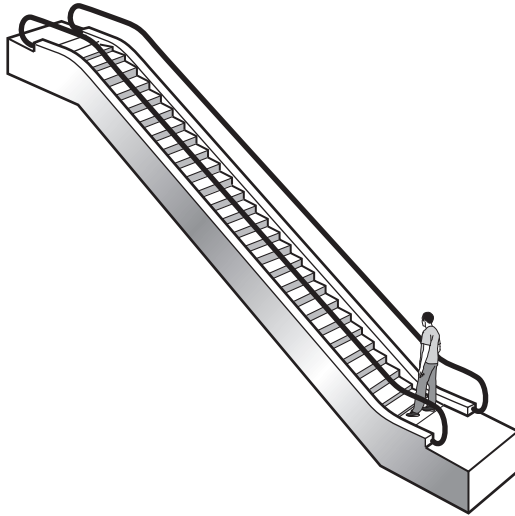

escalator

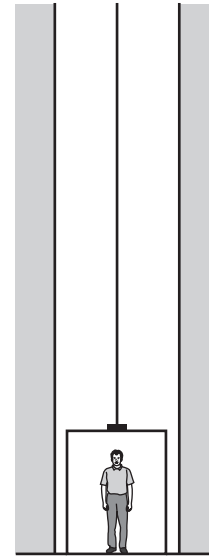

lift

The escalator takes 20 seconds to carry a man to street level. The useful work done is W . The useful power developed is P . The lift takes 30 seconds to carry the same man to street level.

How much useful work is done by the lift, and how much useful power is developed by the lift?

	useful work done by lift	useful power developed by lift
A	more than W	less than P
B	more than W	P
C	W	less than P
D	W	P

- 11 A man stands on the ground.

Which action will increase the pressure that the man exerts on the ground?

- A** The man slowly bends his knees.
- B** The man slowly lies down on the ground.
- C** The man slowly raises his arms.
- D** The man slowly raises one foot off the ground.

12 The diagram shows a simple mercury barometer.

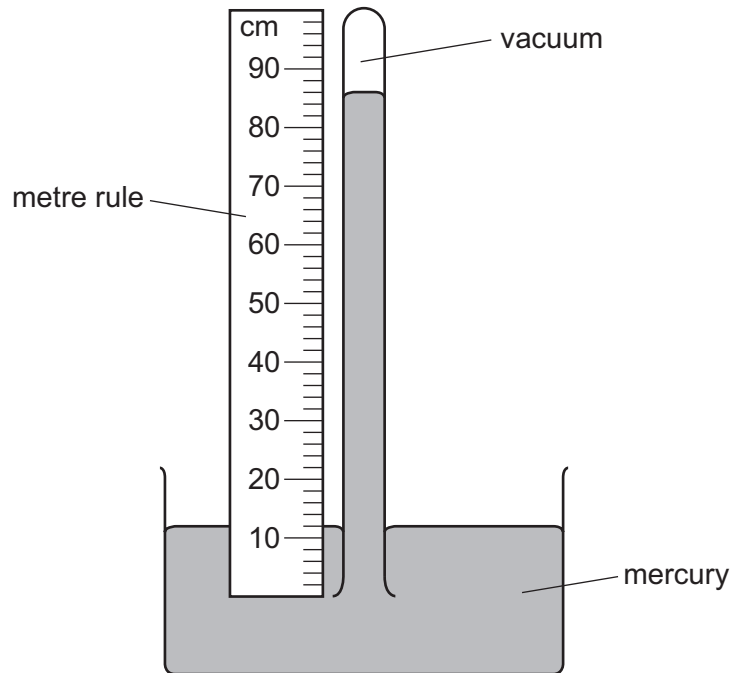

Which length is used to find the value of atmospheric pressure?

- A** 12 cm **B** 74 cm **C** 86 cm **D** 100 cm

13 A thermometer bulb is covered by a piece of damp absorbent cloth.

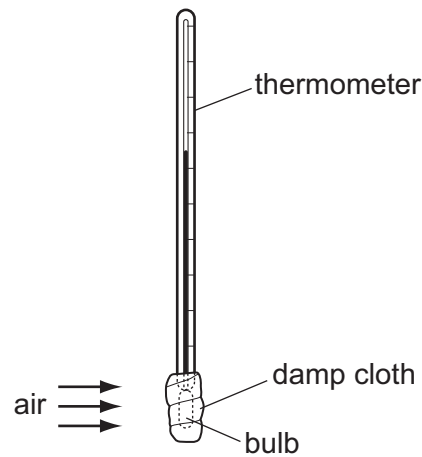

Air at room temperature is blown across the damp cloth.

What happens to the thermometer reading?

- A** It remains constant.
B It rises.
C It rises then falls.
D It falls.

14 A gas storage tank has a fixed volume. The graph shows how the temperature of the tank varies with time.

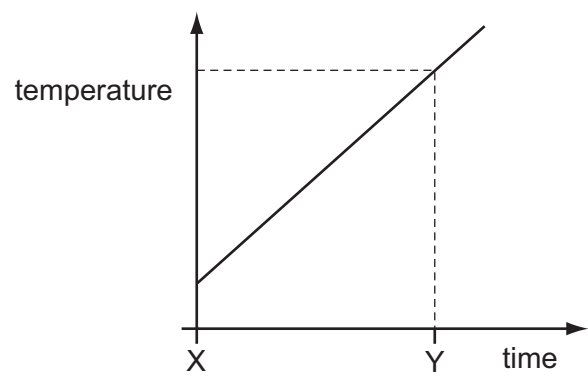

At time Y, the gas molecules are

- A closer together than at time X.
- B hitting the sides of the tank harder than at time X.
- C larger in size than at time X.
- D moving more slowly than at time X.

15 The diagrams show four blocks of steel. The blocks are all drawn to the same scale.

The same quantity of thermal energy (heat) is given to each block.

Which block shows the greatest rise in temperature?

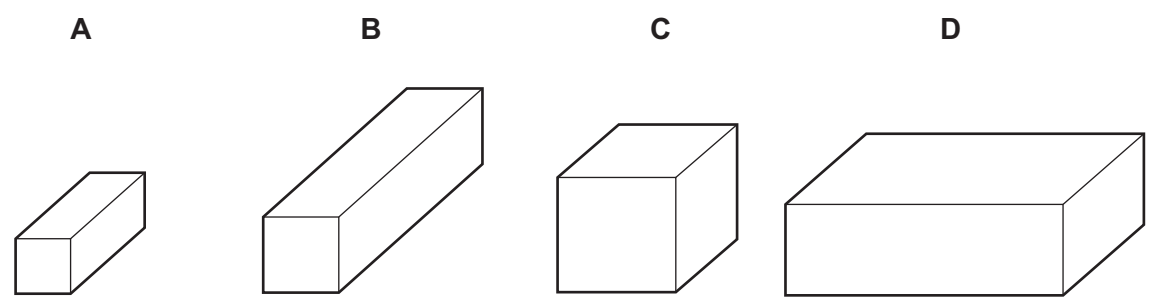

16 A mercury thermometer with no scale is taped to a ruler as shown.

When the thermometer is placed in steam, the mercury level rises to 22.0 cm.

When the thermometer is placed in pure melting ice, the mercury level falls to 2.0 cm.

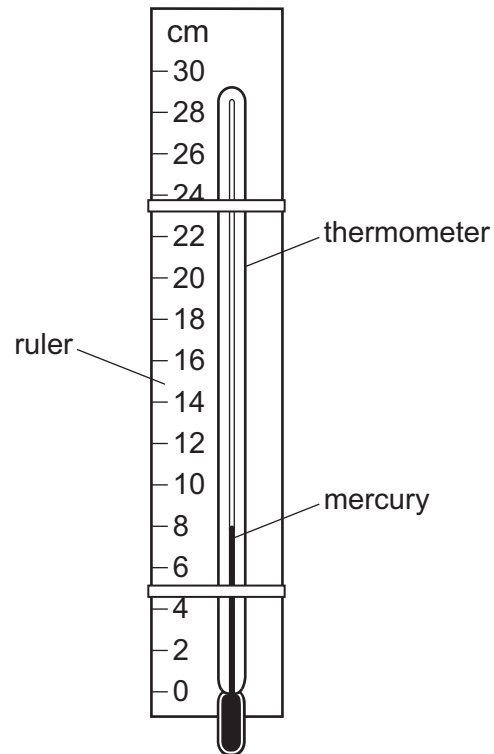

Which temperature is shown by the mercury level in the diagram?

- A** 6°C **B** 8°C **C** 30°C **D** 40°C

- 17 The diagram shows the cross-section of a vacuum flask containing a hot liquid in a cold room. X and Y are points on the inside surfaces of the walls of the flask.

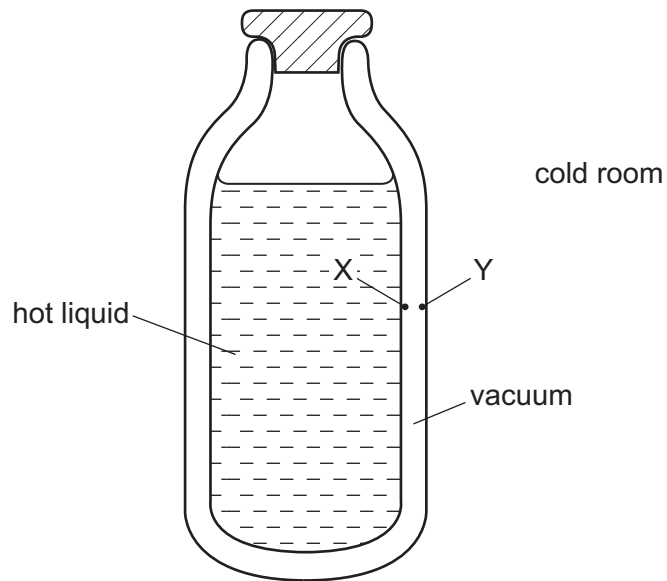

How is thermal energy transferred between X and Y?

- A by conduction and convection
- B by conduction only
- C by radiation and convection
- D by radiation only

18 The diagram shows a refrigerator.

The cooling unit is placed at the top. The cooling unit cools the air near it.

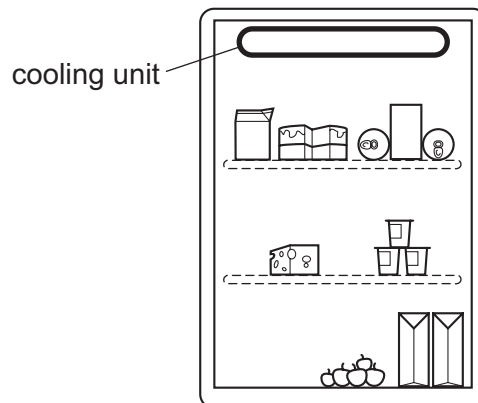

What happens to the density of the air as it cools, and how does it move?

	density of the air	movement of the air
A	decreases	moves down
B	decreases	stays at the top
C	increases	moves down
D	increases	stays at the top

19 Visible light and γ -rays are both waves.

How may they correctly be described?

	visible light	γ -rays
A	longitudinal	longitudinal
B	longitudinal	transverse
C	transverse	longitudinal
D	transverse	transverse

20 The diagram represents a wave.

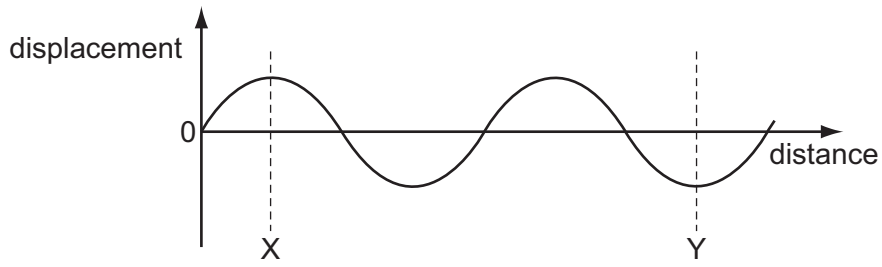

How many wavelengths are there between X and Y?

- A** $\frac{2}{3}$ **B** 1 **C** $1\frac{1}{2}$ **D** 3

21 Different parts of the electromagnetic spectrum are used for different purposes. Below are four statements about parts of the spectrum.

statement 1: Infra-red waves are used in television remote controllers.

statement 2: Radio waves are used to transmit television pictures from satellites to Earth.

statement 3: Ultra-violet waves are used for intruder alarms.

statement 4: X-rays are used for security checks.

Which statements are correct?

- A** 1 and 2 **B** 1 and 4 **C** 2 and 3 **D** 3 and 4

22 Which diagram shows how a ray of light could pass through a glass block in air?

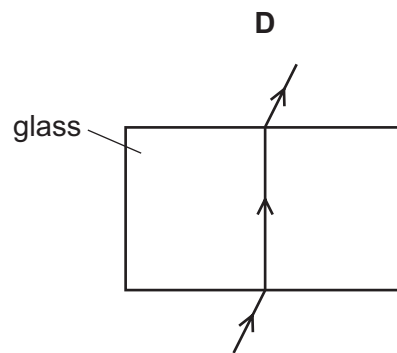
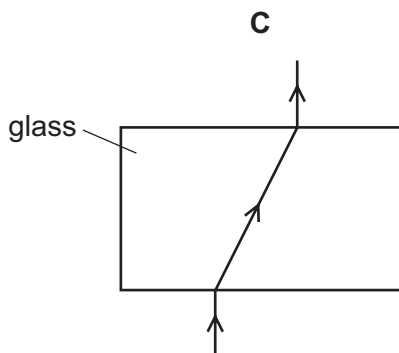
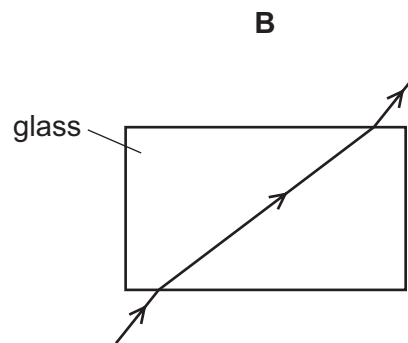
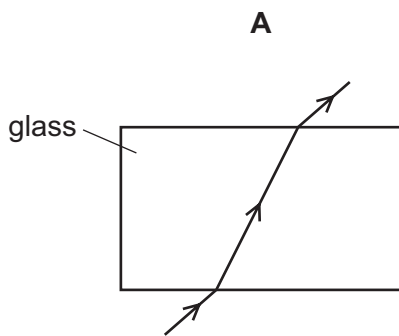

23 Which diagram correctly represents rays of light passing through a converging lens in a camera?

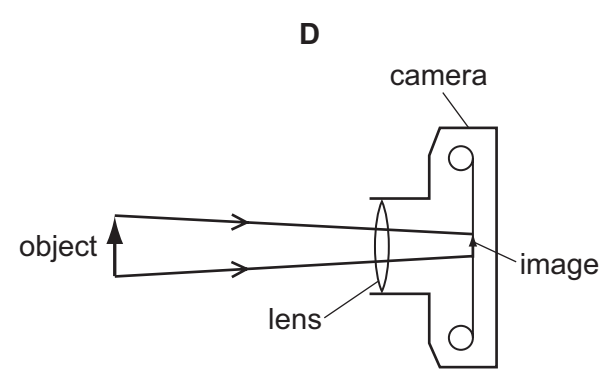
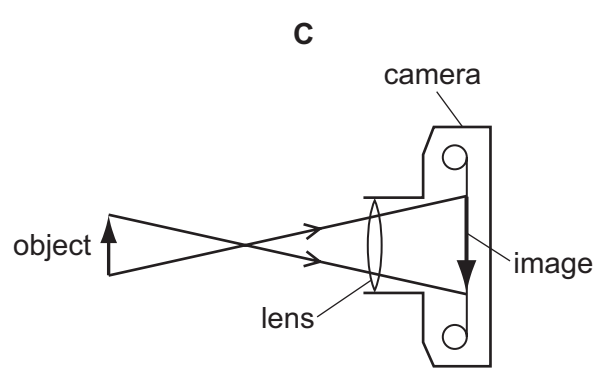
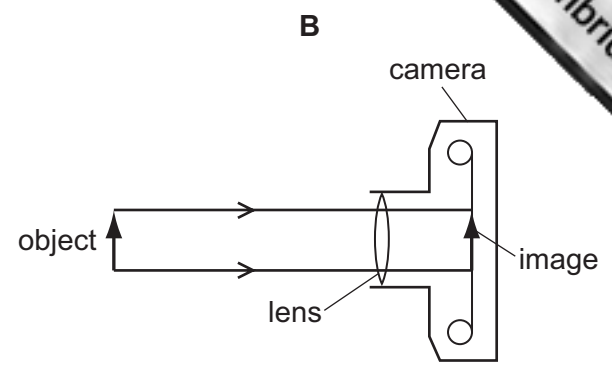
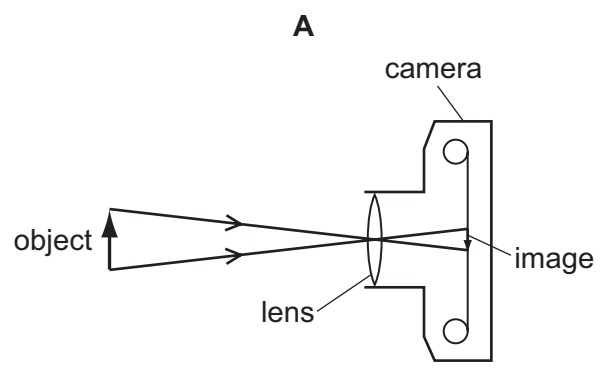

24 The diagrams represent two sound waves. The scales in the two diagrams are the same.

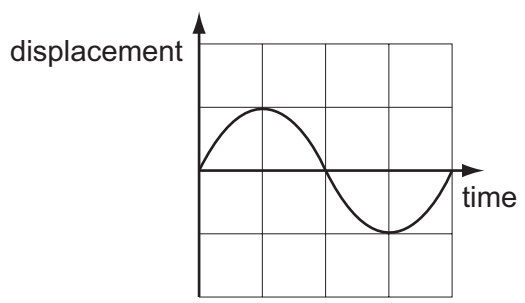

sound wave 1

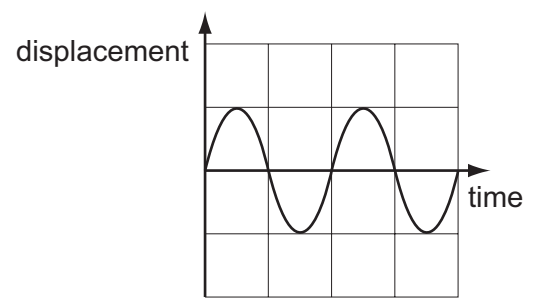

sound wave 2

Which statement describes the waves?

- A** The waves have different loudness and different pitch.
- B** The waves have different loudness but the same pitch.
- C** The waves have the same loudness and the same pitch.
- D** The waves have the same loudness but different pitch.

25 A student claps once when standing 100 m away from a large wall.

The speed of sound in air is 330 m/s.

How long after clapping does the student hear an echo?

- A** 0.30 s **B** 0.61 s **C** 1.7 s **D** 3.3 s

26 Which statement about magnetism is correct?

- A** Aluminium is a ferrous metal.
B A steel magnet can be demagnetised by heating it.
C The core of an electromagnet is usually made of steel.
D The magnetic field lines around a bar magnet are evenly spaced.

27 Two soft-iron rods are placed end to end inside a coil which is connected to a battery.

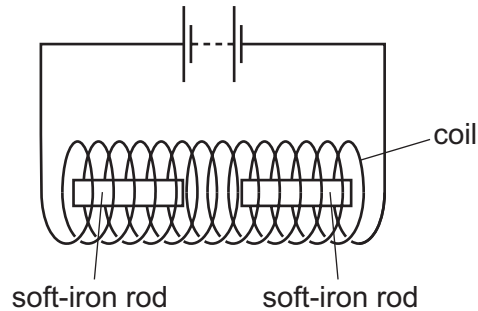

The connections from the battery to the coil are now reversed.

What happens to the soft-iron rods in each case?

	battery connections as shown	battery connections reversed
A	rods attract	rods attract
B	rods attract	rods repel
C	rods repel	rods attract
D	rods repel	rods repel

28 Three charged balls, P, Q and R are suspended by insulating threads. Ball P is positively charged.

Ball Q is brought close to ball P.

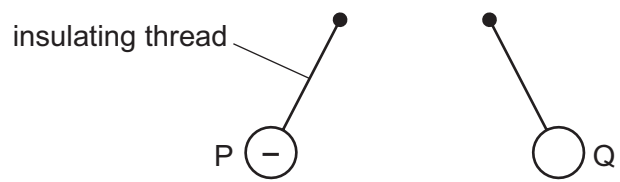

Ball Q is now brought close to ball R.

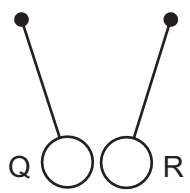

What are the charges on ball Q and on ball R?

	ball Q	ball R
A	positive	positive
B	positive	negative
C	negative	positive
D	negative	negative

29 Which circuit could be used to determine the resistance of the resistor R?

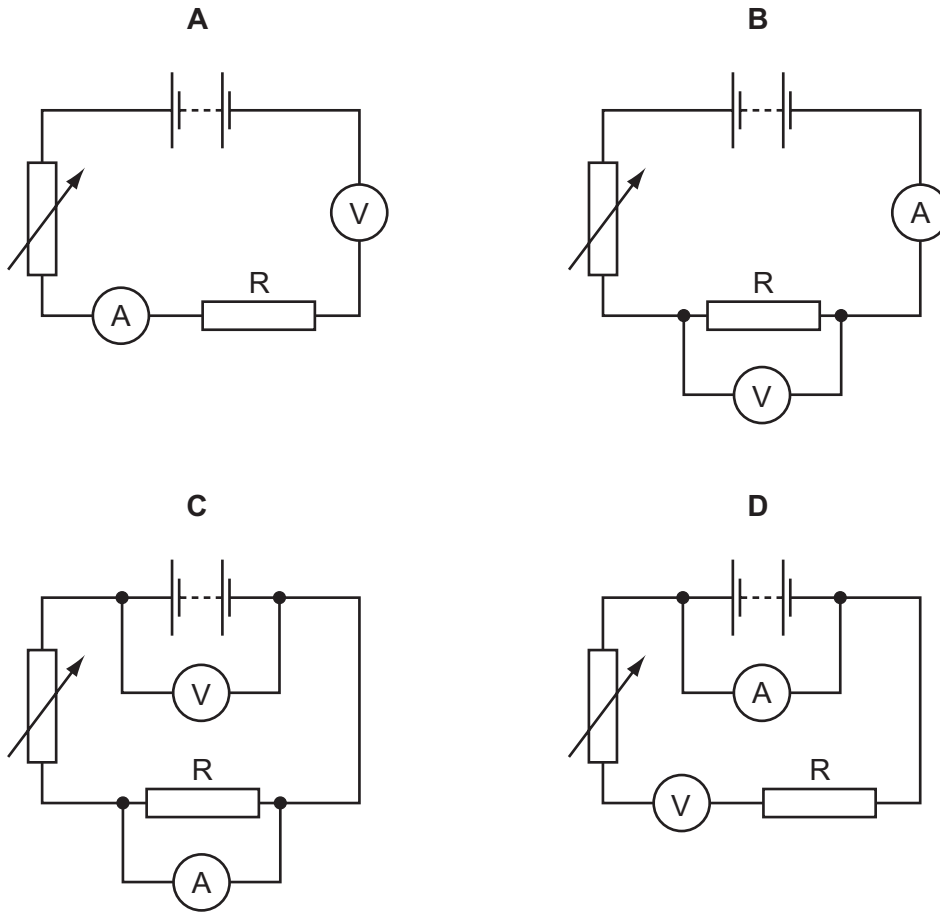

30 Which copper wire would have the smallest resistance?

- A a long, thick wire
- B a long, thin wire
- C a short, thick wire
- D a short, thin wire

31 The diagram shows an electrical circuit.

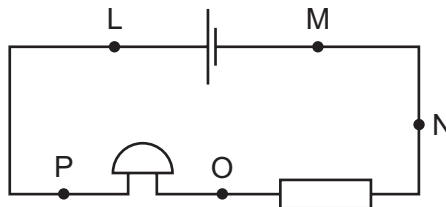

Between which two points must a voltmeter be connected to find the potential difference across the bell?

- A L and M
- B M and N
- C N and O
- D O and P

32 The reading on the ammeter in the circuit is 1.0 A.

A second ammeter is connected in the circuit. It also reads 1.0 A.

At which labelled point is it connected?

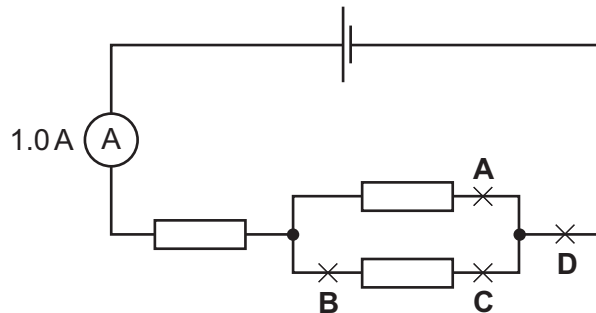

33 The circuit shows a battery and four lamps. All the lamps are lit.

One lamp fails and all the lamps go out.

Which lamp failed?

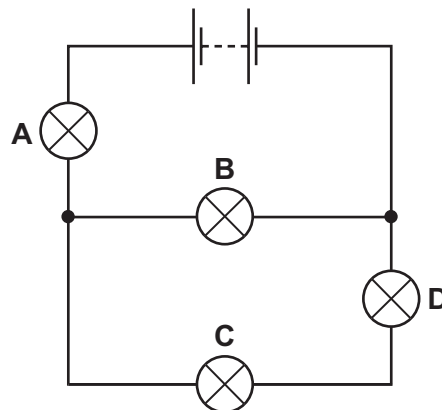

34 A desk lamp should have a 3 A fuse fitted, but a 13 A fuse has been fitted by mistake.

The lamp is not faulty.

The lamp is switched on. What happens?

- A The fuse blows.
- B The fuse does not blow but the lamp does not light.
- C The lamp draws too much current and the supply cables could melt.
- D The lamp works normally.

35 An electric current can produce a heating effect and a magnetic effect.

Which row shows the effect that a relay uses, together with one application of a relay?

	effect used by a relay	one application of a relay
A	heating effect	allowing a small current to switch on a large current
B	heating effect	changing the voltage of an alternating current
C	magnetic effect	allowing a small current to switch on a large current
D	magnetic effect	changing the voltage of an alternating current

36 The diagram shows a mains transformer that has an output voltage of 12 V.

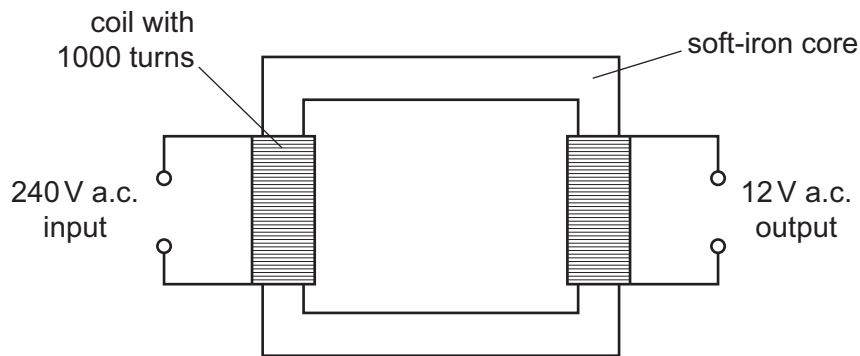

How many turns of wire are in the secondary coil?

- A** 12 **B** 20 **C** 50 **D** 20 000

37 The diagram shows an experiment to demonstrate electromagnetic induction.

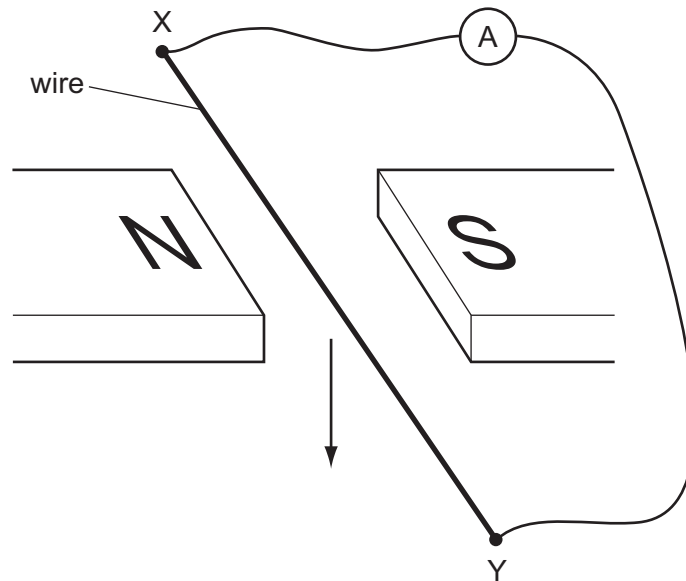

X and Y are joined, in turn, by four wires, each made of a different material.

Each wire is then moved quickly downwards between the magnets.

Which material will **not** give rise to an induced current in the wire?

- A aluminium
- B copper
- C iron
- D nylon

38 In a cathode-ray tube, particles are fired at a screen.

What are these particles?

- A α -particles
- B electrons
- C neutrons
- D protons

39 The graph shows how the count rate on a detector due to a radioactive source changes

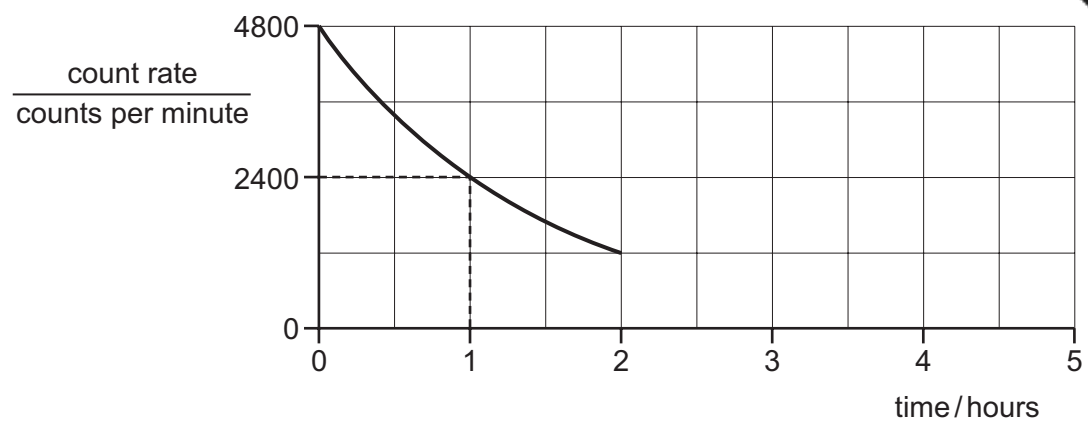

What is the count rate at 5.0 hours?

- A 960 counts per minute
- B 600 counts per minute
- C 150 counts per minute
- D 0 counts per minute

40 The diagram represents a carbon atom.

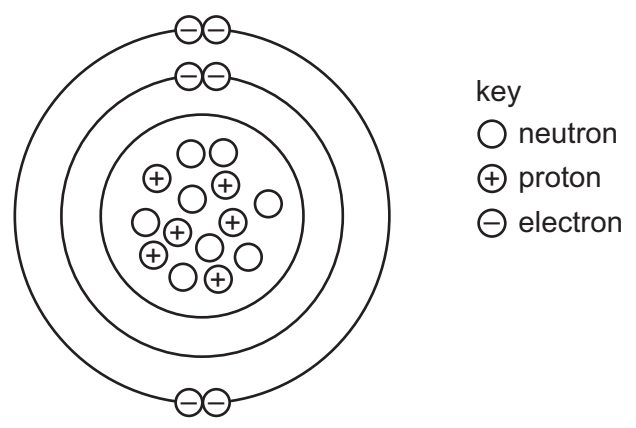

What is the nucleon number (mass number) for this atom?

- A 6
- B 8
- C 14
- D 20

Permission to reproduce items where third-party owned material protected by copyright is included has been sought and cleared where possible. Every reasonable effort has been made by the publisher (UCLES) to trace copyright holders, but if any items requiring clearance have unwittingly been included, the publisher will be pleased to make amends at the earliest possible opportunity.

University of Cambridge International Examinations is part of the Cambridge Assessment Group. Cambridge Assessment is the brand name of University of Cambridge Local Examinations Syndicate (UCLES), which is itself a department of the University of Cambridge.