



Cambridge International Examinations
Cambridge International General Certificate of Secondary Education

PHYSICS**0625/12**

Paper 1 Multiple Choice (Core)

February/March 2018**45 minutes**

Additional Materials: Multiple Choice Answer Sheet
Soft clean eraser
Soft pencil (type B or HB recommended)

* 8 2 0 8 2 2 2 0 4 7 *

**READ THESE INSTRUCTIONS FIRST**

Write in soft pencil.

Do not use staples, paper clips, glue or correction fluid.

Write your name, Centre number and candidate number on the Answer Sheet in the spaces provided unless this has been done for you.

DO NOT WRITE IN ANY BARCODES.There are **forty** questions on this paper. Answer **all** questions. For each question there are four possible answers **A, B, C** and **D**.Choose the **one** you consider correct and record your choice in **soft pencil** on the separate Answer Sheet.**Read the instructions on the Answer Sheet very carefully.**

Each correct answer will score one mark. A mark will not be deducted for a wrong answer.

Any rough working should be done in this booklet.

Electronic calculators may be used.

Take the weight of 1.0 kg to be 10 N (acceleration of free fall = 10 m/s^2).

The syllabus is approved for use in England, Wales and Northern Ireland as a Cambridge International Level 1/Level 2 Certificate.

This document consists of **18** printed pages and **2** blank pages.

2

- 1 A student is asked to find the volume of a small irregularly-shaped piece of rock.
He has the following apparatus available.

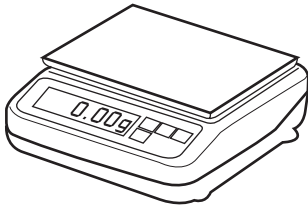

balance

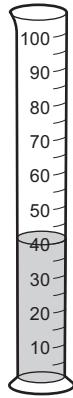
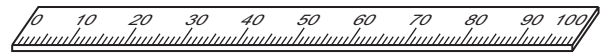
measuring cylinder
containing water

rule

Which apparatus must the student use to find the volume of the small piece of rock?

- A balance and rule
 - B rule only
 - C balance and measuring cylinder
 - D measuring cylinder only
- 2 The speed-time graph represents the motion of a car travelling along a straight level road.

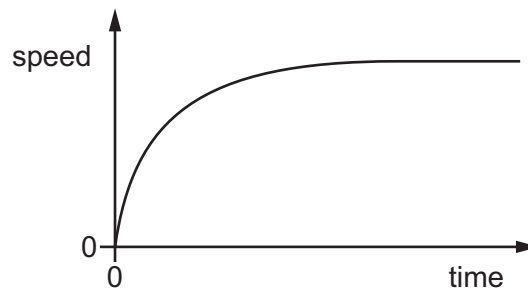

Which statement describes the motion of the car?

- A It accelerates and reaches a constant speed.
- B It accelerates and then stops moving.
- C It decelerates and then reaches a constant speed.
- D It decelerates and then stops moving.

- 3 An athlete runs 300 metres up a hill at a steady speed of 3.0 m/s.
She then immediately runs the same distance down the hill at a steady speed of 6.0 m/s.
What is her average speed for the 600 metre run?
- A 2.0 m/s B 3.0 m/s C 4.0 m/s D 4.5 m/s
- 4 Which statement is correct?
- A Mass is a gravitational force but weight is not a gravitational force.
B Mass is not a gravitational force and weight is not a gravitational force.
C The unit of mass is the kilogram and the unit of weight is the newton.
D The unit of mass is the newton and the unit of weight is the kilogram.
- 5 The diagram shows a bird in flight. The bird is flying in a horizontal direction to the right.
In which direction does air resistance act on the bird?

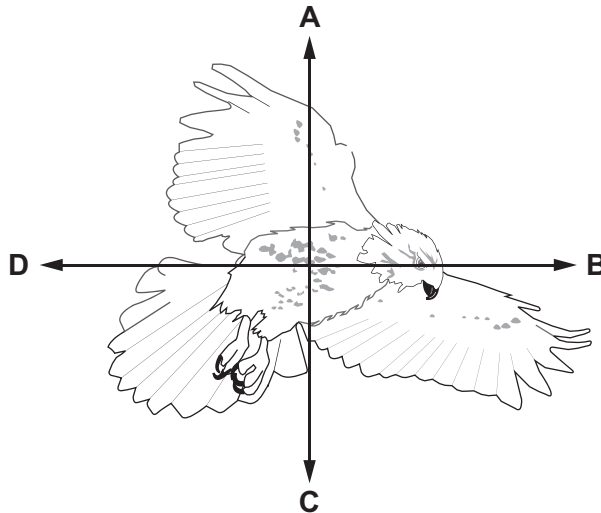

4

- 6 A measuring cylinder contains 30 cm^3 of a liquid.

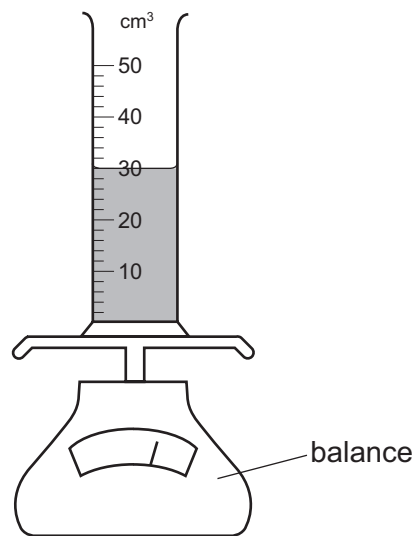

Some more of the liquid is added until the liquid level reaches the 50 cm^3 mark.

The reading on the balance increases by 30 g.

What is the density of the liquid?

- A** 0.60 g/cm^3 **B** 0.67 g/cm^3 **C** 1.5 g/cm^3 **D** 1.7 g/cm^3
- 7 A car is travelling along a straight horizontal road. The speed-time graph is shown.
- In which labelled part of the journey is the resultant force on the car zero?

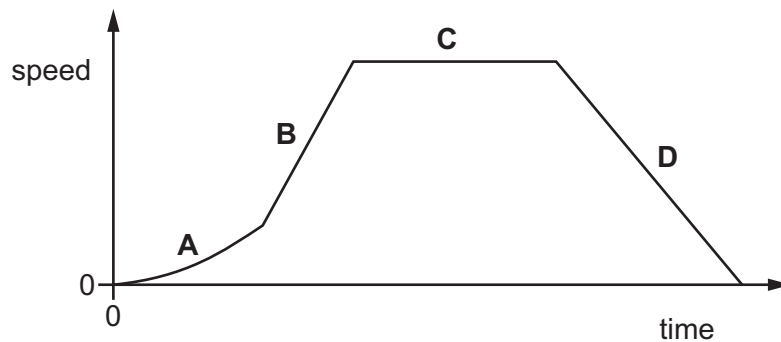

- 8 The diagram shows a uniform metre rule balanced at its mid-point.

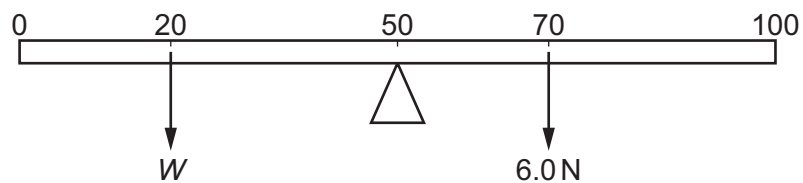

What is the weight W placed at the 20 cm mark?

- A** 0.25 N **B** 4.0 N **C** 9.0 N **D** 21 N

- 9 A wooden plank rests in equilibrium on two rocks on opposite sides of a narrow stream. Three forces P , Q and R act on the plank.

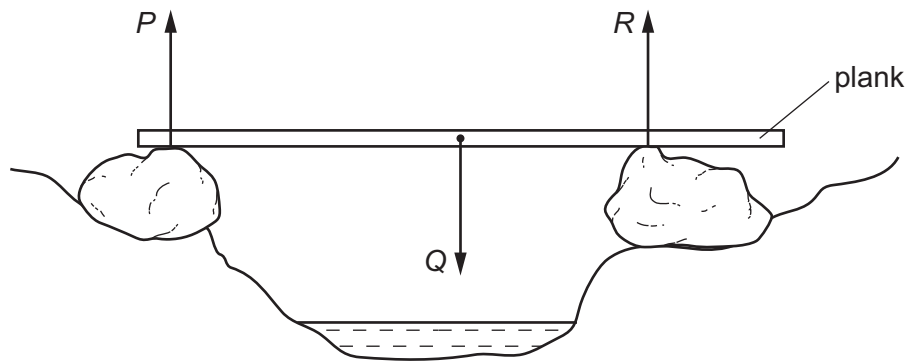

How are the sizes of the forces related?

- A $P + Q = R$
 - B $P + R = Q$
 - C $P = Q = R$
 - D $P = Q + R$
- 10 A ball is at rest at the top of a hill. It rolls down the hill. At the bottom of the hill the ball hits a wall and stops.
- Which energy changes occur?
- A gravitational potential energy \rightarrow internal energy \rightarrow kinetic energy
 - B gravitational potential energy \rightarrow kinetic energy \rightarrow internal energy
 - C kinetic energy \rightarrow gravitational potential energy \rightarrow internal energy
 - D kinetic energy \rightarrow internal energy \rightarrow gravitational potential energy

11 A man pulls a truck a distance of 20 m, as shown in the three diagrams.

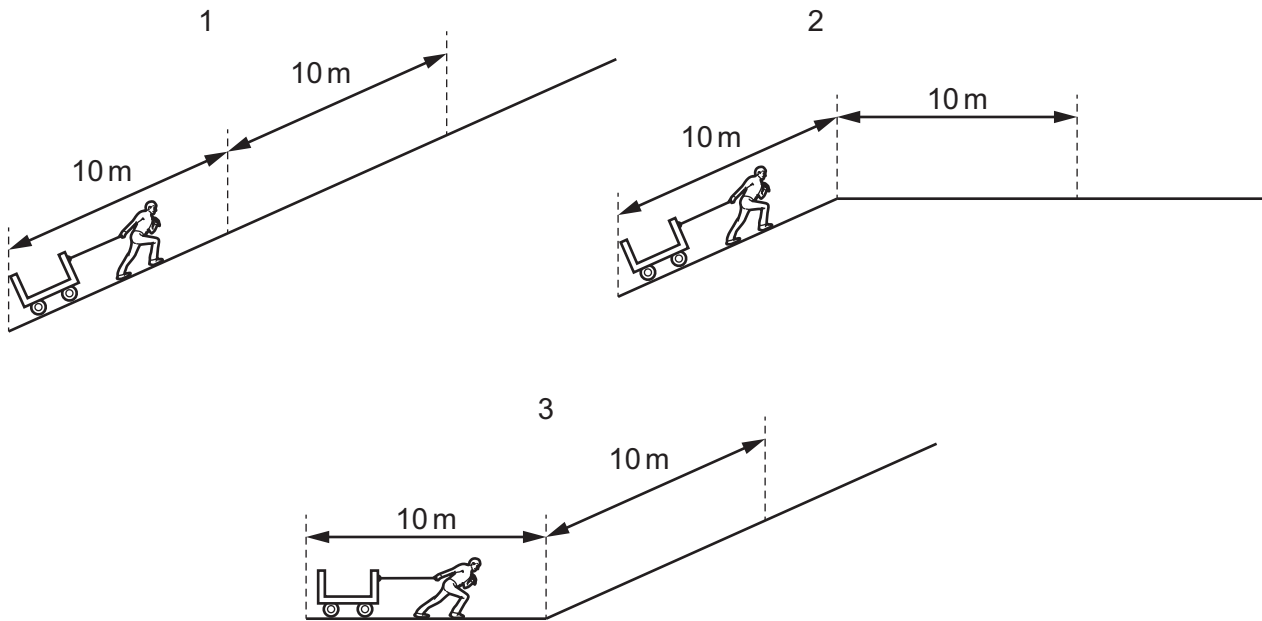

Which statement concerning the work done against gravity is correct?

- A Most work is done in 1.
 - B No work is done in 3.
 - C The work done in all three is equal.
 - D The work done in 1 and 2 is equal.
- 12 Which source of energy is used in a nuclear power station to generate electrical energy?
- A different types of atom regrouping
 - B heavy nuclei splitting
 - C radioactive isotopes decaying
 - D radioactive atoms emitting β -particles
- 13 Two beakers are filled to the same depth, one with water and one with oil.

The density of water is 1000 kg/m^3 and the density of oil is 920 kg/m^3 .

In which position is the pressure the greatest?

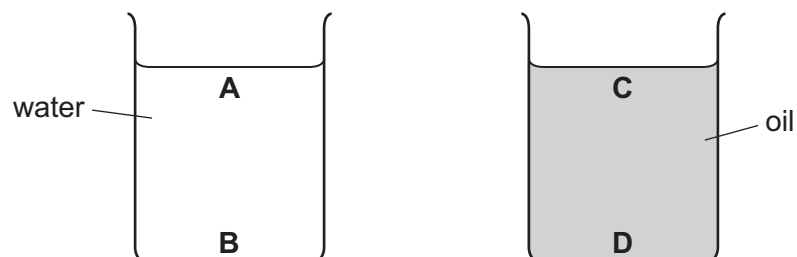

14 A water manometer is connected to a gas supply.

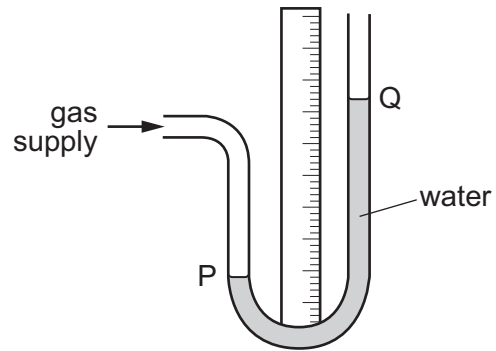

There is a gas leak and the pressure of the gas supply falls.

What happens to the water level at P and what happens to the water level at Q?

	water level at P	water level at Q
A	falls	falls
B	falls	rises
C	rises	falls
D	rises	rises

- 15 A cylinder with a tap contains a fixed mass of gas X. The gas is contained by a piston which can move freely towards or away from the tap.

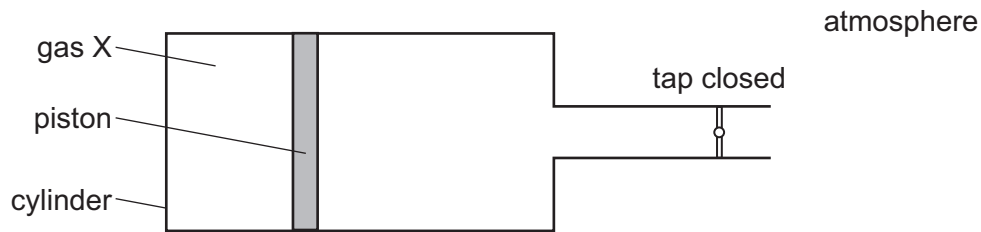

When the tap is opened, the piston moves slightly to the right, towards the tap.

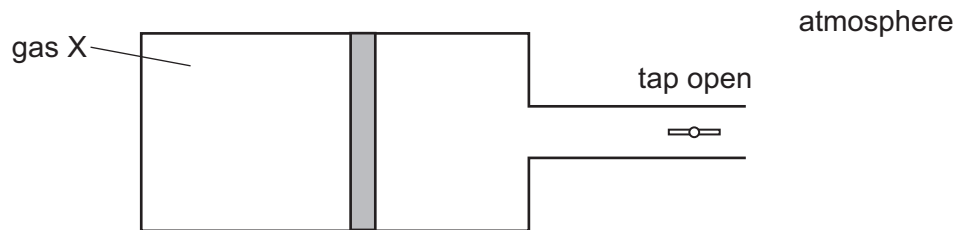

What can be deduced about the pressure of gas X?

	before opening tap	after opening tap
A	less than atmospheric pressure	more than atmospheric pressure
B	same as atmospheric pressure	more than atmospheric pressure
C	more than atmospheric pressure	less than atmospheric pressure
D	more than atmospheric pressure	same as atmospheric pressure

- 16 Which quantity does **not** change when there is an increase in temperature?

- A** the density of a steel block
- B** the diameter of the hole in a metal nut
- C** the length of an iron rod
- D** the mass of a metal coin

- 17 A thermometer has a low thermal capacity.

Why is this an advantage?

- A** The thermometer does not absorb much thermal energy to raise its own temperature.
- B** The thermometer does not conduct much thermal energy to the surroundings.
- C** The thermometer does not melt when it gets hot.
- D** The thermometer does not radiate much thermal energy to the surroundings.

- 18 In an experiment, a thermometer is placed in a test-tube of hot liquid. The temperature reading of the liquid is recorded every half minute. The table shows the results.

time / minutes	0.0	0.5	1.0	1.5	2.0	2.5	3.0	3.5	4.0	4.5	5.0	5.5	6.0	6.5	7.0	7.5
temperature / °C	73	65	59	55	55	55	51	48	45	42	40	38	36	35	34	33

What is the melting point of the substance?

- A 0°C B 33°C C 55°C D 73°C
- 19 A teacher demonstrates an experiment to a class. A boiling tube is filled with water and some ice cubes are trapped at the bottom of the tube. The teacher then heats the boiling tube in the position shown until the water at the top boils.

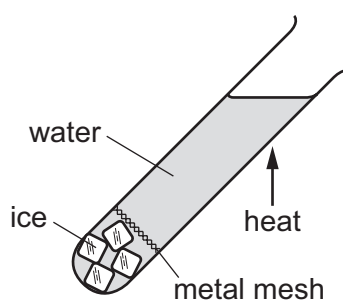

The ice does not melt.

What does this demonstrate?

- A Water is a good conductor of thermal energy.
 B Water is a good convector of thermal energy.
 C Water is a poor conductor of thermal energy.
 D Water is a poor convector of thermal energy.

- 20 A hot metal plate is placed near to a cold metal plate. Infra-red radiation transfers thermal energy between the two plates.

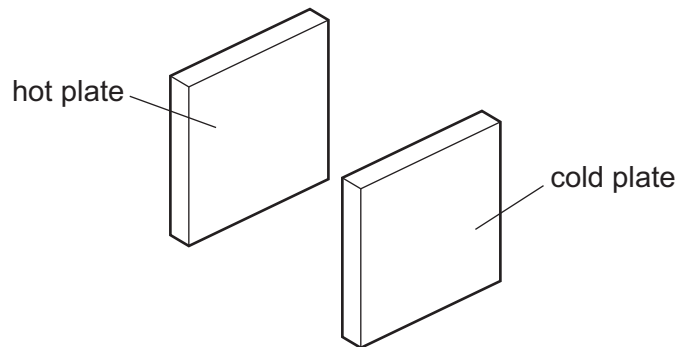

Which choice of colour causes the temperature of the cold plate to increase most slowly?

	hot plate	cold plate
A	matt black	matt black
B	matt black	shiny white
C	shiny white	matt black
D	shiny white	shiny white

- 21 Which row shows an example of a transverse wave and an example of a longitudinal wave?

	transverse	longitudinal
A	light	radio
B	radio	sound
C	sound	water
D	water	light

- 22 An object is placed before a plane mirror as shown.

A student views the image of the object in the mirror from point P.

Where does she see the image?

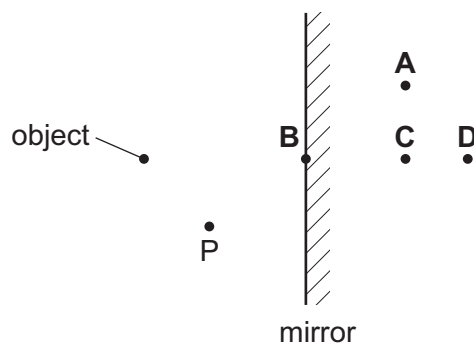

- 23 Light passes through a prism as shown. The light changes direction and produces a spectrum of colours.

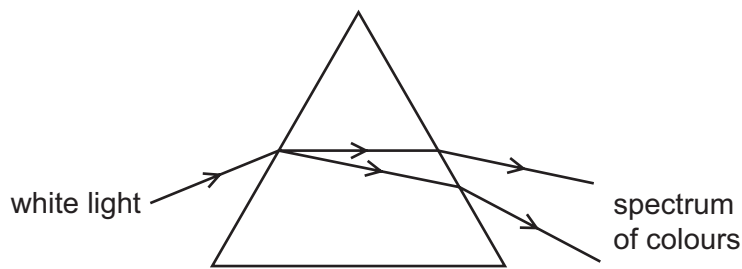

Which term is used to describe the production of the spectrum of colours?

- A diffraction
 - B dispersion
 - C refraction
 - D total internal reflection
- 24 Which type of waves are produced by a television remote controller?
- A infra-red waves
 - B radio waves
 - C ultraviolet waves
 - D visible light
- 25 Both the amplitude and the frequency of a sound wave decrease.
- What happens to the sound heard?
- A The sound is louder and has a higher pitch.
 - B The sound is louder and has a lower pitch.
 - C The sound is quieter and has a higher pitch.
 - D The sound is quieter and has a lower pitch.
- 26 An electromagnet is used to remove a splinter from an eye.
- What material is the splinter made from?
- A aluminium
 - B glass
 - C iron
 - D wood

27 Which diagram shows the magnetic field around a bar magnet?

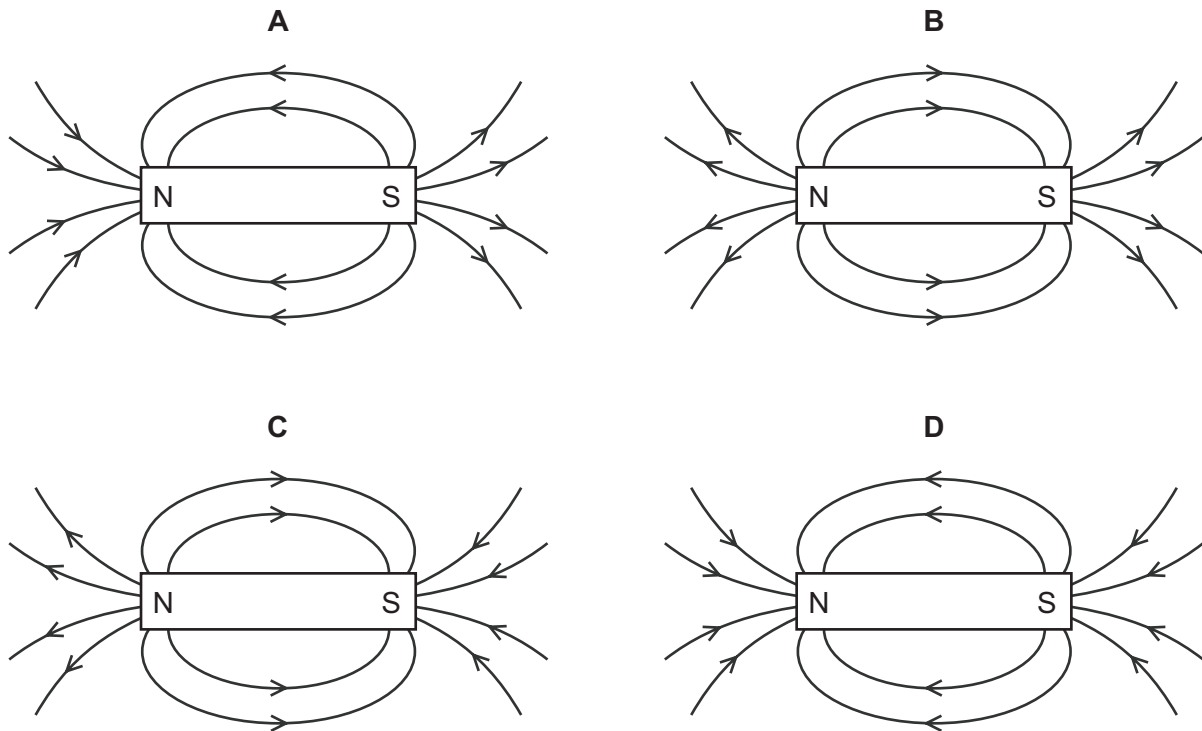

28 A metal conductor is connected to a battery.

Which statement describes the current in the metal conductor?

- A** It is a flow of electrons from the negative to the positive terminal.
- B** It is a flow of electrons from the positive to the negative terminal.
- C** It is a flow of protons from the negative to the positive terminal.
- D** It is a flow of protons from the positive to the negative terminal.

29 A student sets up the circuit shown to measure three quantities.

- 1 the current in the circuit
- 2 the electromotive force (e.m.f.) of the cell
- 3 the potential difference across the lamp

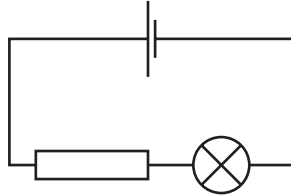

How many ammeters and how many voltmeters are needed?

	ammeters	voltmeters
A	0	3
B	1	2
C	2	1
D	3	0

30 The current in a car headlamp is 3.0 A when connected to a 12 V battery.

What is the resistance of the lamp when it is lit?

- A** 0.25 Ω **B** 4.0 Ω **C** 15 Ω **D** 36 Ω

- 31 The diagram shows a circuit containing a cell, an ammeter, a lamp and a variable resistor.

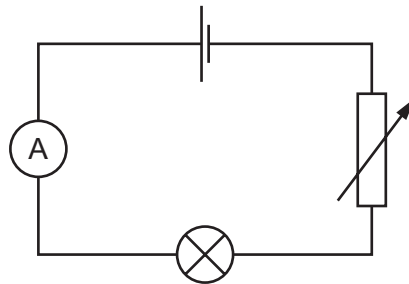

The resistance of the variable resistor is increased.

What happens to the ammeter reading and what happens to the brightness of the lamp?

	ammeter reading	lamp brightness
A	decreases	decreases
B	decreases	increases
C	increases	decreases
D	increases	increases

- 32 Diagram 1 shows two identical lamps connected in series with a cell. Diagram 2 shows the same two lamps connected in parallel with an identical cell.

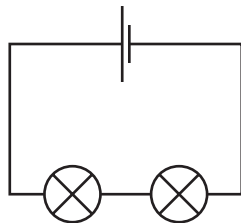

diagram 1

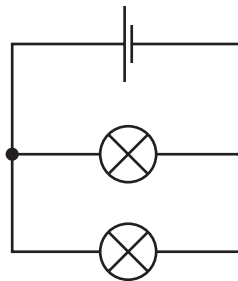

diagram 2

Which statement is correct?

- A** The cell in diagram 1 can supply current to the lamps for longer than the cell in diagram 2.
- B** The current in the cell in diagram 1 is greater than the current in the cell in diagram 2.
- C** The lamps in diagram 1 are brighter than the lamps in diagram 2.
- D** The voltage across each lamp in diagram 1 is greater than the voltage in diagram 2.

33 A circuit contains four ammeters and three resistors with different values.

Which ammeter shows the largest reading?

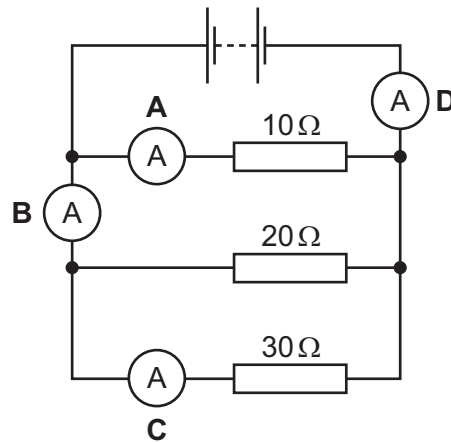

34 The diagram shows the arrangement of the coil, armature and contacts of a relay.

Which diagram shows this arrangement when there is no current in the coil?

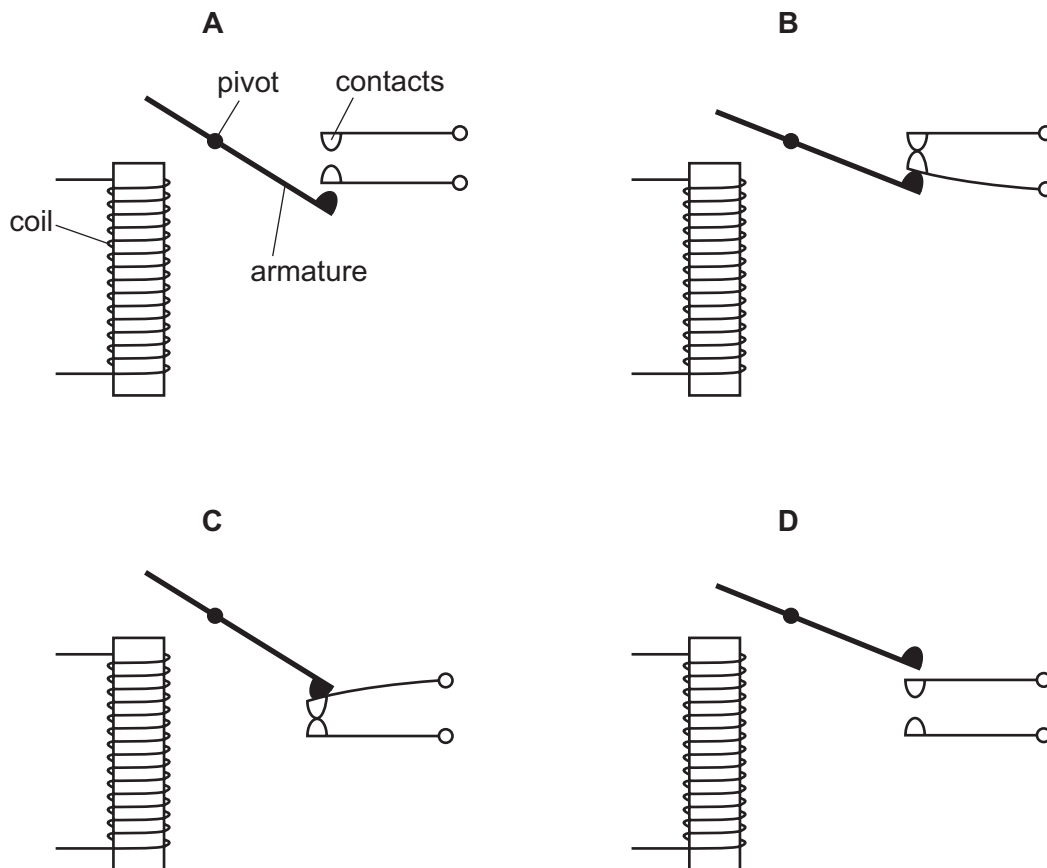

35 The diagram represents a magnetic field.

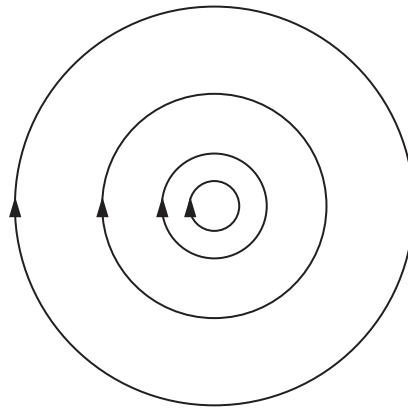

What causes this field?

- A a bar magnet
- B a solenoid carrying a current
- C a straight wire carrying a current
- D two north poles close together

36 The diagram shows a simple d.c. electric motor which is rotating.

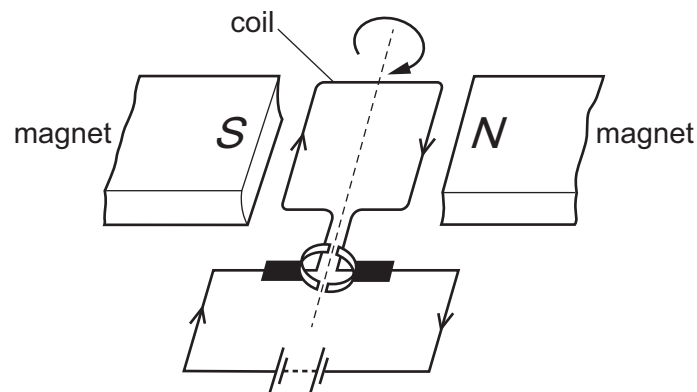

Which change makes the motor rotate more quickly?



- A increasing the number of turns on the coil
- B removing the magnets
- C reversing the battery
- D reversing the polarity of the magnets



37 The notation for an isotope of sodium is ${}_{11}^{23}\text{Na}$.

Which row gives the composition of a neutral atom of this isotope of sodium?

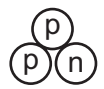
	number of protons	number of neutrons	number of electrons
A	11	12	11
B	11	12	12
C	11	23	11
D	12	11	12

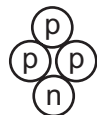
38 Which diagram represents a nucleus of ${}^3_1\text{H}$?

A  **B**  **C**  **D** 

key
 = a neutron
 = a proton

39 When measuring the emissions from a radioactive rock brought into the laboratory, a teacher mentions that background radiation must be taken into account.

What is this background radiation?

- A** infra-red radiation from warm objects in the laboratory
- B** infra-red radiation from the Sun
- C** ionising radiation from the radioactive rock brought into the laboratory
- D** ionising radiation in the laboratory when the radioactive rock is not present

40 The graph shows the percentage of a radioactive isotope that remains as time passes.

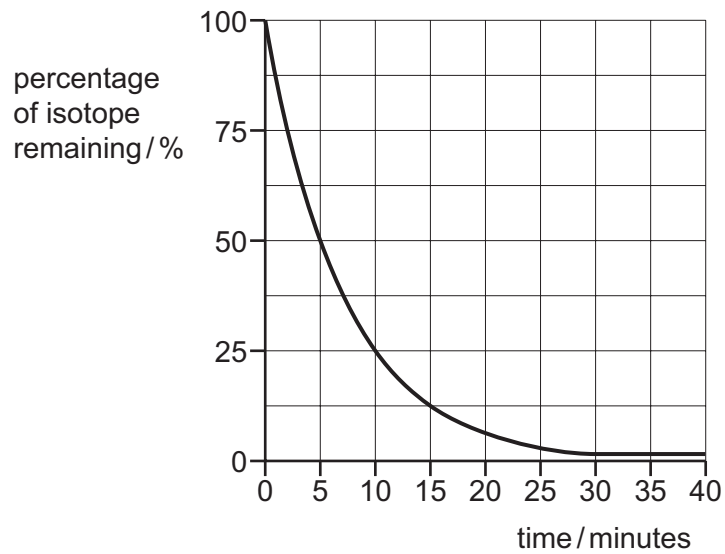

A student measures the initial rate of emission of this isotope as 40 000 emissions per second.

How long does it take for the rate of emission to fall to 5000 emissions per second?

- A** 5 minutes **B** 15 minutes **C** 20 minutes **D** 40 minutes

BLANK PAGE

BLANK PAGE

Permission to reproduce items where third-party owned material protected by copyright is included has been sought and cleared where possible. Every reasonable effort has been made by the publisher (UCLES) to trace copyright holders, but if any items requiring clearance have unwittingly been included, the publisher will be pleased to make amends at the earliest possible opportunity.

To avoid the issue of disclosure of answer-related information to candidates, all copyright acknowledgements are reproduced online in the Cambridge International Examinations Copyright Acknowledgements Booklet. This is produced for each series of examinations and is freely available to download at www.cie.org.uk after the live examination series.

Cambridge International Examinations is part of the Cambridge Assessment Group. Cambridge Assessment is the brand name of University of Cambridge Local Examinations Syndicate (UCLES), which is itself a department of the University of Cambridge.