



Cambridge International Examinations
Cambridge International General Certificate of Secondary Education

COMBINED SCIENCE

0653/51

Paper 5 Practical Test

May/June 2015

CONFIDENTIAL INSTRUCTIONS

Great care should be taken to ensure that any confidential information given does not reach the candidates either directly or indirectly.

The Supervisor's attention is drawn to the form on page 8 which must be completed and returned with the scripts.

If you have any queries regarding these instructions, please contact CIE

by e-mail: info@cie.org.uk

by phone: +44 1223 553554

by fax: +44 1223 553558

stating the nature of the query and the syllabus number quoted above.

This document consists of **6** printed pages and **2** blank pages.

Instructions for preparing apparatus

These instructions detail the apparatus, reagents and specimens required by each candidate for each experiment in this paper. A summary of the questions that will be presented to the candidates is included, where appropriate, to allow the teacher to test the apparatus appropriately. **No access is permitted to the question paper in advance of the examination session.**

It is assumed that the ordinary apparatus of a science laboratory will be available, including a supply of purified water (distilled or deionised).

If arrangements are made for different sessions for different groups of candidates, care must be taken to ensure that the different groups of candidates are effectively isolated so that **no information passes between them.**

All specimens should carry only the code letters and numbers as indicated and their identity should not be revealed to the candidates.

Supervisors should ensure that all specimens have the correct identity attached to the specimen and that these are **not** removed during the examination.

If a candidate breaks any of the apparatus, or loses any of the material supplied, the matter should be rectified and a note made in the Supervisor's Report.

Supervisors are advised to remind candidates that **all** substances in the examination should be treated with caution. Only those tests described in the Question Paper should be attempted. Pipette fillers and safety goggles should be used where necessary.

In accordance with COSHH (Control of Substances Hazardous to Health) Regulations, operative in the UK, a hazard appraisal of the examination has been carried out.

The following codes are used where relevant.

C = corrosive substance

F = highly flammable substance

H = harmful or irritating substance

O = oxidising substance

T = toxic substance

N = harmful to the environment

The attention of Centres is drawn to any local regulations relating to safety, first-aid and disposal of chemicals.

'Hazard Data Sheets', relating to materials used in this examination, should be available from your chemical supplier.

The Supervisor should make sure the Supervisor's Report is fully completed and a copy is enclosed with each packet of scripts.

Centres are reminded that they are **not** permitted to open the question paper envelopes before the examination. Centres are also referred to the Handbook for Centres, the Security of Question Papers and Examination Materials section and the Practical Examinations in Science Subjects section.

If there are difficulties with any aspect of setting up this practical examination that the Centre is not able to resolve, it is essential, for Centres to contact the Product Manager as soon as possible by e-mail to info@cie.org.uk, by phone to +44 1223 553554 or by fax to +44 1223 553558.

Question 1

Each candidate will require

- (i) a fresh celery stalk of 5 - 6 cm length without leaves
- (ii) hand lens
- (iii) white tile
- (iv) knife or cutting blade
- (v) access to Benedict's solution in a dropping bottle, labelled **Benedict's solution**
- (vi) access to biuret solution in a dropping bottle, labelled **biuret solution**
- (vii) access to iodine solution in a dropping bottle, labelled **iodine solution**
- (viii) 3 test-tubes (approx. 125 x15 mm)
- (ix) test-tube rack
- (x) large beaker
- (xi) access to water-bath of at least 80 °C
- (xii) pestle and mortar
- (xiii) stopclock or sight of a clock with a seconds hand
- (xiv) small beaker e.g. 100 cm³ or shallow dish, with red coloured water to a depth of about 1 cm
- (xv) access to distilled water, labelled **distilled water**.

Note: coloured water can be made using 1 cm³ of red food colouring in 100 cm³ distilled water.

Question 2

Each candidate will require

- (i) 2 g of a mixture made up of equal masses of copper(II) oxide and calcium oxide labelled **X**
- (ii) approximately 50 cm³ distilled water, labelled **distilled water**
- [C] (iii) approximately 30 cm³ 1.0 mol dm⁻³ nitric acid, labelled **nitric acid**
- [H] (iv) approximately 50 cm³ 2.0 mol dm⁻³ hydrochloric acid, labelled **hydrochloric acid**
- (v) twelve small (2 – 4 mm) marble chips in a test-tube (approx. 125 mm x 15 mm) fitted with a delivery tube
- (vi) approximately 20 cm³ 2.0 mol dm⁻³ ammonia solution, labelled **ammonia**
- [H] (vii) approximately 30 cm³ 0.4 mol dm⁻³ sodium hydroxide labelled, **sodium hydroxide**
- (viii) 2 test-tubes (approx. 125 mm x 15 mm)
- (ix) 2 test-tubes (approx. 150 mm x 25 mm)
- (x) spatula
- (xi) stirring rod
- (xii) 2 filter funnels (if 1 funnel is supplied it may need washing during the examination)
- (xiii) 3 pieces of filter paper
- (xiv) full range Universal Indicator solution, labelled **Universal Indicator** and with a suitable dropping pipette and chart
- (xv) 2 small beakers (100 cm³)
- (xvi) Bunsen burner and the means to light it
- (xvii) tripod and gauze
- (xviii) dropping pipette
- (xix) red litmus paper
- (xx) 25 cm³ measuring cylinder
- (xxi) paper towels.

Question 3

Each candidate will require

- (i) a steel spring. An expendable steel spring is suitable, for example a 55 mm long spring of diameter 15 mm (see www.philipharris.co.uk, catalogue number B8G87194). The spring must be capable of supporting at least 500 g without overstretching
- (ii) a clamp, stand and boss set up as shown in Fig. 3.1
- (iii) masses of 200 g, 300 g, 400 g and 500 g. A 100 g mass hanger with four 100 g slotted masses is ideal. If these are not available, a suitable light hook must be provided so that the masses can be hung from the spring
- (iv) a stopwatch.

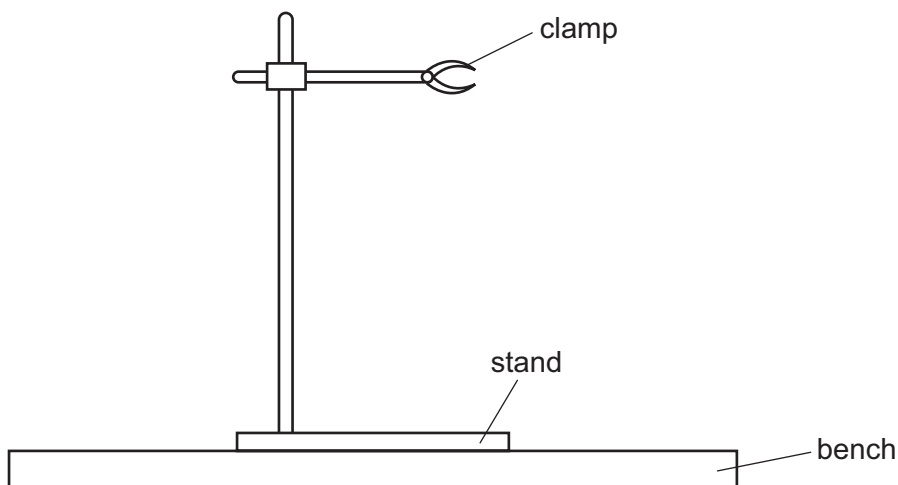

Fig. 3.1

Spare materials and equipment should be available and can be provided without penalty. **Candidates should be made aware of this.**

Information required from the Supervisor:

The Supervisor is asked to carry out the experiments and to enter the results on a spare copy of the examination paper, clearly marked 'Supervisor's Results' and showing the Centre number. This should be done, out of sight of the candidates, using the same solutions, reagents, specimens and apparatus as the candidates.

A copy of the 'Supervisor's Results' should be returned with each packet of scripts. Failure to do so may cause the candidates to be penalised.

BLANK PAGE

BLANK PAGE

This form must be completed and returned in the envelope with the scripts together with the seating plan and the Supervisor's Results as mentioned on page 5.

May/June 2015

General

The Supervisor is invited to give details of any difficulties experienced by particular candidates giving their names and candidate numbers. These should include reference to:

- (a) difficulties due to faulty apparatus;
- (b) accidents to apparatus or materials;
- (c) physical handicaps, e.g. short sight, colour blindness;
- (d) any other information that is likely to assist the Examiner, especially if this cannot be discovered in the scripts;
- (e) any help given to a candidate.

The Supervisor is asked to supply the following information:

Plan of work benches, giving details by candidate numbers of the places occupied by the candidates for each session and a copy of the 'Supervisor's Results'.

NAME OF CENTRE

SIGNED
Supervisor

CENTRE NUMBER

DECLARATION (to be signed by the Principal)

The preparation of this practical examination has been carried out so as to maintain fully the security of the examination.

NAME
(in block capitals)

SIGNED (Principal)



Permission to reproduce items where third-party owned material protected by copyright is included has been sought and cleared where possible. Every reasonable effort has been made by the publisher (UCLES) to trace copyright holders, but if any items requiring clearance have unwittingly been included, the publisher will be pleased to make amends at the earliest possible opportunity.

To avoid the issue of disclosure of answer-related information to candidates, all copyright acknowledgements are reproduced online in the Cambridge International Examinations Copyright Acknowledgements Booklet. This is produced for each series of examinations and is freely available to download at www.cie.org.uk after the live examination series.

Cambridge International Examinations is part of the Cambridge Assessment Group. Cambridge Assessment is the brand name of University of Cambridge Local Examinations Syndicate (UCLES), which is itself a department of the University of Cambridge.