



Cambridge International Examinations
Cambridge International General Certificate of Secondary Education

CANDIDATE
NAME

CENTRE
NUMBER

--	--	--	--	--

CANDIDATE
NUMBER

--	--	--	--

* 4 3 1 2 7 6 5 6 7 4 *



COMBINED SCIENCE

0653/52

Paper 5 Practical Test

May/June 2015

1 hour 30 minutes

Candidates answer on the Question Paper.

Additional Materials: As listed in the Confidential Instructions.

READ THESE INSTRUCTIONS FIRST

Write your Centre number, candidate number and name on all the work you hand in.

Write in dark blue or black pen.

You may use an HB pencil for any diagrams or graphs.

Do not use staples, paper clips, glue or correction fluid.

DO NOT WRITE IN ANY BARCODES.

Answer **all** questions.

Electronic calculators may be used.

You may lose marks if you do not show your working or if you do not use appropriate units.

Notes for Use in Qualitative Analysis for this paper are printed on page 12.

At the end of the examination, fasten all your work securely together.

The number of marks is given in brackets [] at the end of each question or part question.

For Examiner's Use	
1	
2	
3	
Total	

This document consists of **11** printed pages and **1** blank page.

- 1 Catalase is an enzyme found in potato cells. It is involved in the breakdown of hydrogen peroxide into water and oxygen. The oxygen is released as oxygen bubbles.

You are going to investigate how the rate of this reaction is affected by the thickness of potato pieces.

(a) Read through the instructions for the whole of part (a) carefully before starting.

Table 1.1

thickness of potato slice / mm	time taken for potato slice to rise / s		
	experiment 1	experiment 2	average
5			
4			
3			
2			
1			

- (i)
- Take **one** of the potato cylinders and remove any skin by trimming off about 1 cm from the end and discard this piece into the waste container.
 - Using the ruler and knife, cut a 5 mm thick slice from the freshly cut end.
 - Using forceps, pick up this slice and place it at the bottom of the beaker containing hydrogen peroxide. At the same time that the potato enters the hydrogen peroxide, start the stopclock.
 - The slice of potato will begin to rise to the surface as it gets covered with bubbles. **When it reaches the surface, stop the stopclock.**
 - Using forceps, **immediately** remove and discard this potato slice.

Record in Table 1.1 the time it takes, to the nearest second, for the slice to rise to the surface of the hydrogen peroxide (experiment 1).

- Repeat the procedure with potato slices of thicknesses of 4 mm, 3 mm, 2 mm and 1 mm. Record these times in Table 1.1 (experiment 1). [1]
- (ii) Using the same hydrogen peroxide, repeat the procedures in (a)(i), cutting fresh potato slices from the **other** potato cylinder. Record your results in Table 1.1 (experiment 2). [2]

(b) Calculate the average time for each thickness of potato slice and complete Table 1.1. [1]

3

- (c) On the grid provided plot a graph of the average time taken on the vertical axis, against slice thickness on the horizontal axis.

Draw a best fit straight line through the origin.

time taken
for potato
slice to rise / s

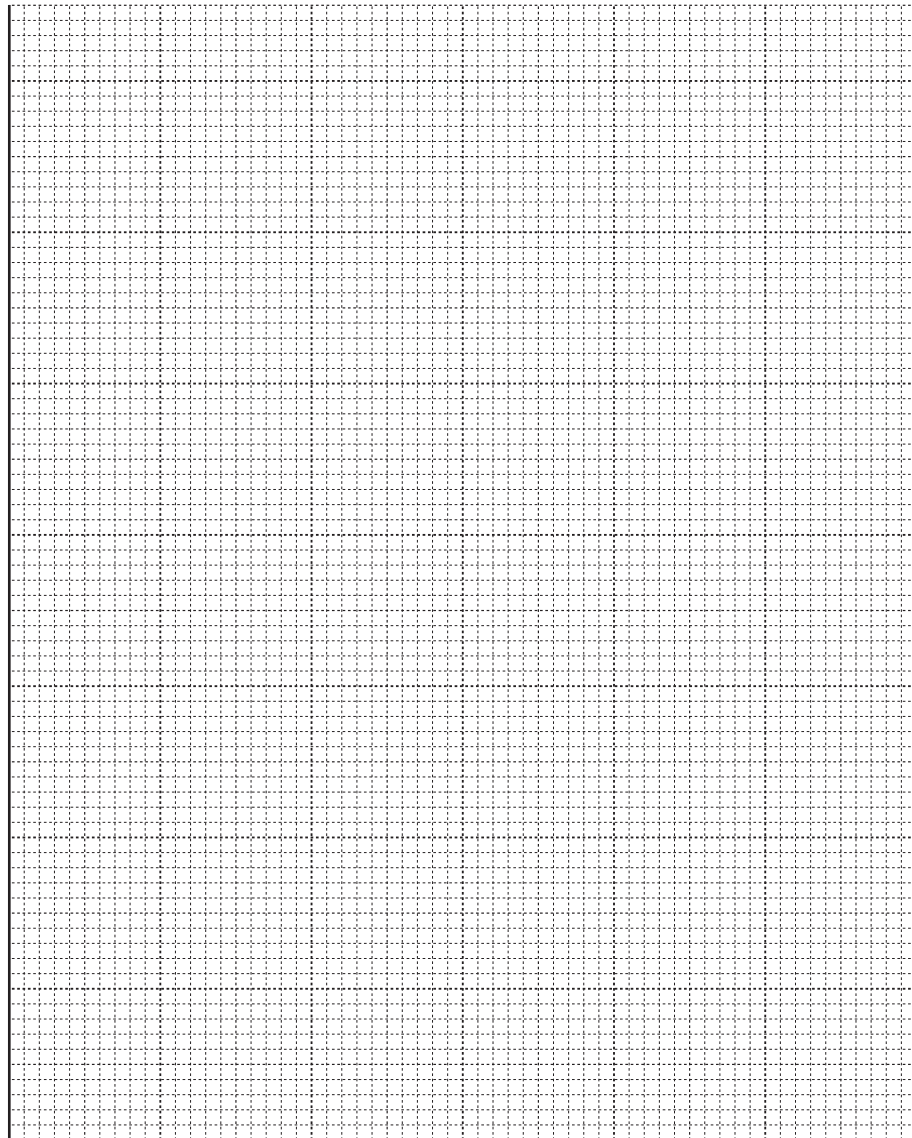

thickness of potato slice / mm

[3]

- (d) Use your graph to estimate the time that a 2.5 mm slice would take to rise to the surface.

Draw lines on your graph to show how you worked this out.

time taken = s [1]

(e) A student suggests that in experiment 2 in part (a) fresh hydrogen peroxide should be used.

(i) Explain why this would make the experiment a fairer test.

.....
..... [1]

(ii) Compare your results in Table 1.1 for experiment 1 and experiment 2 to explain whether using fresh hydrogen peroxide would make a difference.

.....
..... [1]

Please turn over for Question 2.

- 2 You are provided with samples of four compounds as solids **A**, **B**, **C** and **D**. One of the solids is sodium carbonate and the others are copper sulfate, sodium chloride and zinc sulfate.

You will carry out tests to find the identities of **A**, **B**, **C** and **D**. For this purpose you are provided with the following reagents:

- ammonia solution
- barium chloride solution
- dilute hydrochloric acid
- limewater
- silver nitrate solution

- (a) Find out which solid contains carbonate.

Add one third of a test-tube of dilute hydrochloric acid to no more than half of **each** solid in separate test-tubes and bubble any gas produced through limewater.

Record your observations in Table 2.1 and indicate which compound is the carbonate.

Table 2.1

	solid A	solid B	solid C	solid D
observations				
carbonate present? (yes/no)				

[3]

(b) Now put to one side the solid you have identified as a carbonate. You will **not** need this again. You will now test the three remaining samples.

(i) Dissolve one small spatula load of **one** of the remaining solids in a large test-tube containing one third distilled water. You may need to stir the mixture.

Divide this solution equally into three test-tubes. Place the test-tubes into the test-tube rack.

Carry out the following tests:

- Add barium chloride solution to one test-tube.
- Add silver nitrate solution to the second test-tube.
- Add ammonia solution to the third test-tube.

Record your observations in the first empty column of Table 2.2. Complete the 'solid...' heading.

(ii) Repeat **(i)** using the second remaining solid.

(iii) Repeat **(i)** using the third remaining solid.

Table 2.2

test	(b)(i)	(b)(ii)	(b)(iii)
	solid	solid	solid
barium chloride solution			
silver nitrate solution			
ammonia solution			

[5]

(c) (i) State which solid is sodium chloride.

sodium chloride is solid

[1]

(ii) You have now identified sodium carbonate and sodium chloride.

Using your observations in **(b)**, state which solids are copper sulfate and zinc sulfate.

copper sulfate is

zinc sulfate is

[1]

- 3 You are going to measure the focal length of a convex lens.

Set up the apparatus as shown in Fig. 3.1. The distance between the front of the lamp and the illuminated object should be 2 to 3 cm.

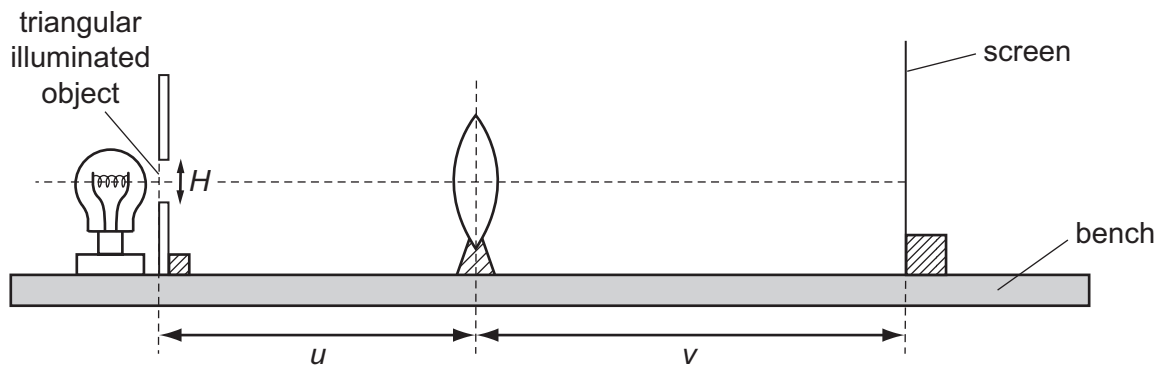

Fig. 3.1

- (a) Measure and record in millimetres to the nearest millimetre, the height H of **your** triangular illuminated object. Fig. 3.2 shows where you should measure H .

$H = \dots\dots\dots$ mm [1]

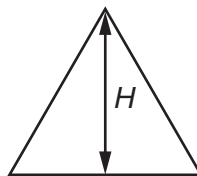

Fig. 3.2

- (b) (i) Switch on the lamp and place the lens at a distance $u = 25.0$ cm from the illuminated object. Adjust the position of the screen by moving it backwards and forwards along the bench until a sharp triangular image of the illuminated object is formed on the screen.

Measure, as accurately as you can, the image distance v from the screen to the lens. Record the distance v in Table 3.1. [1]

- (ii) Measure, and record in millimetres in Table 3.1, the height h of this **image on the screen**. [1]

Table 3.1

u /cm	v /cm	h /mm	$m = \frac{h}{H}$
25.0			
30.0			
35.0			
40.0			
45.0			

(iii) Repeat the procedure described in (b)(i) and (b)(ii) for values of u of 30.0 cm, 35.0 cm, 40.0 cm and 45.0 cm. [2]

(iv) Use your result from (a) and the values of h in the table to complete the final column in Table 3.1 by calculating each ratio $\frac{h}{H}$. This ratio is called the magnification m of the image. [1]

(c) (i) On the grid provided, plot a graph of v against m . Draw the best fit straight line.

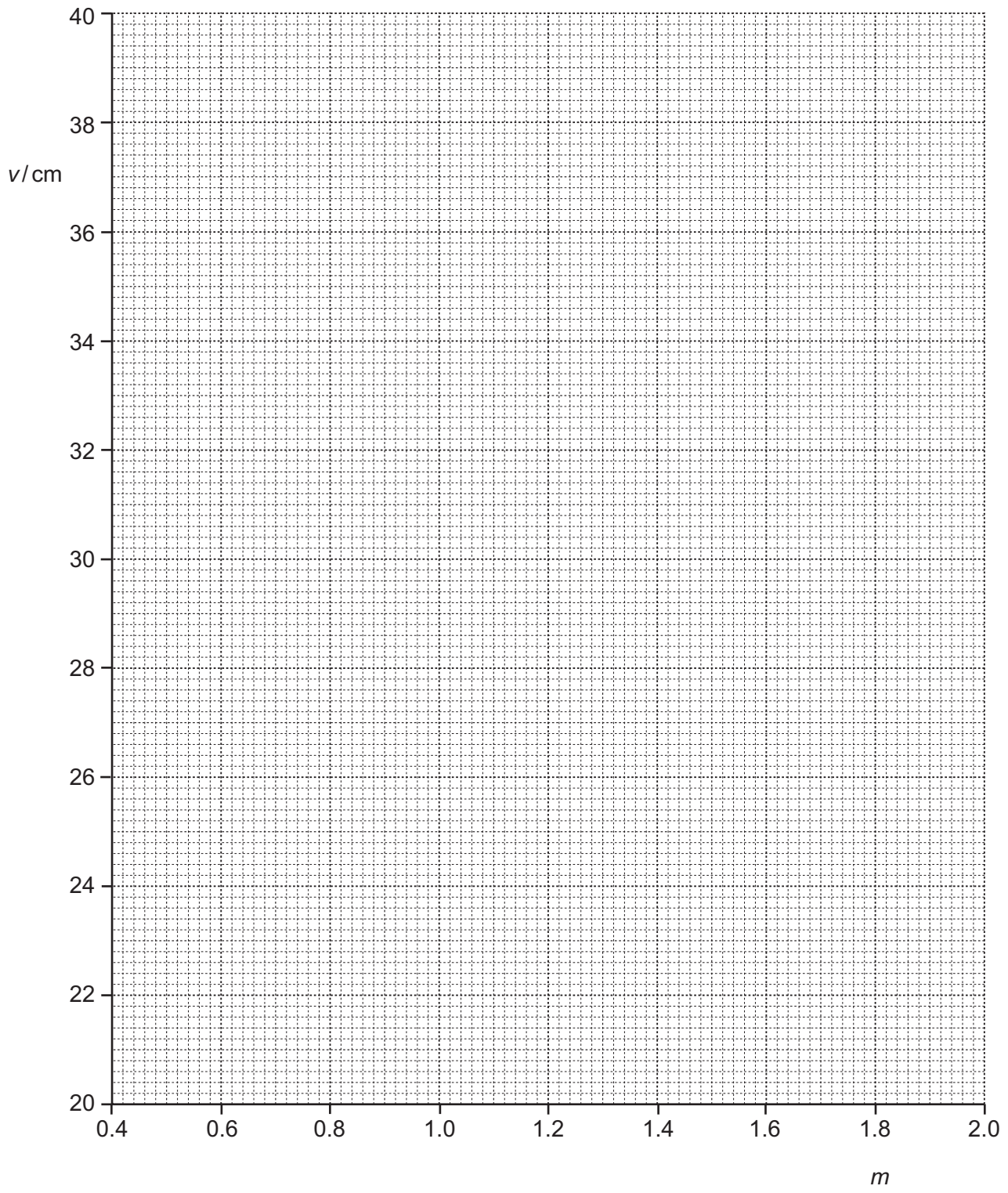

[2]

(ii) The gradient of your graph is equal to the focal length f of the lens.

Calculate the gradient of your line. **Show all working and indicate on your graph** the values you chose to enable an accurate value of the gradient to be calculated.

gradient = f = cm [2]

BLANK PAGE

NOTES FOR USE IN QUALITATIVE ANALYSIS

Test for anions

<i>anion</i>	<i>test</i>	<i>test result</i>
carbonate (CO_3^{2-})	add dilute acid	effervescence, carbon dioxide produced
chloride (Cl^-) [in solution]	acidify with dilute nitric acid, then add aqueous silver nitrate	white ppt.
nitrate (NO_3^-) [in solution]	add aqueous sodium hydroxide then aluminium foil; warm carefully	ammonia produced
sulfate (SO_4^{2-}) [in solution]	acidify then add aqueous barium chloride <i>or</i> aqueous barium nitrate	white ppt.

Test for aqueous cations

<i>cation</i>	<i>effect of aqueous sodium hydroxide</i>	<i>effect of aqueous ammonia</i>
ammonium (NH_4^+)	ammonia produced on warming	-
copper(II) (Cu^{2+})	light blue ppt., insoluble in excess	light blue ppt., soluble in excess giving a dark blue solution
iron(II) (Fe^{2+})	green ppt., insoluble in excess	green ppt., insoluble in excess
iron(III) (Fe^{3+})	red-brown ppt., insoluble in excess	red-brown ppt., insoluble in excess
zinc (Zn^{2+})	white ppt., soluble in excess giving a colourless solution	white ppt., soluble in excess giving a colourless solution

Test for gases

<i>gas</i>	<i>test and test results</i>
ammonia (NH_3)	turns damp red litmus paper blue
carbon dioxide (CO_2)	turns limewater milky
chlorine (Cl_2)	bleaches damp litmus paper
hydrogen (H_2)	"pops" with a lighted splint
oxygen (O_2)	relights a glowing splint

Permission to reproduce items where third-party owned material protected by copyright is included has been sought and cleared where possible. Every reasonable effort has been made by the publisher (UCLES) to trace copyright holders, but if any items requiring clearance have unwittingly been included, the publisher will be pleased to make amends at the earliest possible opportunity.

To avoid the issue of disclosure of answer-related information to candidates, all copyright acknowledgements are reproduced online in the Cambridge International Examinations Copyright Acknowledgements Booklet. This is produced for each series of examinations and is freely available to download at www.cie.org.uk after the live examination series.

Cambridge International Examinations is part of the Cambridge Assessment Group. Cambridge Assessment is the brand name of University of Cambridge Local Examinations Syndicate (UCLES), which is itself a department of the University of Cambridge.