



# Cambridge IGCSE™

CANDIDATE  
NAME

CENTRE  
NUMBER

--	--	--	--	--

CANDIDATE  
NUMBER

--	--	--	--

**COMBINED SCIENCE**

**0653/42**

Paper 4 Theory (Extended)

**February/March 2022**

**1 hour 15 minutes**

You must answer on the question paper.

No additional materials are needed.

## INSTRUCTIONS

- Answer **all** questions.
- Use a black or dark blue pen. You may use an HB pencil for any diagrams or graphs.
- Write your name, centre number and candidate number in the boxes at the top of the page.
- Write your answer to each question in the space provided.
- Do **not** use an erasable pen or correction fluid.
- Do **not** write on any bar codes.
- You may use a calculator.
- You should show all your working and use appropriate units.

## INFORMATION

- The total mark for this paper is 80.
- The number of marks for each question or part question is shown in brackets [ ].
- The Periodic Table is printed in the question paper.

This document has **24** pages. Any blank pages are indicated.

1 (a) Fig. 1.1 shows part of a food web.

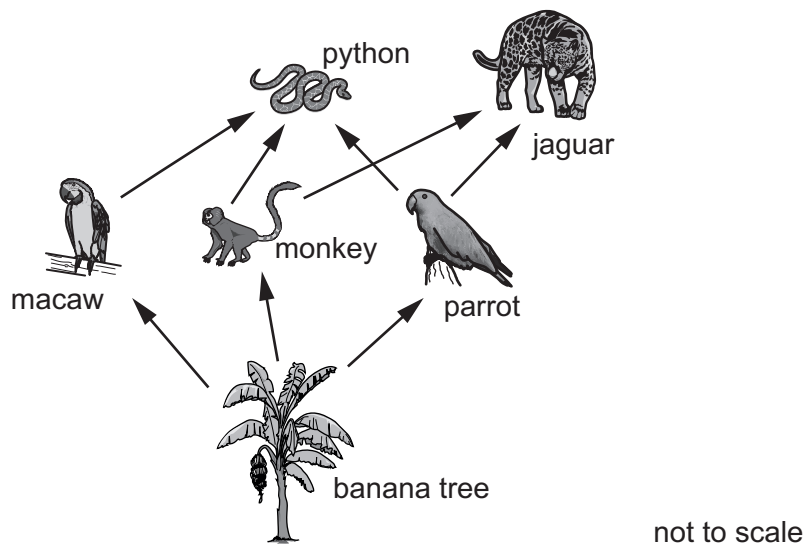

Fig. 1.1

(i) Construct a food chain using Fig. 1.1 that includes the macaw.

..... [2]

(ii) Describe how energy is transferred from the banana tree to the jaguar.

.....  
.....  
..... [2]

- (b) The leaves of a banana tree contain parts with different functions. The different parts have features that help them with their function.

Table 1.1 shows some of the parts of the leaf, their feature and their function.

Complete Table 1.1.

**Table 1.1**

part of leaf	feature	function
palisade mesophyll layer	.....	photosynthesis
spongy mesophyll layer	air spaces	.....
xylem tissue	hollow	.....

[3]

- (c) Fig. 1.2 is a graph showing the effect of light intensity on the rate of photosynthesis.

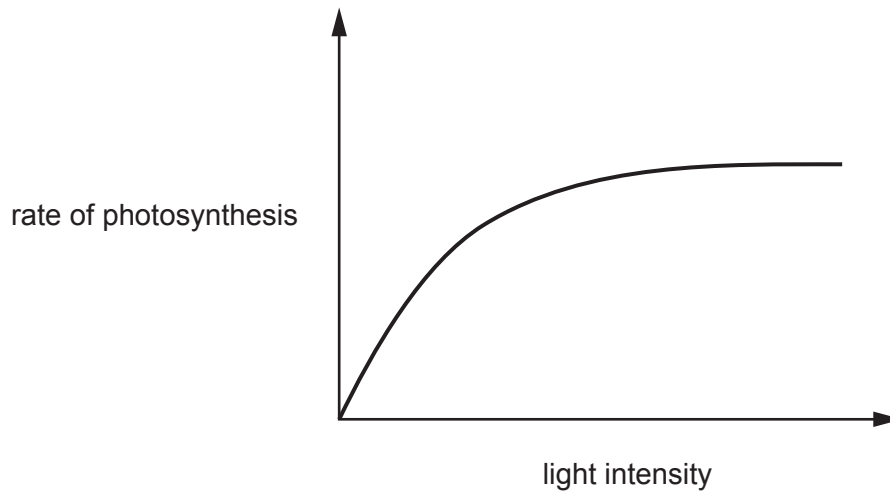

**Fig. 1.2**

Describe the effect of light intensity on the rate of photosynthesis in Fig. 1.2.

.....

.....

..... [2]

[Total: 9]

- 2 Fig. 2.1 shows only the outer shell electrons in atoms of elements **X**, **Y** and **Z**.

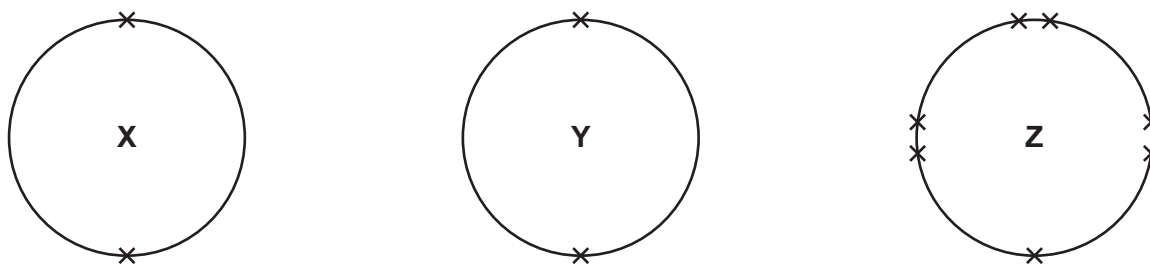

Fig. 2.1

- (a) State which element, **X**, **Y** or **Z**, is a halogen.

Explain your answer.

element .....

explanation .....

.....

[1]

- (b) Table 2.1 shows the formula and some information about substances which contain the elements **X**, **Y** and **Z**.

Table 2.1

formula	state at room temperature	other information
$\text{XZ}_2$	solid	ionic compound
<b>X</b>	solid	metal
<b>Y</b>	gas	exists as single atoms
$\text{Z}_2$	gas	exists as molecules

- (i) Use the information in Fig. 2.1 and Table 2.1 to identify the group of the Periodic Table to which element **X** belongs.

Explain your answer.

group .....

explanation .....

.....

.....

[2]

- (ii) Element **Y** is **not** in the same group of the Periodic Table as element **X**.

Explain how information in Table 2.1 shows that elements **X** and **Y** are in different groups.

.....  
 ..... [1]

- (iii) Identify element **Y**.

..... [1]

- (iv) Put ticks (✓) in the boxes to show which statements about **Z<sub>2</sub>** are true and which are false.

statement	true	false
The bond between two atoms in <b>Z<sub>2</sub></b> is a double bond.		
The bonding in <b>Z<sub>2</sub></b> is covalent.		
<b>Z<sub>2</sub></b> molecules are diatomic.		
<b>Z<sub>2</sub></b> is non-metallic.		

[2]

- (v) The ionic solid **XZ<sub>2</sub>** contains ions of element **X** and ions of element **Z**.  
 State the charge on each of these ions.

Explain your answers.

charge on an ion of element **X** .....

charge on an ion of element **Z** .....

explanation .....

.....

.....

[3]

[Total: 10]

3 A child in a toy car moves forward at a constant speed of  $0.7 \text{ m/s}$ .

The car and child have a total mass of  $20 \text{ kg}$ .

Fig. 3.1 shows the forces acting on the car.

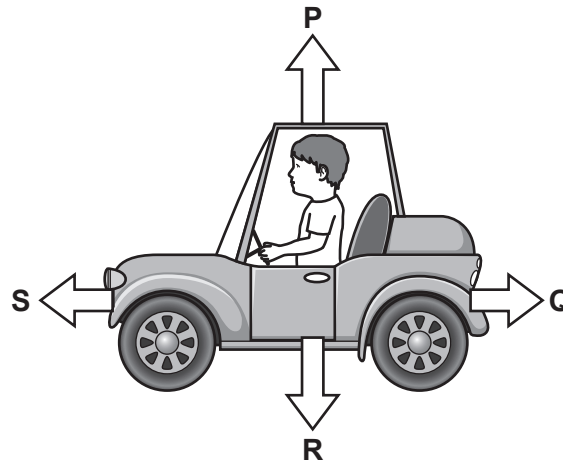

Fig. 3.1

(a) (i) State the name of force **Q**.

.....

[1]

(ii) Force **S** is  $25 \text{ N}$ .

State the magnitude of force **Q**.

force **Q** = ..... N [1]

(b) Calculate the kinetic energy of the car and child.

kinetic energy = ..... J [2]

(c) Fig. 3.2 shows a speed–time graph for the motion of the toy car.

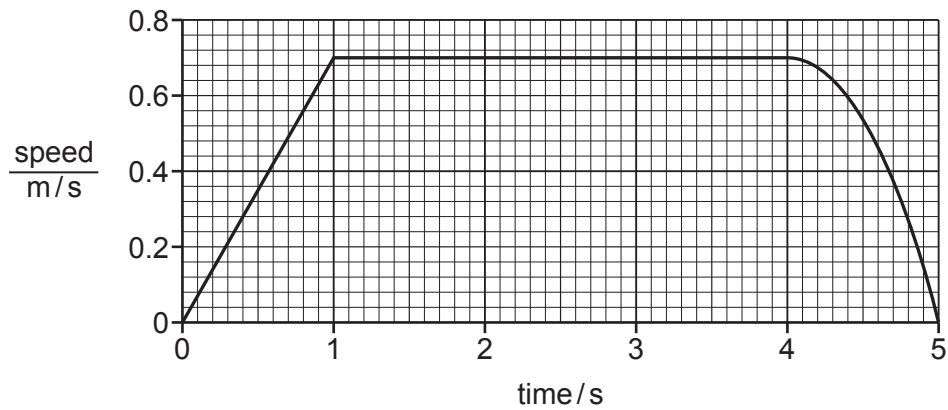

**Fig. 3.2**

(i) Calculate the distance travelled by the car in the first 4 seconds of its motion.

distance = ..... m [3]

(ii) Calculate the acceleration of the car between time = 0 s and time = 1 s.

Give the units of your answer.

acceleration = ..... units ..... [3]

[Total: 10]

4 (a) Fig. 4.1 shows the first part of the alimentary canal and associated organs.

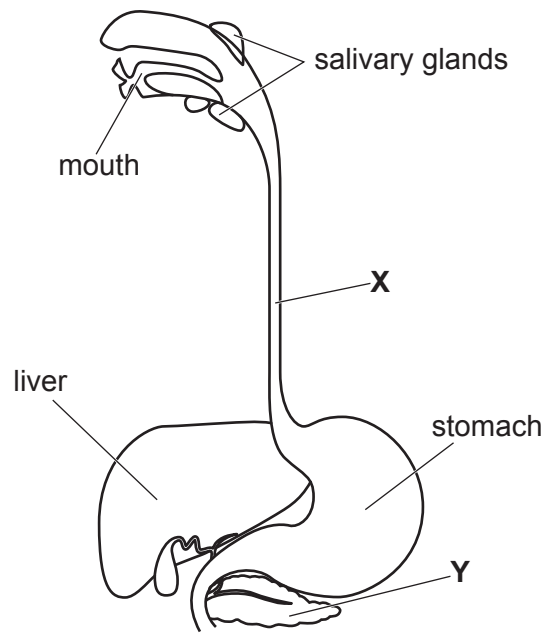

Fig. 4.1

(i) Identify structures X and Y in Fig. 4.1.

X .....

Y ..... [2]

(ii) Explain the importance of salivary glands to chemical digestion in the mouth.

.....

.....

.....

..... [3]

(b) Describe the dietary importance of fibre (roughage).

.....

..... [1]



(c) Water moves in and out of cells in the body.

Fig. 4.2 shows a red blood cell in a beaker of concentrated sugar solution.

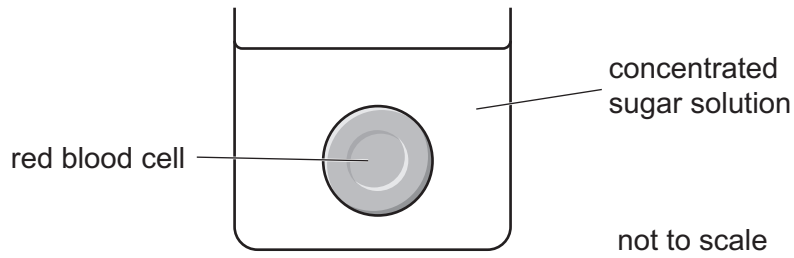

Fig. 4.2

The cell in Fig. 4.2 loses water and shrinks.

Explain why.

Use ideas about water potential in your answer.

.....  
.....  
.....  
.....  
..... [3]

(d) Red blood cells are found inside capillaries.

Explain how the structure of capillaries is adapted to their function.

.....  
.....  
..... [2]

[Total: 11]

- 5 Hydrogen and oxygen are made when dilute sulfuric acid is electrolysed using inert electrodes, as shown in Fig. 5.1.

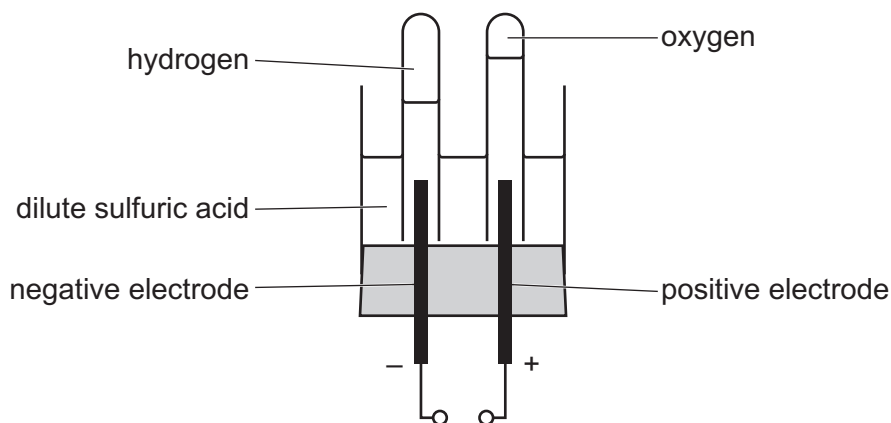

Fig. 5.1

- (a) Describe the tests and positive results for hydrogen and for oxygen.

test for hydrogen .....

result .....

test for oxygen .....

result .....

[2]

- (b) The ionic equations for the reaction at each electrode are shown.

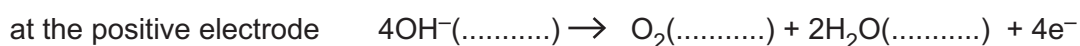
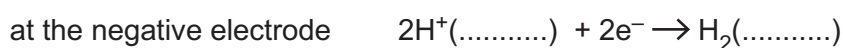

- (i) Complete the ionic equations by adding in the missing state symbols. [2]

- (ii) Explain the changes that happen at each electrode.

Use ideas about electrons in your answer.

.....  
 .....  
 .....  
 .....

[2]

(c) The sulfuric acid is **not** all used up during the electrolysis.

State a test and its result to show that the solution is acidic at the end of the electrolysis.

test .....

result .....

[1]

[Total: 7]

- 6 (a) Fig. 6.1 shows a thin converging lens.

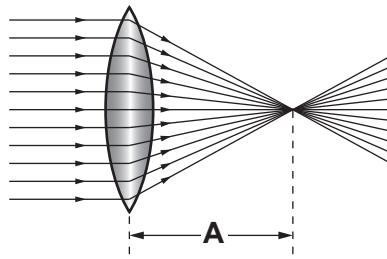

Fig. 6.1

State the name of the distance labelled **A**.

..... [1]

- (b) Fig. 6.2 shows a glass measuring cylinder containing  $50.0 \text{ cm}^3$  of liquid at  $20^\circ\text{C}$ .

A student is using the thin converging lens as a magnifying glass to read the level of liquid on the scale.

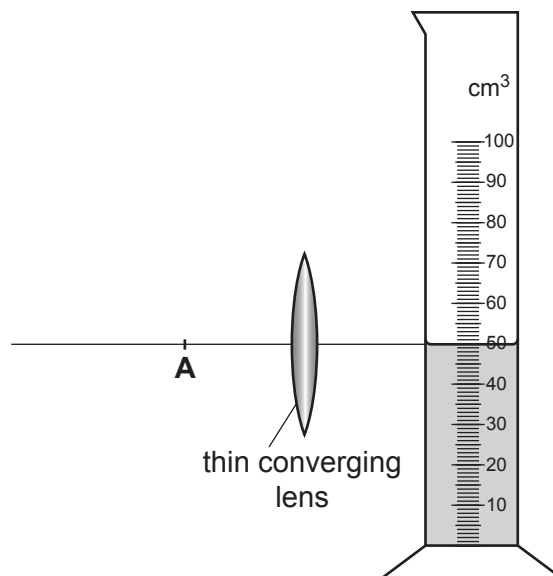

Fig. 6.2

- (i) On Fig. 6.2, mark with an **X** a point where the student positions her eye to see a magnified image of the level of the liquid on the scale. [1]
- (ii) The density of the liquid in the measuring cylinder is  $0.85 \text{ g/cm}^3$  at  $20^\circ\text{C}$ .

Calculate the mass of the liquid in the measuring cylinder.

mass = ..... g [2]

(c) The student increases the temperature of the liquid from 20 °C to 60 °C.

(i) Explain why the volume of the liquid increases as the temperature increases.

Use ideas about the distances between molecules and the motion of molecules in your answer.

.....  
.....  
.....  
..... [2]

(ii) State whether the density of the liquid increases or decreases.

Explain your answer.

density .....

explanation .....

..... [1]

[Total: 7]

- 7 (a) A study investigates the number of people with lung cancer in different age ranges.

Fig. 7.1 shows the results.

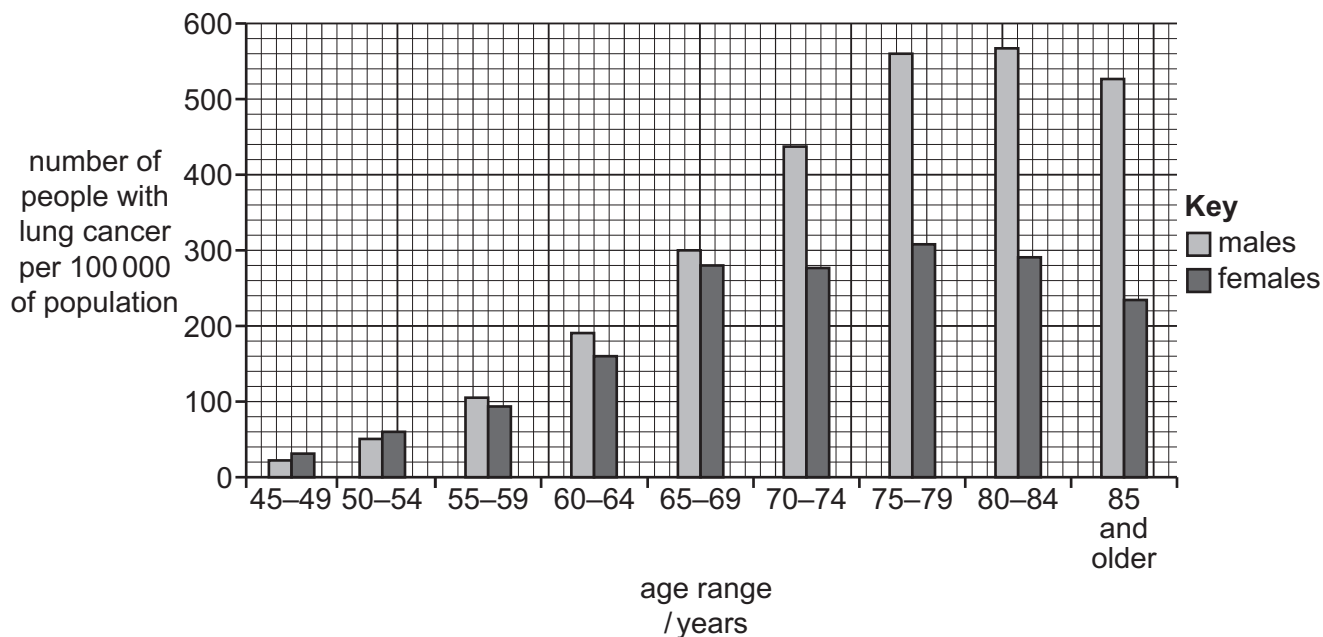

Fig. 7.1

- (i) Calculate the difference in the number of males and females with lung cancer in the 65–69-year-old age range.

..... per 100 000 of population [2]

- (ii) Lung cancer has been linked to tobacco smoke.

Complete these sentences about the three main toxic components of tobacco smoke.

The component most likely to cause lung cancer is .....

Carbon monoxide reduces the ability of red blood cells to transport .....

The addictive component of tobacco smoke is .....

[3]

- (b) The gas exchange surface in humans is alveoli.  
Fig. 7.2 shows healthy alveoli and alveoli damaged by tobacco smoke.

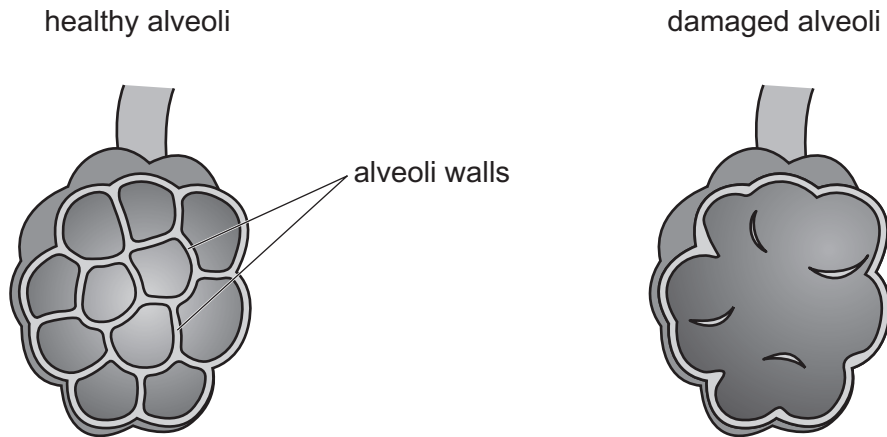

Fig. 7.2

A component in tobacco smoke breaks down the alveoli walls.

Use Fig. 7.2 to explain how tobacco smoke reduces gas exchange in the lungs.

.....

.....

..... [2]

[Total: 7]

- 8 Heptane,  $C_7H_{16}$ , is a hydrocarbon. It is used to produce smaller molecules, as shown in Fig. 8.1.

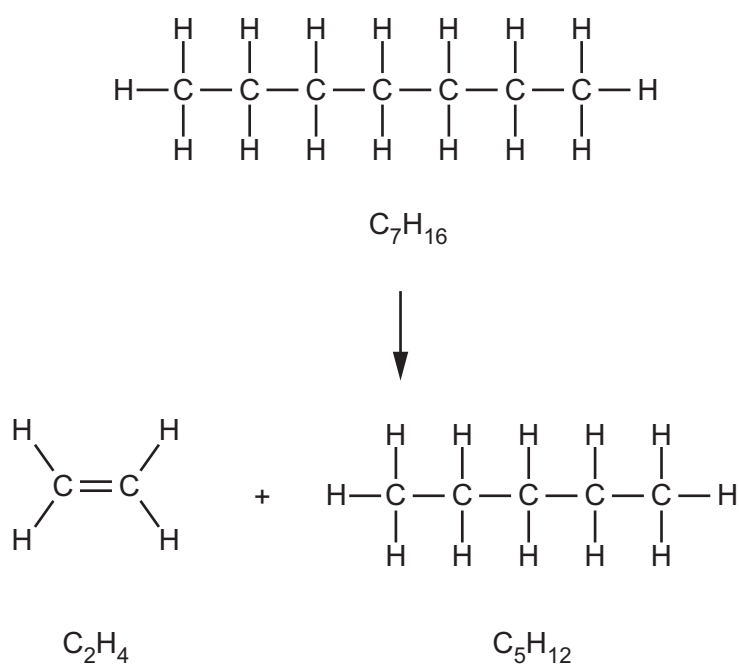

Fig. 8.1

- (a) (i) State the name of this process.

..... [1]

- (ii) State **two** conditions needed for this process.

1 .....

2 .....

[2]

- (b) Put ticks (✓) in the boxes to show which statements describe each compound.

Use Fig. 8.1 to help you.

You may tick one or more box in each row.

	compound		
	$C_7H_{16}$	$C_2H_4$	$C_5H_{12}$
It has molecules which contain 23 atoms.			
It is unsaturated.			
It is an alkane.			
It produces carbon dioxide and water when it burns.			

[3]



(c) Describe the colour change when aqueous bromine reacts with  $C_2H_4$ .

from ..... to ..... [1]

(d) The compound  $C_2H_4$  is a member of a homologous series.

Describe **two** similarities that are shared by all members of a homologous series.

1 .....

2 .....

[2]

[Total: 9]

9 Fig. 9.1 shows two lamps, **A** and **B**, used for lighting in a theatre.

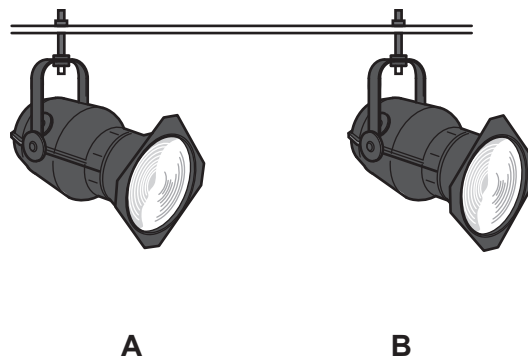

Fig. 9.1

Fig. 9.2 shows the circuit used for the two lamps.

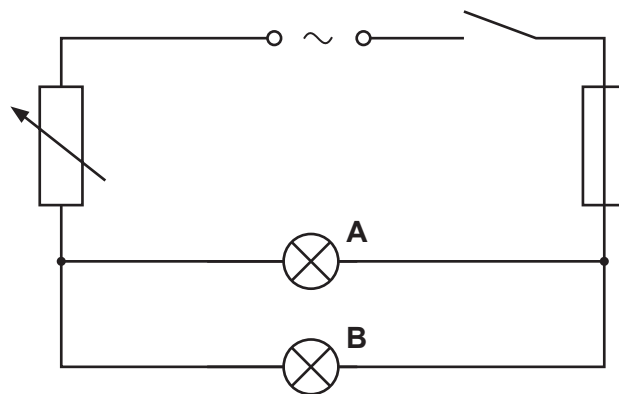
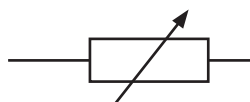

Fig. 9.2

(a) State the name and purpose of the component with the symbol shown.



name .....

purpose .....

.....

[2]

(b) The potential difference across the lamps is 220V.

The current in each lamp is 5.0A.

Calculate the combined resistance of lamps **A** and **B**.

resistance = .....  $\Omega$  [3]

(c) (i) During a performance in the theatre, the fuse blows and both lamps go out. There is no damage to the wiring and no short circuit.

The fuse in Fig. 9.2 has a rating of 10A.

Suggest what causes the fuse to blow.

Explain your answer.

.....  
.....  
..... [2]

(ii) Explain why 13A is a suitable rating for the replacement fuse.

.....  
.....  
..... [2]

(d) Lamp **A** emits infrared radiation and red visible light.

Lamp **B** emits blue visible light and ultraviolet radiation.

Fig. 9.3 shows an incomplete electromagnetic spectrum.

On Fig. 9.3, write infrared, ultraviolet and visible light in their correct places.

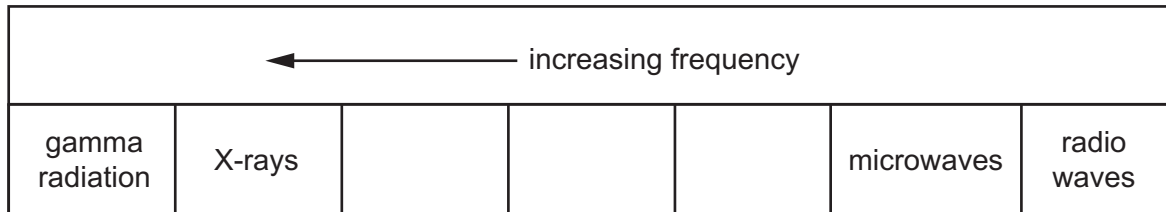

Fig. 9.3

[1]

[Total: 10]





**BLANK PAGE**

---

Permission to reproduce items where third-party owned material protected by copyright is included has been sought and cleared where possible. Every reasonable effort has been made by the publisher (UCLES) to trace copyright holders, but if any items requiring clearance have unwittingly been included, the publisher will be pleased to make amends at the earliest possible opportunity.

To avoid the issue of disclosure of answer-related information to candidates, all copyright acknowledgements are reproduced online in the Cambridge Assessment International Education Copyright Acknowledgements Booklet. This is produced for each series of examinations and is freely available to download at [www.cambridgeinternational.org](http://www.cambridgeinternational.org) after the live examination series.

Cambridge Assessment International Education is part of Cambridge Assessment. Cambridge Assessment is the brand name of the University of Cambridge Local Examinations Syndicate (UCLES), which is a department of the University of Cambridge.

## The Periodic Table of Elements

Group																	
I	II	III						IV	V	VI	VII	VIII					
3 <b>Li</b> lithium 7	4 <b>Be</b> beryllium 9	1 <b>H</b> hydrogen 1	5 <b>B</b> boron 11	13 <b>Al</b> aluminium 27	14 <b>C</b> carbon 12	15 <b>N</b> nitrogen 14	16 <b>O</b> oxygen 16	17 <b>F</b> fluorine 19	18 <b>Ne</b> neon 20	2 <b>He</b> helium 4							
11 <b>Na</b> sodium 23	12 <b>Mg</b> magnesium 24	<b>Key</b> atomic number atomic symbol name relative atomic mass															
19 <b>K</b> potassium 39	20 <b>Ca</b> calcium 40	21 <b>Sc</b> scandium 45	22 <b>Ti</b> titanium 48	23 <b>V</b> vanadium 51	24 <b>Cr</b> chromium 52	25 <b>Mn</b> manganese 55	26 <b>Fe</b> iron 56	27 <b>Co</b> cobalt 59	28 <b>Ni</b> nickel 59	29 <b>Cu</b> copper 64	30 <b>Zn</b> zinc 65	31 <b>Ga</b> gallium 70	32 <b>Ge</b> germanium 73	33 <b>As</b> arsenic 75	34 <b>Se</b> selenium 79	35 <b>Br</b> bromine 80	36 <b>Kr</b> krypton 84
37 <b>Rb</b> rubidium 85	38 <b>Sr</b> strontium 88	39 <b>Y</b> yttrium 89	40 <b>Zr</b> zirconium 91	41 <b>Nb</b> niobium 93	42 <b>Mo</b> molybdenum 96	43 <b>Tc</b> technetium —	44 <b>Ru</b> ruthenium 101	45 <b>Rh</b> rhodium 103	46 <b>Pd</b> palladium 106	47 <b>Ag</b> silver 108	48 <b>Cd</b> cadmium 112	49 <b>In</b> indium 115	50 <b>Sn</b> tin 119	51 <b>Sb</b> antimony 122	52 <b>Te</b> tellurium 128	53 <b>I</b> iodine 127	54 <b>Xe</b> xenon 131
55 <b>Cs</b> caesium 133	56 <b>Ba</b> barium 137	57–71 lanthanoids	72 <b>Hf</b> hafnium 178	73 <b>Ta</b> tantalum 181	74 <b>W</b> tungsten 184	75 <b>Re</b> rhenium 186	76 <b>Os</b> osmium 190	77 <b>Ir</b> iridium 192	78 <b>Pt</b> platinum 195	79 <b>Au</b> gold 197	80 <b>Hg</b> mercury 201	81 <b>Tl</b> thallium 204	82 <b>Pb</b> lead 207	83 <b>Bi</b> bismuth 209	84 <b>Po</b> polonium —	85 <b>At</b> astatine —	86 <b>Rn</b> radon —
87 <b>Fr</b> francium —	88 <b>Ra</b> radium —	89–103 actinoids	104 <b>Rf</b> rutherfordium —	105 <b>Db</b> dubnium —	106 <b>Sg</b> seaborgium —	107 <b>Bh</b> bohrium —	108 <b>Hs</b> hassium —	109 <b>Mt</b> meitnerium —	110 <b>Ds</b> darmstadtium —	111 <b>Rg</b> roentgenium —	112 <b>Cn</b> copernicium —	114 <b>Fl</b> flerovium —	116 <b>Lv</b> livermorium —				

lanthanoids

57 <b>La</b> lanthanum 139	58 <b>Ce</b> cerium 140	59 <b>Pr</b> praseodymium 141	60 <b>Nd</b> neodymium 144	61 <b>Pm</b> promethium —	62 <b>Sm</b> samarium 150	63 <b>Eu</b> europium 152	64 <b>Gd</b> gadolinium 157	65 <b>Tb</b> terbium 159	66 <b>Dy</b> dysprosium 163	67 <b>Ho</b> holmium 165	68 <b>Er</b> erbium 167	69 <b>Tm</b> thulium 169	70 <b>Yb</b> ytterbium 173	71 <b>Lu</b> lutetium 175
89 <b>Ac</b> actinium —	90 <b>Th</b> thorium 232	91 <b>Pa</b> protactinium 231	92 <b>U</b> uranium 238	93 <b>Np</b> neptunium —	94 <b>Pu</b> plutonium —	95 <b>Am</b> americium —	96 <b>Cm</b> curium —	97 <b>Bk</b> berkelium —	98 <b>Cf</b> californium —	99 <b>Es</b> einsteinium —	100 <b>Fm</b> fermium —	101 <b>Md</b> mendelevium —	102 <b>No</b> nobelium —	103 <b>Lr</b> lawrencium —

actinoids

The volume of one mole of any gas is 24 dm<sup>3</sup> at room temperature and pressure (r.t.p.).