



UNIVERSITY OF CAMBRIDGE INTERNATIONAL EXAMINATIONS  
International General Certificate of Secondary Education

CANDIDATE  
NAME

CENTRE  
NUMBER

--	--	--	--	--

CANDIDATE  
NUMBER

--	--	--	--

\* 6 6 0 8 4 8 0 6 7 0 \*

**CO-ORDINATED SCIENCES**

**0654/62**

Paper 6 Alternative to Practical

**October/November 2011**

**1 hour**

Candidates answer on the Question paper

No Additional Materials are required.

**READ THESE INSTRUCTIONS FIRST**

Write your Centre number, candidate number and name on all the work you hand in.

Write in dark blue or black pen.

You may use a soft pencil for any diagrams, graphs, tables or rough working.

Do not use staples, paper clips, highlighters, glue or correction fluid.

**DO NOT WRITE IN ANY BARCODES.**

Answer **all** questions.

At the end of the examination, fasten all your work securely together.

The number of marks is given in brackets [ ] at the end of each question or part question.

For Examiner's Use	
1	
2	
3	
4	
5	
6	
<b>Total</b>	

This document consists of **18** printed pages and **2** blank pages.



- 1 A student performed an experiment to investigate what affects the diffusion of acid into agar. Agar blocks of three different sizes (Fig. 1.1) were cut. The agar contained phenolphthalein indicator and alkali and so was pink in colour.

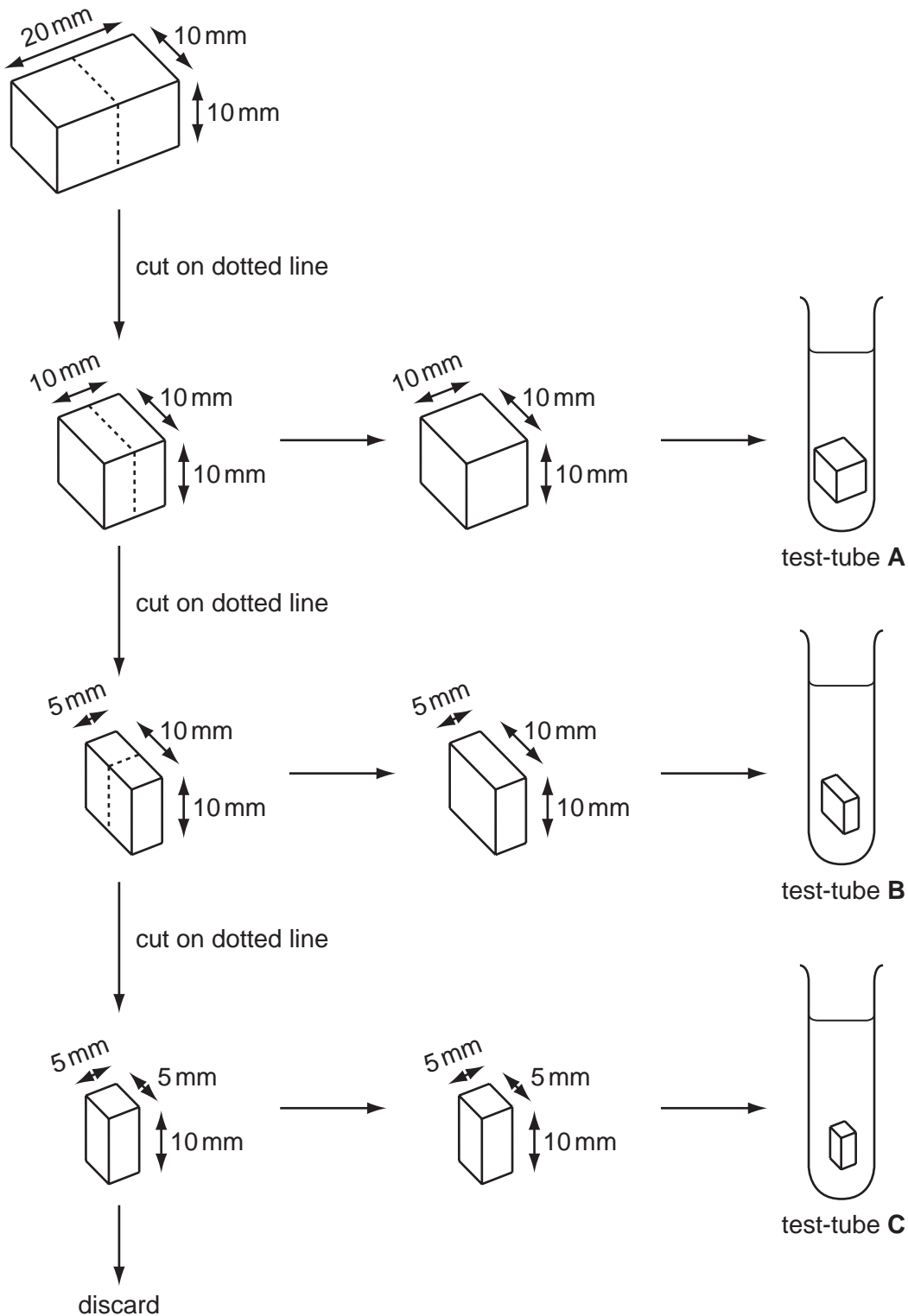

Fig 1.1

He placed each agar block into 20 cm<sup>3</sup> hydrochloric acid in separate test-tubes labelled **A**, **B** and **C**. The time taken for each block to become colourless (see Fig. 1.2) was then recorded. This is the point at which the acid reaches the centre of the block (Fig. 1.3).

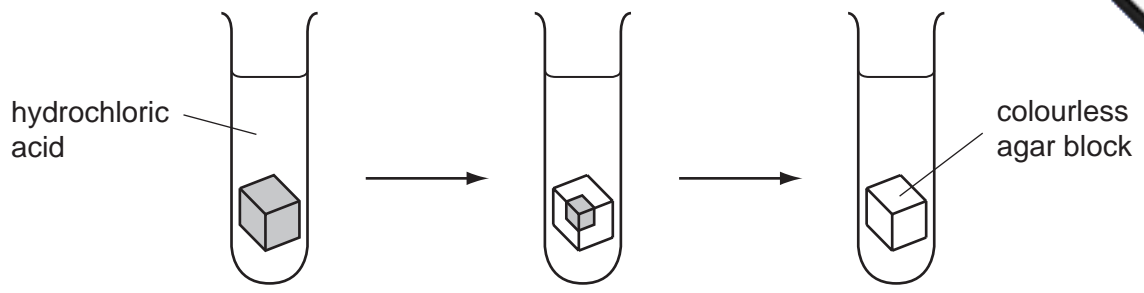

Fig. 1.2



test-tube A

test-tube B

test-tube C

Fig. 1.3

(a) (i) Use the stopclocks shown in Fig. 1.3 to record, in Table 1.1, the times taken, in **seconds**, for the blocks to become colourless. [2]

Table 1.1

tube	A	B	C
cube dimensions/mm	10 x 10 x 10	10 x 10 x 5	10 x 5 x 5
volume of block/mm <sup>3</sup>	1000	500	250
surface area of block/mm <sup>2</sup>	600	400	250
surface area/volume ratio			
time taken for block to go colourless/s			

(ii) Explain why the blocks go colourless.

.....

.....

.....

[2]

- (iii) Calculate the surface area : volume ratio for each block using the formula and record them in Table 1.1.

$$\text{ratio} = \frac{\text{surface area of block/mm}^2}{\text{volume of block/mm}^3}$$

[1]

- (iv) Explain the effect that decreasing the volume of the blocks has on the time taken for the blocks to become colourless.

.....

.....

.....

..... [2]

- (b) Fig. 1.4 shows a cross section through the human ileum and a magnified image of one villus.

Using your answer to (a)(iv) and your own knowledge, explain how rapid diffusion of substances into the blood is ensured by the structure of the ileum and villi.

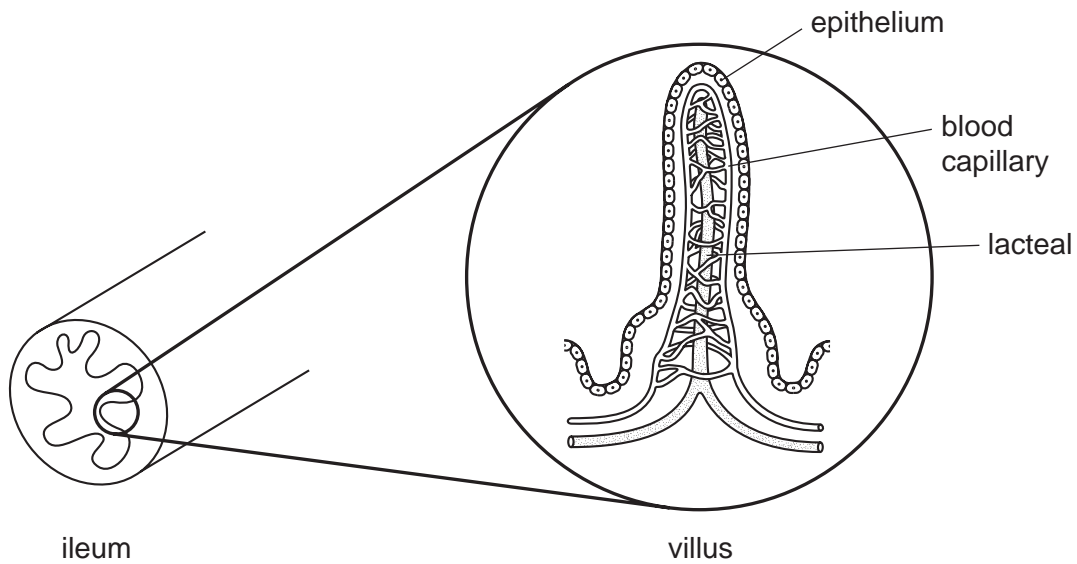

Fig. 1.4

.....

.....

.....

..... [3]



**Please turn over for Question 2.**

2 A student carries out the following tests on solid **X**, which contains two metal salts.

Complete Table 2.1, which shows the tests on solid **X** and the student's observations and conclusions.

**Table 2.1**

test	observation	conclusion
<b>(a)</b> Mix one spatula full of solid <b>X</b> with solid calcium hydroxide in a test-tube. Heat gently.		
<b>(i)</b> Test the gas with moist red litmus paper.	..... ..... [1]	ammonia gas is given off
<b>(ii)</b> Hold a glass rod dipped in concentrated hydrochloric acid in the gas.	white smoke	..... ..... [1] is formed.
<b>(b)</b> Prepare a dilute solution of <b>X</b> in distilled water.		
<b>(i)</b> To a portion of the solution of <b>X</b> , add dilute sodium hydroxide until there is no further reaction.	..... ..... ..... [2]	solid <b>X</b> contains zinc ions
<b>(ii)</b> Acidify a fresh portion of the solution of <b>X</b> with dilute nitric acid, then add barium chloride solution.	white precipitate	..... ..... ..... [1]
<b>(iii)</b> Acidify a fresh portion of the solution of <b>X</b> with dilute nitric acid, then add silver nitrate solution. Allow the tube to stand in bright sunlight.	white precipitate which turns ..... [1]	..... ..... ..... [1]

(c) Suggest the names of **two** salts that may be contained in solid X.

1 .....

2 .....

[2]

(d) Write a balanced symbol equation for the chemical reaction seen in test (a)(ii).

.....

[1]

- 3 When a light ray passes through a rectangular glass block, the ray is displaced from its original path onto a new path. This is shown in Fig. 3.1.

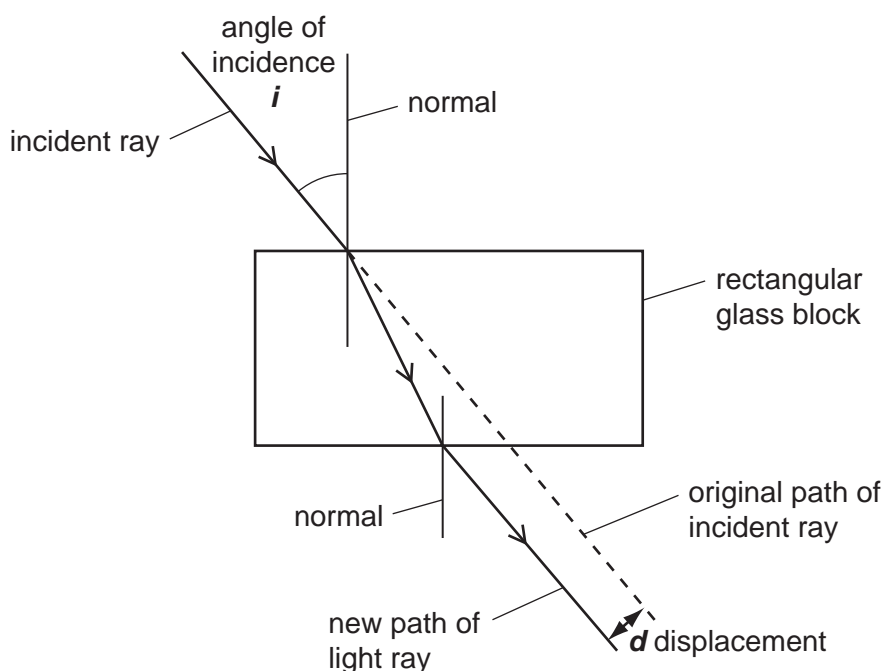

**Fig. 3.1**

A student is doing an experiment to find out how the value of the displacement distance,  $d$ , varies with  $i$ , the angle of incidence.

- He places a glass block on a sheet of paper and draws the outline of the block on it.
- He shines a narrow beam of light through the glass block.
- He marks the path of the incident ray on the paper.
- He measures  $i$ , the angle of incidence, and records the value in Table 3.1.
- He marks the new path of the light ray on the opposite side of the block.
- He removes the glass block from the paper and extends the line showing the original path of the light ray.
- He measures the displacement distance,  $d$ , shown in Fig. 3.1, to the nearest millimetre and records it in Table 3.1.
- He repeats the experiment, each time using a different angle of incidence, and records the results in Table 3.1.

**Table 3.1**

experiment number	1	2	3	4	5
angle of incidence, $i/^\circ$	15	28	46		77
displacement, $d/\text{mm}$	5	11	20		47



(a) Fig. 3.2 shows his diagram for experiment 4.

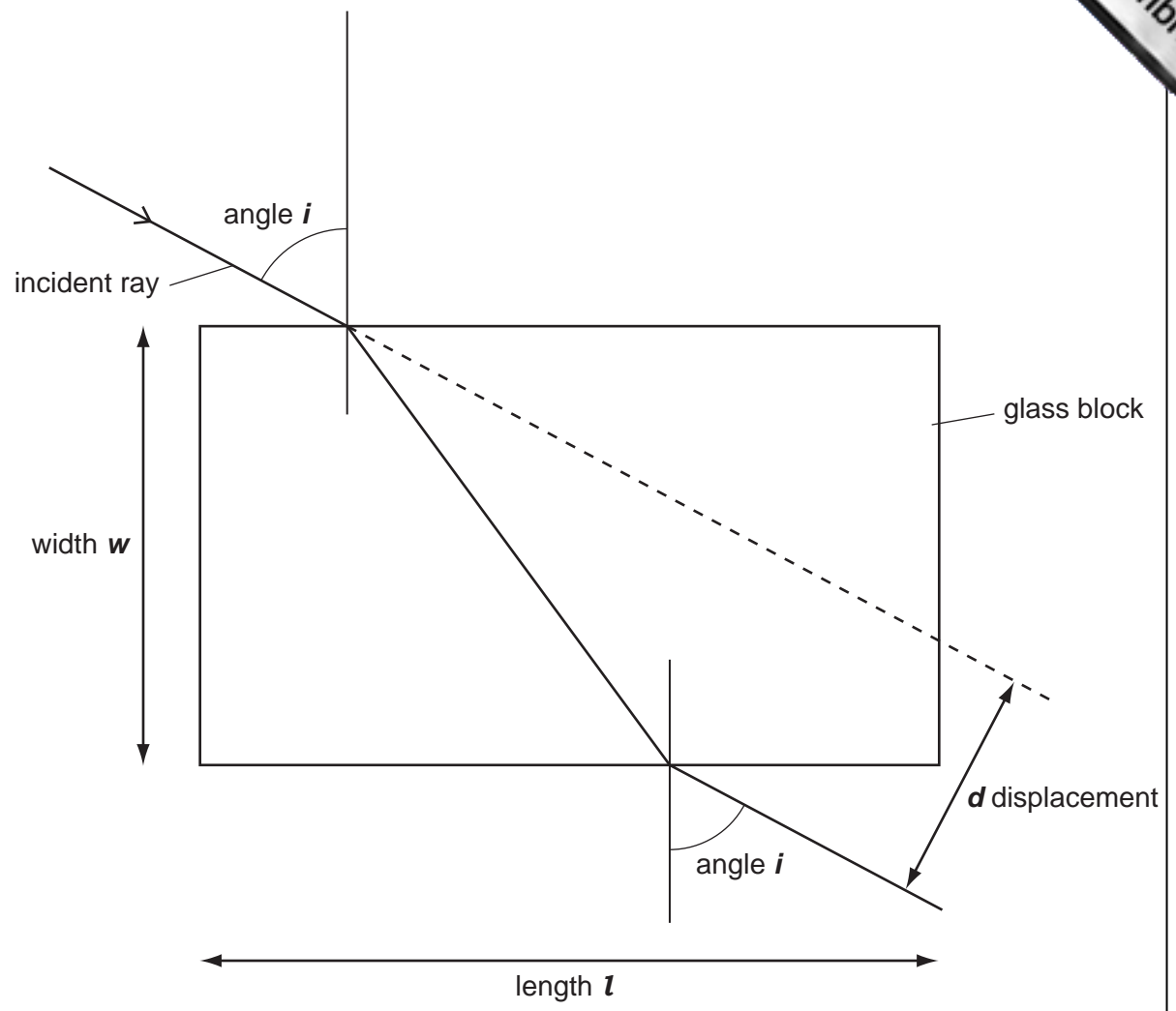

Fig. 3.2

- (i) On Fig. 3.2, measure  $i$ , the angle of incidence, to the nearest degree. Record it in Table 3.1. [1]
- (ii) On Fig. 3.2, measure the displacement distance,  $d$ , in millimetres to the nearest millimetre, and record it in Table 3.1. [1]
- (iii) On Fig. 3.2, measure the length,  $l$ , and the width,  $w$ , of the glass block in millimetres to the nearest millimetre.

$l =$  ..... mm

$w =$  ..... mm [2]

- (b) (i) On the graph grid provided, plot a graph of the displacement distance,  $d$ , (y-axis) in millimetres against the angle of incidence,  $i$ . Use values of  $i$  from 0 to 90° and values of  $d$  from 0 to 80 mm.

Draw a smooth curve through the points and extend the line to the point  $i = 90^\circ$ .

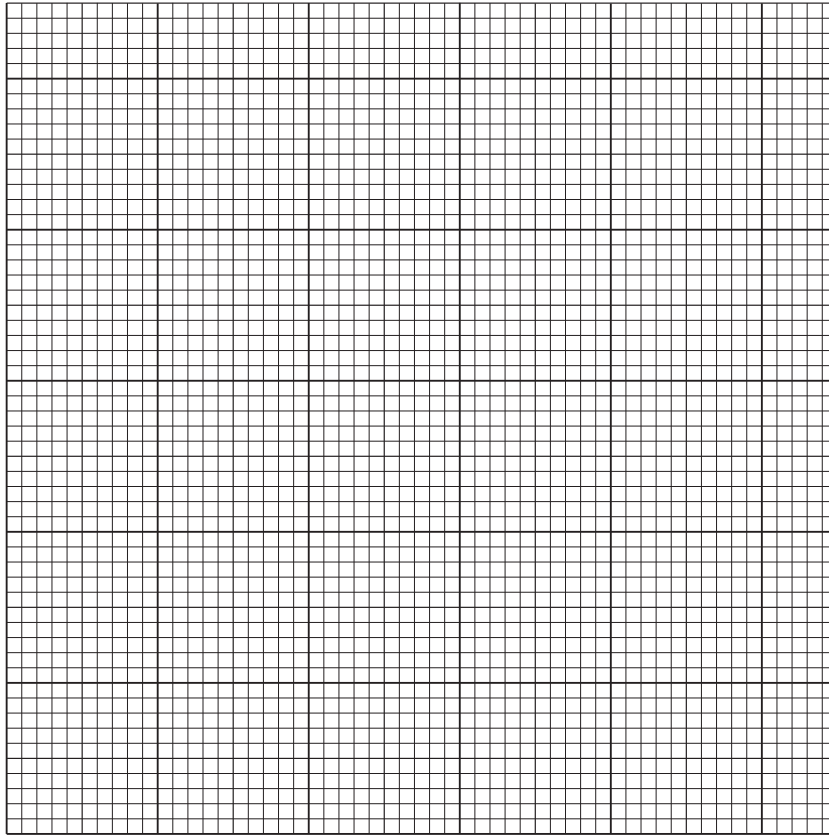

[3]

- (ii) Use your graph to find the value of the displacement distance,  $d_{90}$ , when the angle of incidence is  $90^\circ$ .

Show how you do this on the graph.

$d_{90} = \dots\dots\dots$  mm [2]

(c) Compare your answers to parts (a)(iii) and (b)(ii).

Complete this sentence.

**“In theory, if the angle of incidence of a light ray passing through a rectangular glass block is equal to 90 degrees, the displacement distance is equal to the**

**..... of the block.”**

[1]

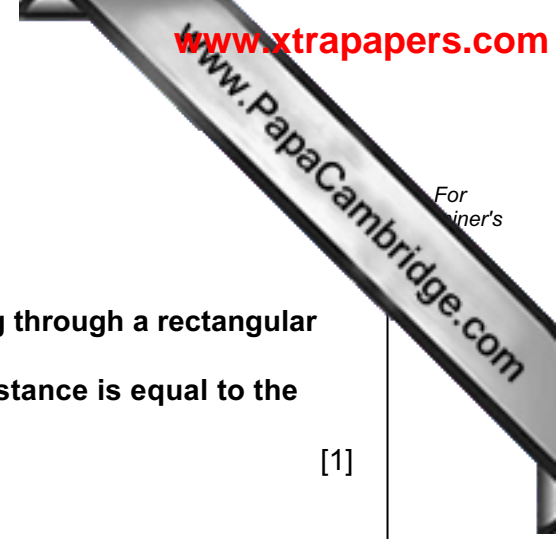

- 4 (a) A student was studying cells under a microscope. She prepared cells from epidermis, placed them onto a slide and stained them using iodine solution.

The student wanted to measure the average length of epidermis cells. She placed a ruler with a millimetre scale on the stage of the microscope to find the diameter of the field of view. She looked down the microscope and saw the field of view in Fig. 4.1.

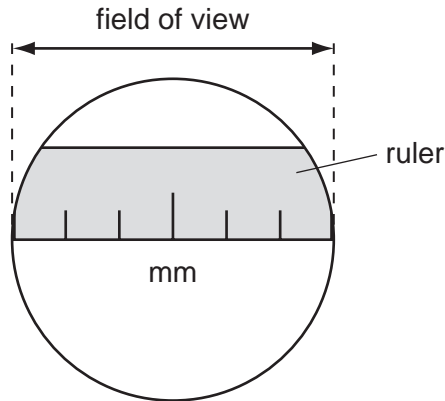

Fig. 4.1

- (i) How wide is the field of view of the microscope? ..... mm [1]
- (ii) The student removed the ruler and placed her slide under the microscope. She counted 15 cells end to end across the field of view.

Use your answer to (a)(i) to calculate the average length of an onion cell.

Show your working.

length of cell ..... mm [2]

- (b) A group of cells is shown in Fig. 4.2.

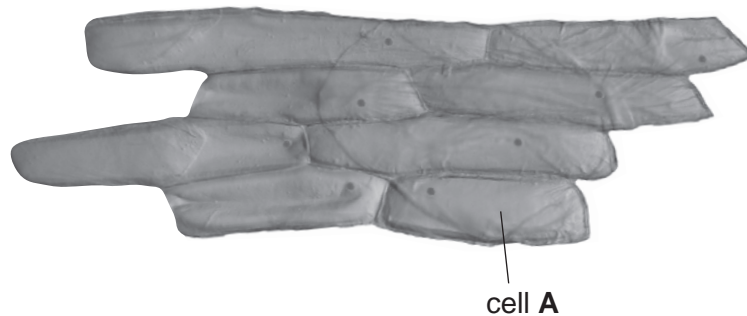
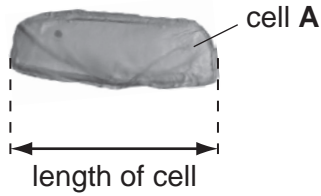

Fig. 4.2

- (i) Make a large drawing of cell **A** in the space provided. Label the nucleus and cell wall.

[1]

- (ii) Measure the length of cell **A** on **your** diagram at the longest part. See Fig. 4.3.



**Fig. 4.3**

length of cell **A** on **my** diagram ..... mm

Using the value for the average cell length from **(a)(ii)** and the length of cell **A** on your diagram, calculate the magnification of your drawing.

magnification = ..... [3]

(c) The student looked at a diagram of a plant cell in a text book. This cell came from a leaf. It is shown in Fig. 4.4.

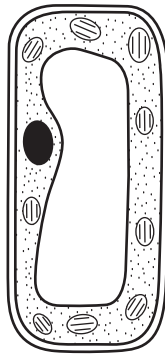

Fig. 4.4

(i) Label **one** structure on Fig. 4.4 that is **not present** in onion epidermis cells. [1]

(ii) Suggest a reason why this structure is missing from onion epidermis cells.

.....

..... [1]

(iii) Label **one** structure on Fig. 4.4 that is present in onion epidermis cells but **not** visible in Fig. 4.2 or Fig. 4.3. [1]



**Please turn over for Question 5.**

5 The science teacher has asked the class to plan an experiment to compare the amount of citric acid in an orange, a lemon and a grapefruit. The acid in these fruits is citric acid.

The students have made a list of the steps in the experiment.

- Cut the orange with a knife and squeeze out the juice.
- Filter the juice and place it in a conical flask.
- Add a few drops of indicator.
- Add sodium hydroxide solution from a burette until the indicator changes colour.
- Note the volume of sodium hydroxide solution used.
- Repeat the steps above using a lemon and a grapefruit.

(a) (i) Name an indicator suitable to use in this experiment and give its colours in acid and in alkali.

name of indicator ..... [1]

colour in acid ..... [1]

colour in alkali ..... [1]

(ii) Suggest the name of the salt formed when citric acid reacts with sodium hydroxide.  
..... [1]

(b) The students carry out the experiment. Table 5.1 shows the results.

Table 5.1

juice	orange	lemon	grapefruit
first burette reading / cm <sup>3</sup>	0	0.8	4.7
second reading / cm <sup>3</sup>			
volume added / cm <sup>3</sup>			



(i) Fig. 5.1 shows the burette scales for the second readings. Read the burette and record the results in Table 5.1.

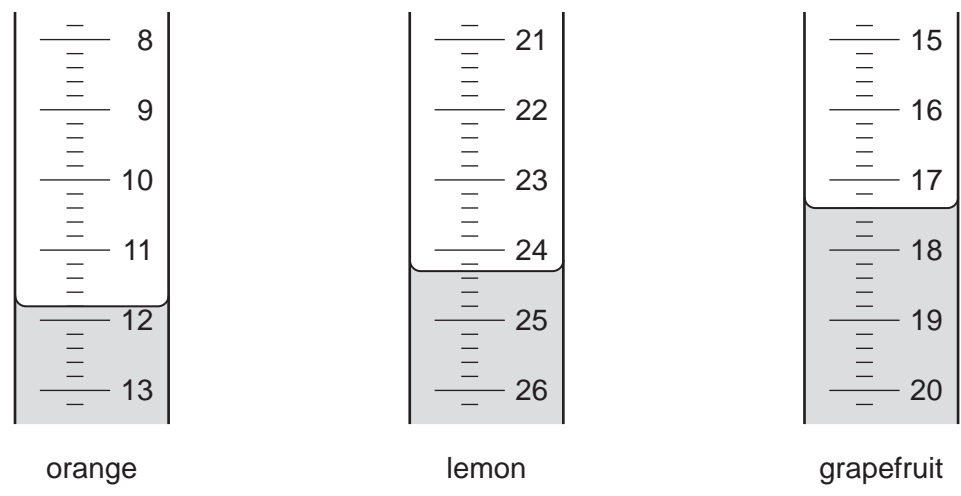

second readings of burette

Fig. 5.1

(ii) Complete Table 5.1 to show the volumes of sodium hydroxide added. [1]

(iii) List the three fruits in order of the amount of acid they contain, with the fruit containing the most acid first.

1 (most acid) .....

2 .....

3 (least acid) ..... [1]

(c) Suggest **two** ways in which this experiment must be modified so that the concentration of acid in the fruit juices may be measured, assuming that the same kind of acid is contained in each fruit.

1 .....

2 .....

[2]

6 The teacher is showing the class an apparatus for investigating the expansion of metals. For  
 A metal bar is heated to a known temperature to find the increase in its length. Fig. 6.1  
 shows the apparatus.

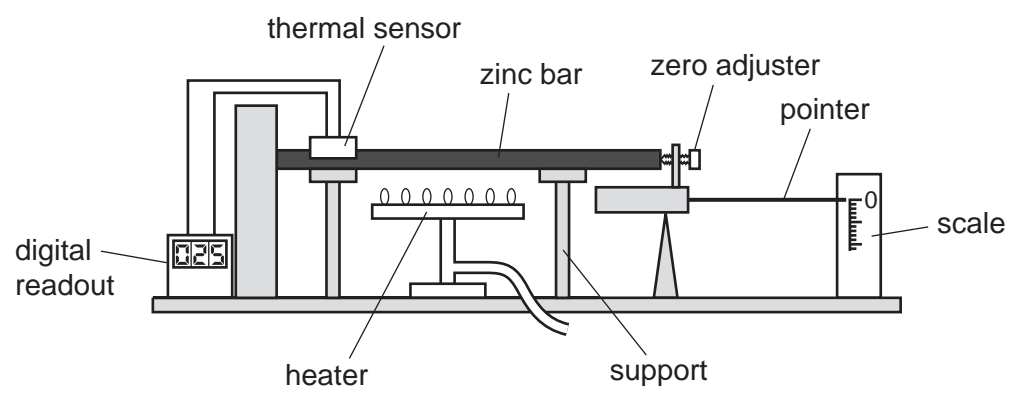

Fig. 6.1

Fig. 6.2 shows how the pointer measures the increase in length of the bar.

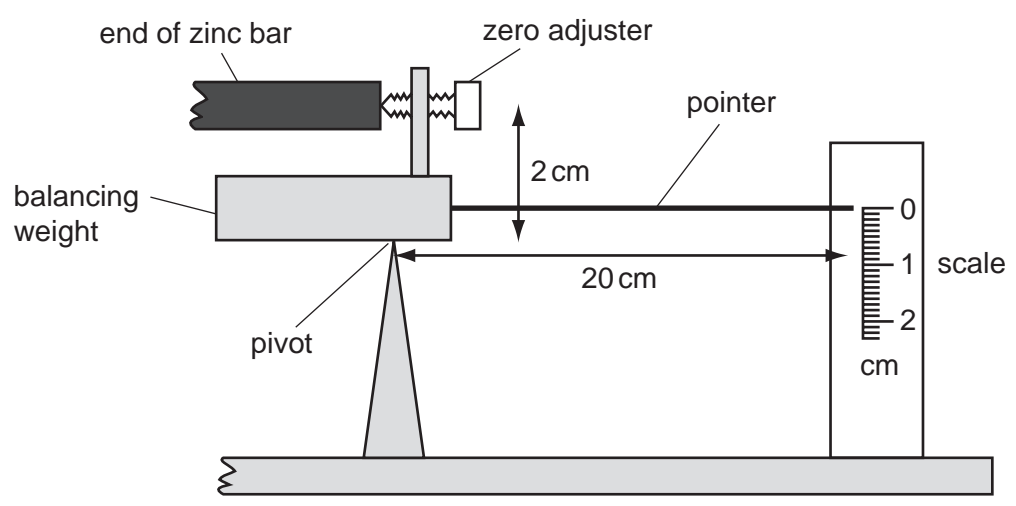

Fig. 6.2

- The teacher places a zinc bar of length 20 centimetres on the supports.
- He adjusts the pointer until the scale reads 0 cm.
- He slowly heats the bar until the thermal sensor reads 300 °C.
- He reads the position of the pointer on the scale and records it in Table 6.1.
- He repeats the experiment with bars of three other metals.

Table 6.1

metal	zinc	iron	aluminium	copper
pointer reading / cm	1.8			
expansion / mm				

(a) The pointer and scale for the metals iron, aluminium and copper are shown in Fig. 6.3. For pointer's  
 Read the scales. In Table 6.1, record the readings in centimetres to the nearest millimetre. [3]

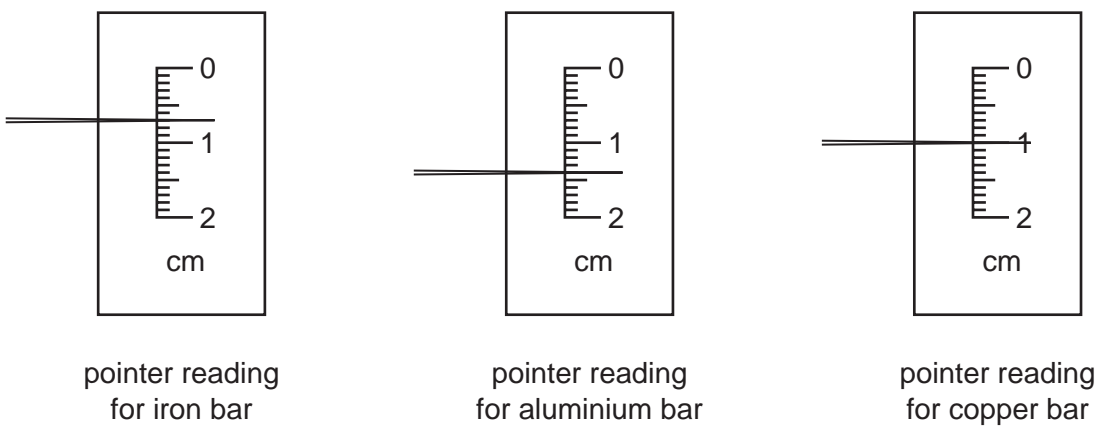

Fig. 6.3

(b) (i) Explain why the expansion of the bar is found by dividing the pointer reading by 10. Use Fig. 6.2 to help you.

.....  
 .....  
 ..... [2]

(ii) Calculate the expansion of the bars in millimetres and complete Table 6.1.

[1]

(c) Use the data in Table 6.1 and place the metals in order of the amount that they expanded.

1 (most expansion) .....  
 2 .....  
 3 .....  
 4 (least expansion) .....

[1]

(d) Fig.6.4 shows atoms in a solid metal.

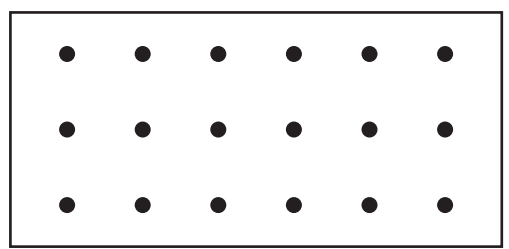

Fig. 6.4

(i) Describe the motion of the atoms in a solid metal. You may draw on Fig. 6.4 to help your description.

.....  
..... [1]

(ii) Explain why heating the metal causes it to expand.

.....  
.....  
..... [2]