



UNIVERSITY OF CAMBRIDGE INTERNATIONAL EXAMINATIONS  
International General Certificate of Secondary Education

**CO-ORDINATED SCIENCES**

**0654/52**

Paper 5 Practical Test

**October/November 2012**

CONFIDENTIAL INSTRUCTIONS

**Great care should be taken to ensure that any confidential information given does not reach the candidates either directly or indirectly.**

**The Supervisor's attention is drawn to the form on page 8 which must be completed and returned with the scripts.**

If you have any queries regarding these instructions, please contact CIE  
by e-mail: [International@cie.org.uk](mailto:International@cie.org.uk)  
by phone: +44 1223 553554  
by fax: +44 1223 553558  
stating the nature of the query and the syllabus number quoted above.

\* 5 2 9 9 9 7 4 6 7 6 \*

This document consists of **8** printed pages.



## Instructions for preparing apparatus

These instructions detail the apparatus, reagents and specimens required by each candidate for the experiment in this paper. A summary of the questions that will be presented to the candidates is included, where appropriate, to allow the teacher to test the apparatus appropriately. **No access is permitted to the question paper in advance of the examination session.**

It is assumed that the ordinary apparatus of a science laboratory will be available, including a supply of purified water (distilled or deionised).

If arrangements are made for different sessions for different groups of candidates, care must be taken to ensure that the different groups of candidates are effectively isolated so that **no information passes between them.**

**All specimens should carry only the code letters and numbers as indicated and their identity should not be revealed to the candidates.**

Supervisors should ensure that all specimens have the correct identity attached to the specimen and that these are **not** removed during the examination.

If a candidate breaks any of the apparatus, or loses any of the material supplied, the matter should be rectified and a note made in the Supervisor's Report.

Supervisors are advised to remind candidates that **all** substances in the examination should be treated with caution. Only those tests described in the Question Paper should be attempted. Pipette fillers and safety goggles should be used where necessary.

In accordance with COSHH (Control of Substances Hazardous to Health) Regulations, operative in the UK, a hazard appraisal of the examination has been carried out.

The following codes are used where relevant.

**C** = corrosive substance

**F** = highly flammable substance

**H** = harmful or irritating substance

**O** = oxidising substance

**T** = toxic substance

**N** = harmful to the environment

The attention of Centres is drawn to any local regulations relating to safety, first-aid and disposal of chemicals.

'Hazard Data Sheets', relating to materials used in this examination, should be available from your chemical supplier.

The Supervisor should make sure the Supervisor's Report is fully completed and a copy is enclosed with each packet of scripts.

Centres are reminded that they are **not** permitted to open the question paper envelopes before the examination. Centres are also referred to the Handbook for Centres, and in particular Section 3.1.2(c)(i), Security of Question Papers and Examination Materials, as well as 3.3.11.1, Practical Examinations in Science Subjects.

If there are difficulties with any aspect of setting up this practical examination that the Centre is not able to resolve, it is essential, for Centres to contact the Product Manager as soon as possible by e-mail to [international@cie.org.uk](mailto:international@cie.org.uk), by phone to +44 1223 553554 or by fax to +44 1223 553558.

**For Question 1**

Each candidate will require:

- (i) two containers (e.g. petri dishes), with lids, labelled **A** and **B**, each containing three freshly-picked leaves of the same species, as below:

Dish **A**, containing three dicotyledonous leaves including petiole: e.g. holly, geranium

Dish **B**, containing three monocotyledonous leaves at least 5mm in width: e.g. iris, large grass

- (ii) Bunsen burner\*
- (iii) heatproof mat\*
- (iv) tripod\*
- (v) gauze\*
- (vi) 400 cm<sup>3</sup> beaker and water to half-fill it\*
- (vii) thermometer
- (viii) a pair of tweezers
- (ix) a 30 cm ruler, graduated in mm.

\*Note: If Bunsen burners etc. are not available, a water bath at a temperature of 80–100 °C can be provided instead.

**Candidates should be allowed to have extra leaves if requested, without penalty.**

**For Question 2**

Each candidate will require:

- (i) 2 smooth rods or pulleys (no more than 1 cm in diameter)
- (ii) 2 stands and clamps to hold rods or pulleys (see Fig. 2.1)

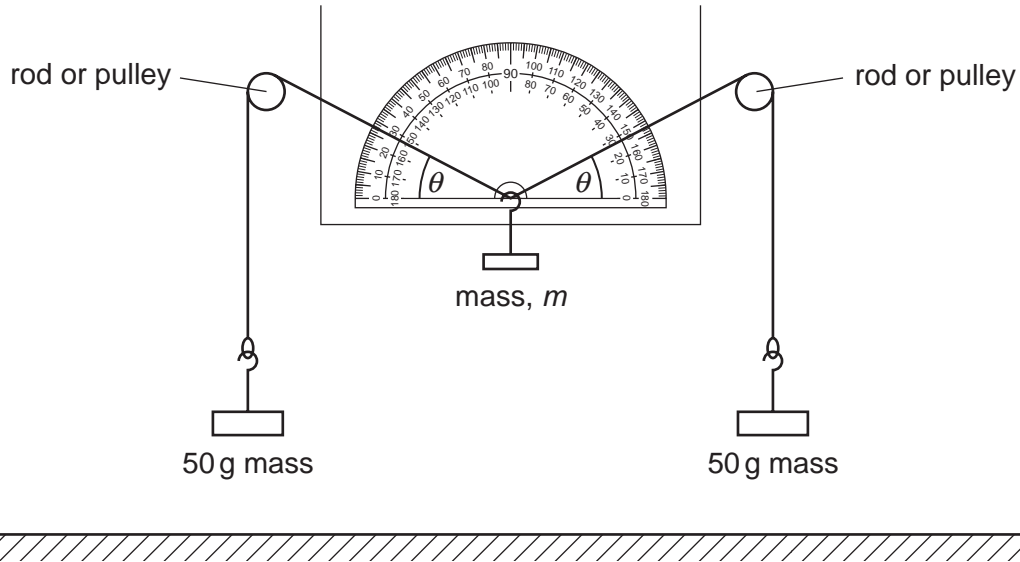

**Fig. 2.1**

The candidate will be required to assemble the apparatus as shown in Fig. 2.1.

- (iii) a 30 cm ruler
- (iv) 2 x 50 g masses attached to either end of 60 cm of thread
- (v) 10 g mass which could be a 10 g hanger, labelled 10 g
- (vi) if the 10 g mass is not a hanger, some means of suspending masses from the middle of the arrangement (see Fig. 2.1)
- (vii) sufficient masses to produce total masses,  $m$ , of 20, 40, 60 and 80 g, labelled with their masses
- (viii) a copy of one of the protractors on page 6 stuck to a piece of stiff A6 card.

**For Question 3**

Each candidate will require:

- [H]** (i) about 10 cm<sup>3</sup> dilute hydrochloric acid, about 2 mol dm<sup>-3</sup>, labelled **dilute hydrochloric acid**
- Note: Add 1-2 drops of copper sulfate (0.5 mol dm<sup>-3</sup>) to the acid so that it is not obviously blue.
- [F]** (ii) about 2.5 g zinc powder, labelled **A**
- Note: A spatula load of **A** and half a test-tube of 2 mol dm<sup>-3</sup> hydrochloric acid must produce enough hydrogen in 1 minute for positive testing
- [H]** (iii) about 30 cm<sup>3</sup> of 0.5 mol dm<sup>-3</sup> aqueous iron(III) chloride, labelled **B**
- (iv) 5 test-tubes, approximately 125 x 15 mm
- (v) stopper to fit a test-tube in (iv)
- (vi) 1 large test-tube, approximately 150 x 25 mm
- (vii) stopper to fit large test-tube in (vi)
- (viii) spatula
- [H]** (ix) about 20 cm<sup>3</sup> aqueous sodium hydroxide, 0.4 mol dm<sup>-3</sup>, labelled **aqueous sodium hydroxide**
- [N][H]** (x) about 5 cm<sup>3</sup> aqueous silver nitrate, 0.05 mol dm<sup>-3</sup>, labelled **aqueous silver nitrate**
- (xi) about 5 cm<sup>3</sup> aqueous barium chloride, 0.1 mol dm<sup>-3</sup>, labelled **aqueous barium chloride**
- (xii) access to a Bunsen burner or means of lighting a splint
- (xiii) wooden splint
- (xiv) 3 dropper pipettes (5 ml) to transfer liquids in (ix), (x) and (xi). Alternatively, these liquids may be presented in labelled dropper bottles.

**Candidates should be allowed extra chemicals if requested, without penalty.**

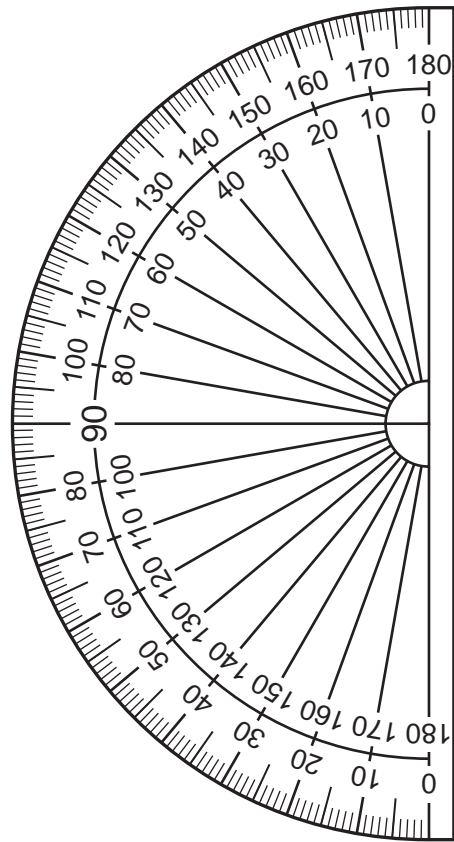
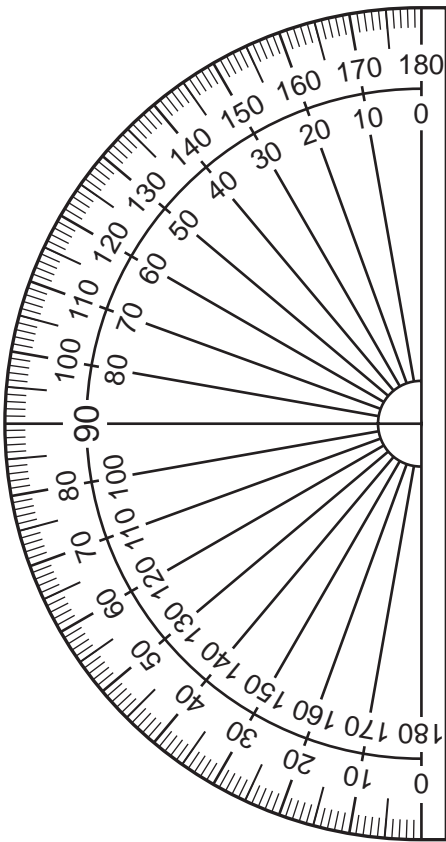
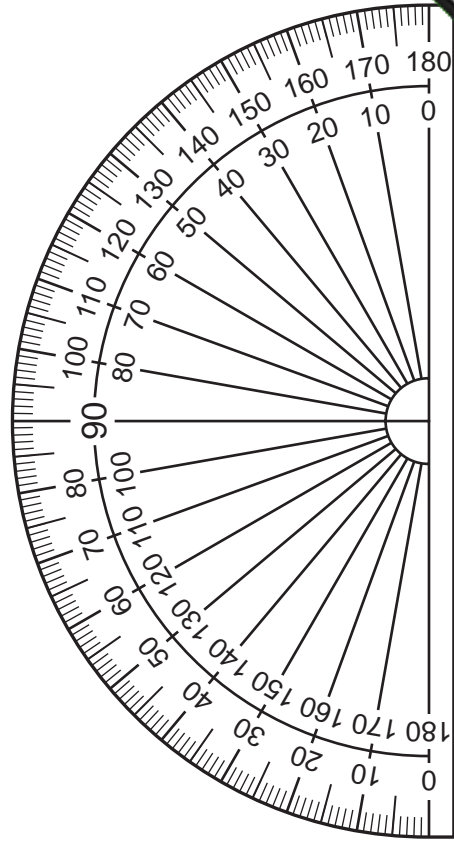
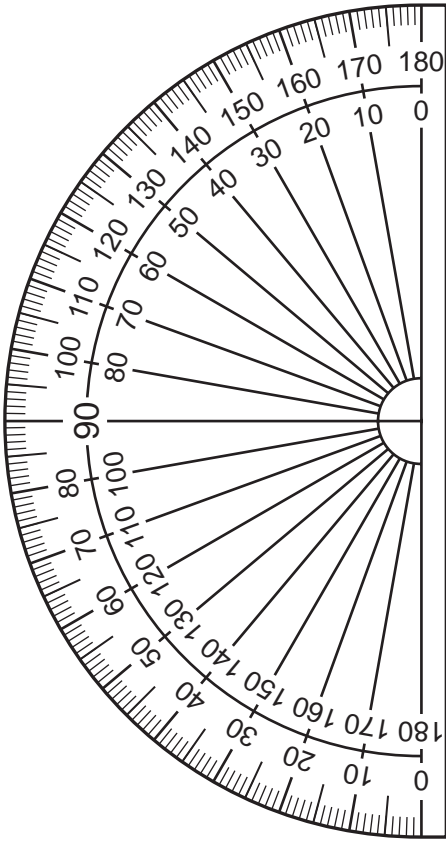

Spare materials and equipment should be available and can be provided without penalty. **Candidates should be made aware of this.**

*Information required from the Supervisor:*

**The Supervisor is asked to carry out the experiments and to enter the results on a spare copy of the examination paper, clearly marked 'Supervisor's Results' and showing the Centre number. This should be done, out of sight of the candidates, using the same solutions, reagents, specimens and apparatus as the candidates.**

**A copy of the 'Supervisor's Results' should be returned with each packet of scripts. Failure to do so may cause the candidates to be penalised.**

This form must be completed and returned in the envelope with the scripts together with the seating plan and the Supervisor's Results as mentioned on page 7.

October/November 2012

General

The Supervisor is invited to give details of any difficulties experienced by particular candidates giving their names and candidate numbers. These should include reference to:

- (a) difficulties due to faulty apparatus;
- (b) accidents to apparatus or materials;
- (c) physical handicaps, e.g. short sight, colour blindness;
- (d) any other information that is likely to assist the Examiner, especially if this cannot be discovered in the scripts;
- (e) any help given to a candidate.

The Supervisor is asked to supply the following information:

Plan of work benches, giving details by candidate numbers of the places occupied by the candidates for each session and a copy of the 'Supervisor's Results'.

NAME OF CENTRE .....

SIGNED .....

Supervisor

CENTRE NUMBER .....

DECLARATION (to be signed by the Principal)

The preparation of this practical examination has been carried out so as to maintain fully the security of the examination.

NAME .....  
(in block capitals)

SIGNED ..... (Principal)

