



Cambridge International Examinations
Cambridge International General Certificate of Secondary Education

CO-ORDINATED SCIENCES

0654/52

Paper 5 Practical Test

October/November 2014

CONFIDENTIAL INSTRUCTIONS

Great care should be taken to ensure that any confidential information given does not reach the candidates either directly or indirectly.

The Supervisor's attention is drawn to the form on page 8 which must be completed and returned with the scripts.

If you have any queries regarding these instructions, please contact CIE

by e-mail: info@cie.org.uk

by phone: +44 1223 553554

by fax: +44 1223 553558

stating the nature of the query and the syllabus number quoted above.

This document consists of 7 printed pages and 1 blank page.

Instructions for preparing apparatus

These instructions detail the apparatus, reagents and specimens required by each candidate for each experiment in this paper. A summary of the questions that will be presented to the candidates is included, where appropriate, to allow the teacher to test the apparatus appropriately. **No access is permitted to the question paper in advance of the examination session.**

It is assumed that the ordinary apparatus of a science laboratory will be available, including a supply of purified water (distilled or deionised).

If arrangements are made for different sessions for different groups of candidates, care must be taken to ensure that the different groups of candidates are effectively isolated so that **no information passes between them.**

All specimens should carry only the code letters and numbers as indicated and their identity should not be revealed to the candidates.

Supervisors should ensure that all specimens have the correct identity attached to the specimen and that these are **not** removed during the examination.

If a candidate breaks any of the apparatus, or loses any of the material supplied, the matter should be rectified and a note made in the Supervisor's Report.

Supervisors are advised to remind candidates that **all** substances in the examination should be treated with caution. Only those tests described in the Question Paper should be attempted. Pipette fillers and safety goggles should be used where necessary.

In accordance with COSHH (Control of Substances Hazardous to Health) Regulations, operative in the UK, a hazard appraisal of the examination has been carried out.

The following codes are used where relevant.

C = corrosive substance

F = highly flammable substance

H = harmful or irritating substance

O = oxidising substance

T = toxic substance

N = harmful to the environment

The attention of Centres is drawn to any local regulations relating to safety, first-aid and disposal of chemicals.

'Hazard Data Sheets', relating to materials used in this examination, should be available from your chemical supplier.

The Supervisor should make sure the Supervisor's Report is fully completed and a copy is enclosed with each packet of scripts.

Centres are reminded that they are **not** permitted to open the question paper envelopes before the examination. Centres are also referred to the Handbook for Centres, the Security of Question Papers and Examination Materials section and the Practical Examinations in Science Subjects section.

If there are difficulties with any aspect of setting up this practical examination that the Centre is not able to resolve, it is essential, for Centres to contact the Product Manager as soon as possible by e-mail to info@cie.org.uk, by phone to +44 1223 553554 or by fax to +44 1223 553558.

For Question 1

Each candidate will require

- (i) 2 clean test-tubes size approx. 125 x 15 mm
- (ii) 1 spotting tile with at least 10 wells
- (iii) some means of labelling the test-tubes and spotting tile e.g. chinagraph pencil
- (iv) 25 cm³ 1% starch solution, labelled **starch solution**
- (v) water-bath at approximately 30 °C, with support for test-tubes
- (vi) 5 cm³ 1% amylase solution, in a test-tube labelled **C**
- (vii) 5 cm³ 1% boiled amylase solution, in a test-tube labelled **D**
- (viii) stopclock or a timer on which candidates can easily read seconds
- (ix) iodine solution, with a dropping pipette, labelled **iodine solution**
- (x) 2 dropping pipettes
- (x) 10 cm³ measuring cylinder
- (xi) distilled water for rinsing and beaker for the waste water
- (xii) test-tube rack.

Note: The supervisor must check prior to the exam that the amylase to be used will break down the starch solution within 10 minutes and that the boiled amylase will not break down the starch solution.

For Question 2

Each candidate will require

- (i) 1 g solid anhydrous copper(II) sulfate, CuSO_4 , labelled **P**. This can be made by **carefully** heating hydrated copper(II) sulfate, $\text{CuSO}_4 \cdot 5\text{H}_2\text{O}$, until it is white/grey but not brown or blue
- (ii) 1 g solid ammonium chloride, NH_4Cl , labelled **Q**
- (iii) 1 g solid sodium chloride, NaCl , labelled **R**. This must be in the form of fine crystals
- [H] (iv) 25 cm^3 0.4 mol dm^{-3} sodium hydroxide, NaOH , labelled **sodium hydroxide**
- (v) 5 cm^3 0.1 mol dm^{-3} barium chloride, BaCl_2 , labelled **barium chloride**
- [N] [H] (vi) 5 cm^3 0.05 mol dm^{-3} silver nitrate, AgNO_3 , labelled **silver nitrate**
- (vii) supply of distilled water
- (viii) 25 cm^3 measuring cylinder
- (ix) 1 small beaker, about 100 cm^3
- (x) a thermometer (range $0 - 100 \text{ }^\circ\text{C}$ with $1 \text{ }^\circ\text{C}$ divisions)
- (xi) 6 test-tubes (approx. $125 \text{ mm} \times 15 \text{ mm}$)
- (xii) red litmus paper
- (xiii) means of holding a test-tube
- (xiv) a stirring rod
- (xv) Bunsen burner and a means to light it
- (xvi) a permanent marker pen or other means of labelling test-tubes.

Centres may provide fewer test-tubes, the minimum being 4 test-tubes (approx. $125 \text{ mm} \times 15 \text{ mm}$). If this is the case, during the experiment, candidates will have to rinse test-tubes with distilled water which must be provided.

For Question 3

Each candidate will require

- (i) a steel spring. An expendable steel spring is suitable, for example a 55 mm long spring, of diameter 15 mm (e.g. Philip Harris B8G87194)
- (ii) a clamp, stand and boss
- (iii) a 30 cm or 50 cm rule, graduated in millimetres
- (iv) masses of 100 g, 200 g, 300 g, 400 g and 500 g. A 100 g mass hanger with four 100 g slotted masses is ideal. If these are not available, a suitable light hook must be provided so that the masses can be hung on the spring
- (v) a stone of mass between 180 g and 220 g. The stone must be able to be fully immersed in the beaker or container in part (vi).
- (vi) a 500 cm³ beaker containing approximately 300 cm³ of cold water. The 500 cm³ beaker could be plastic or substituted for by a plastic or china mug of similar size.

Note:

1. The apparatus is to be set up for candidates as shown in Fig. 3.1. The spring is to be sufficiently high above the bench so that when the 500 g mass is hung on the spring, the bottom of the mass is approximately 10 cm above the surface of the bench.

Ensure that the spring is held tightly in the clamp.

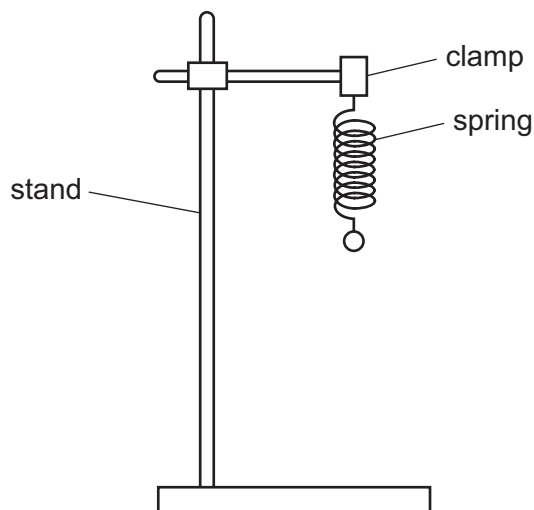

Fig. 3.1

2. There must be a means of allowing the stone to be hung from the spring. A small length of copper wire wound around the stone, with the end of the wire bent to form a hook shape is sufficient.
3. At changeover, ensure that the stone is removed from the spring and dried. Restore the apparatus to the form described in Note 1.

Spare materials and equipment should be available and can be provided without penalty. **Candidates should be made aware of this.**

Information required from the Supervisor:

The Supervisor is asked to carry out the experiments and to enter the results on a spare copy of the examination paper, clearly marked 'Supervisor's Results' and showing the Centre number. This should be done, out of sight of the candidates, using the same solutions, reagents, specimens and apparatus as the candidates.

A copy of the 'Supervisor's Results' should be returned with each packet of scripts. Failure to do so may cause the candidates to be penalised.

BLANK PAGE

This form must be completed and returned in the envelope with the scripts together with the seating plan and the Supervisor's Results as mentioned on page 6.

October/November 2014

General

The Supervisor is invited to give details of any difficulties experienced by particular candidates giving their names and candidate numbers. These should include reference to:

- (a) difficulties due to faulty apparatus;
- (b) accidents to apparatus or materials;
- (c) physical handicaps, e.g. short sight, colour blindness;
- (d) any other information that is likely to assist the Examiner, especially if this cannot be discovered in the scripts;
- (e) any help given to a candidate.

The Supervisor is asked to supply the following information:

Plan of work benches, giving details by candidate numbers of the places occupied by the candidates for each session and a copy of the 'Supervisor's Results'.

NAME OF CENTRE

SIGNED
Supervisor

CENTRE NUMBER

DECLARATION (to be signed by the Principal)

The preparation of this practical examination has been carried out so as to maintain fully the security of the examination.

NAME
(in block capitals)

SIGNED (Principal)



Permission to reproduce items where third-party owned material protected by copyright is included has been sought and cleared where possible. Every reasonable effort has been made by the publisher (UCLES) to trace copyright holders, but if any items requiring clearance have unwittingly been included, the publisher will be pleased to make amends at the earliest possible opportunity.

Cambridge International Examinations is part of the Cambridge Assessment Group. Cambridge Assessment is the brand name of University of Cambridge Local Examinations Syndicate (UCLES), which is itself a department of the University of Cambridge.