



Cambridge International Examinations
Cambridge International General Certificate of Secondary Education

CO-ORDINATED SCIENCES

0654/12

Paper 1 Multiple Choice

May/June 2015

45 minutes

Additional Materials: Multiple Choice Answer Sheet
Soft clean eraser
Soft pencil (type B or HB is recommended)

* 1 6 7 1 3 5 9 3 9 5 *

READ THESE INSTRUCTIONS FIRST

Write in soft pencil.

Do not use staples, paper clips, glue or correction fluid.

Write your name, Centre number and candidate number on the Answer Sheet in the spaces provided unless this has been done for you.

DO NOT WRITE IN ANY BARCODES.

There are **forty** questions on this paper. Answer **all** questions. For each question there are four possible answers **A, B, C** and **D**.

Choose the **one** you consider correct and record your choice in **soft pencil** on the separate Answer Sheet.

Read the instructions on the Answer Sheet very carefully.

Each correct answer will score one mark. A mark will not be deducted for a wrong answer.

Any rough working should be done in this booklet.

A copy of the Periodic Table is printed on page 20.

Electronic calculators may be used.

This document consists of **18** printed pages and **2** blank pages.

1 The diagram shows a palisade cell from a leaf.

Which labelled structure is a membrane?

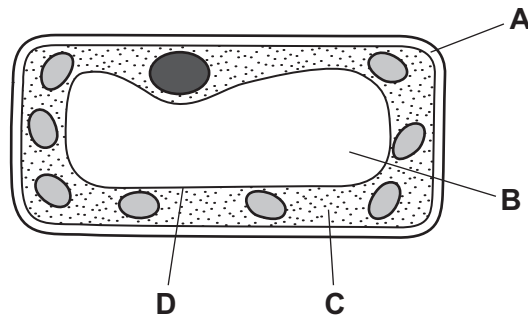

2 Which of these types of substances contains molecules that do **not** diffuse?

- A gases
- B solids
- C solutes
- D solvents

3 Which graph shows the effect of temperature on the rate of enzyme activity for a human enzyme?

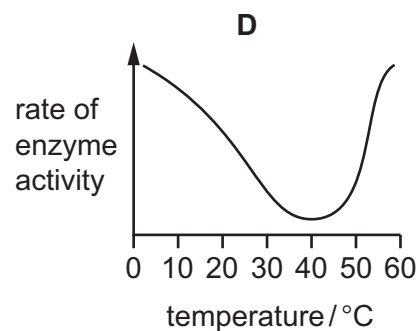
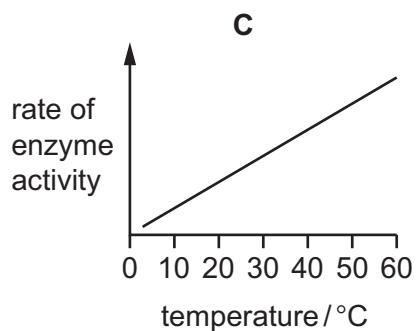
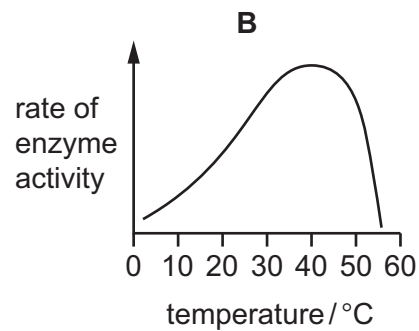
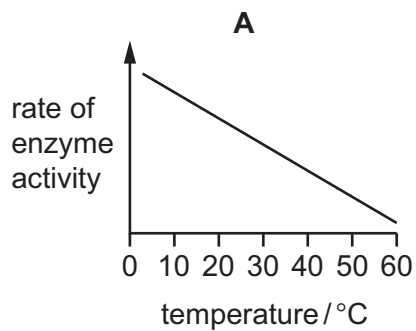

- 4 In a balanced diet, which constituents provide most energy?
- A carbohydrate and protein
 - B fat and carbohydrate
 - C fat and fibre
 - D vitamins and protein
- 5 The arrow shows urea leaving a cell and passing into structure P.

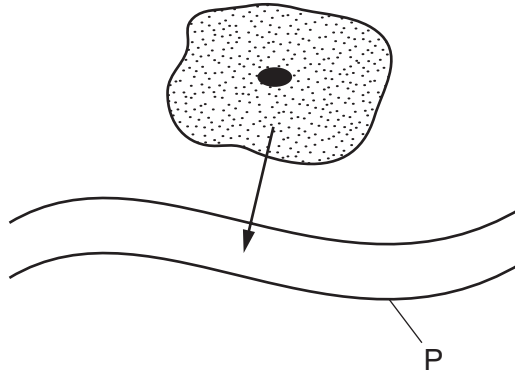

What is P?

- A a capillary
- B an artery
- C a vein
- D the small intestine

- 6 The diagram shows samples of blood from two different people as seen under a microscope.

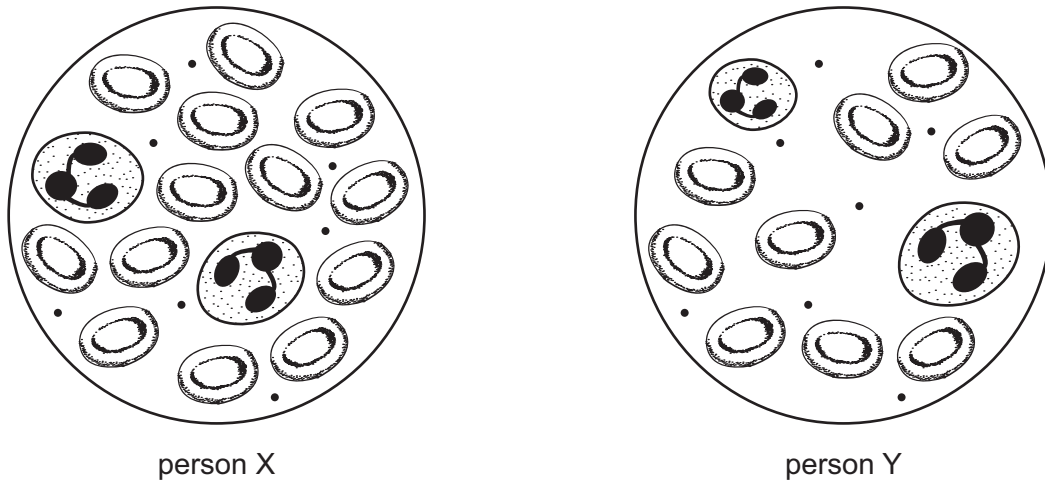

Compared with the blood of person Y, the blood of person X can

- A carry out more phagocytosis.
 - B clot more easily.
 - C produce more antibodies.
 - D transport more oxygen.
- 7 Which process in living organisms does **not** use energy from respiration?
- A growth
 - B movement
 - C photosynthesis
 - D temperature maintenance
- 8 A person touches a hot object which triggers a reflex action.
- In which order does the signal travel in the reflex arc?
- A relay neurone → spinal cord → sensory neurone
 - B sensory neurone → spinal cord → motor neurone
 - C spinal cord → sensory neurone → stimulus
 - D stimulus → motor neurone → spinal cord

- 9 Which statement about reproduction is correct?
- A Asexual reproduction involves the formation of haploid zygotes.
 - B Asexual reproduction produces offspring from two parents.
 - C Sexual reproduction involves the formation of diploid gametes.
 - D Sexual reproduction produces offspring that are genetically dissimilar.

- 10 The diagram shows the female reproductive system.

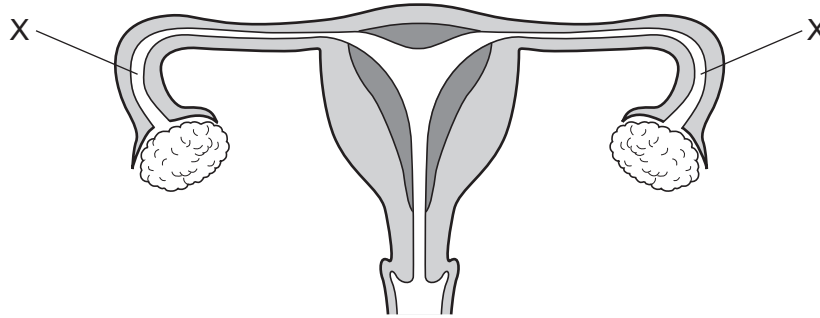

Sometimes the tubes at X can become blocked.

What is the result of this?

- A Eggs cannot reach the uterus.
 - B Menstruation is prevented.
 - C Ovulation is prevented.
 - D Sperms cannot reach the uterus.
- 11 Which process is responsible for the flow of energy along a food chain?
- A excretion
 - B feeding
 - C respiration
 - D seed dispersal

12 What can directly result from deforestation?

	build-up of atmospheric methane	flooding	loss of species
A	✓	✓	✗
B	✓	✗	✗
C	✗	✓	✓
D	✗	✗	✓

13 In the carbon cycle, which process removes carbon dioxide from the atmosphere?

- A** combustion
- B** decomposition
- C** photosynthesis
- D** respiration

14 The colours in an ink can be separated by chromatography.

Which diagram shows the correct way to set up the apparatus?

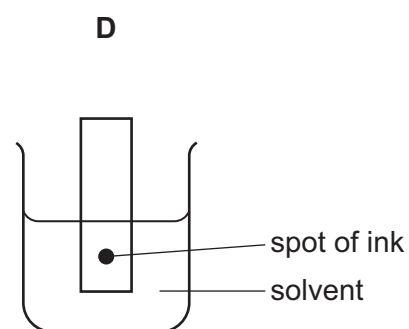
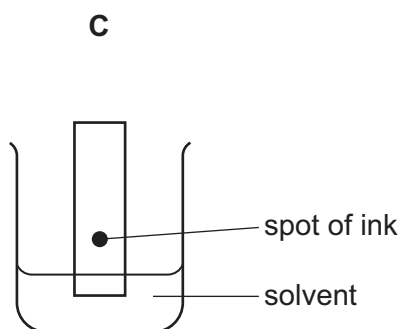
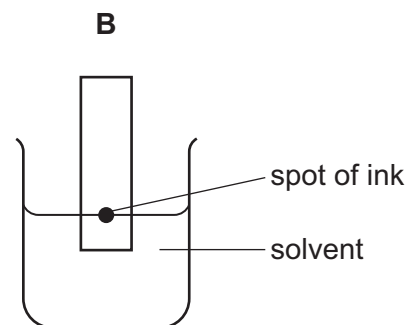
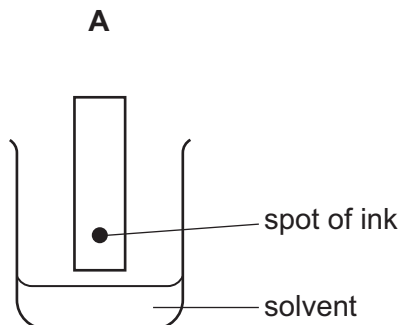

15 The positions of four elements are shown on the outline of part of the Periodic Table.

Which element forms an ion with a charge of 2+?

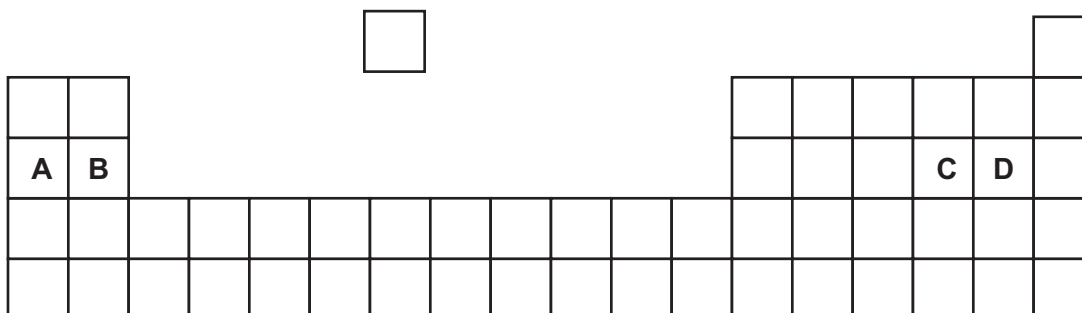

16 When dilute sulfuric acid is electrolysed using inert electrodes two gases are produced.

Which two gases are formed?

- A hydrogen and hydrogen sulfide
- B hydrogen and oxygen
- C hydrogen and sulfur dioxide
- D oxygen and sulfur dioxide

17 When sodium hydroxide and hydrochloric acid are mixed they react immediately.

The graph shows how the temperature of the mixture changes over time.

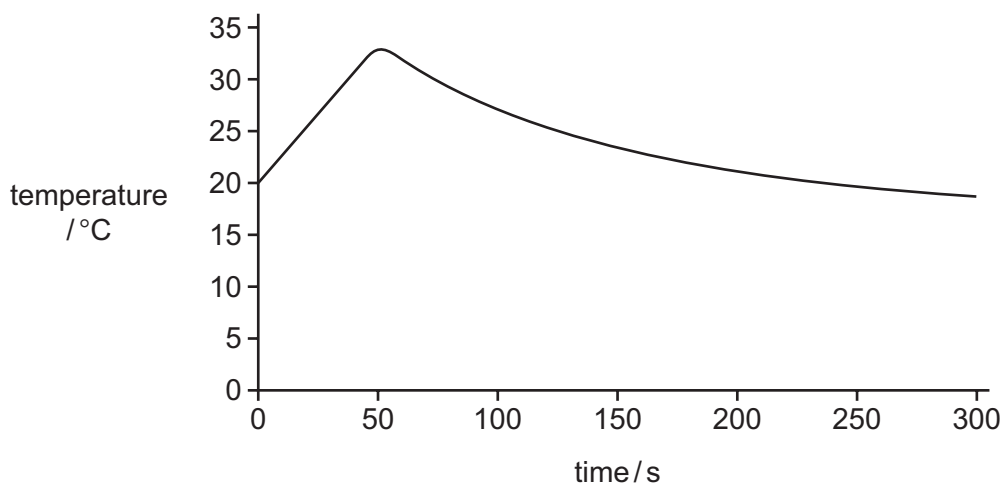

Which type of chemical reaction takes place?

- A both endothermic and exothermic
- B endothermic
- C exothermic
- D neither endothermic nor exothermic

- 18 Pure iron can be extracted from iron oxide using carbon monoxide.

The equation for the reaction is



Which row shows what happens to the iron oxide and carbon monoxide?

	iron oxide	carbon monoxide
A	oxidised	oxidised
B	oxidised	reduced
C	reduced	oxidised
D	reduced	reduced

- 19 Hydrogen and oxygen react explosively to form water.

Which words describe this reaction?

	combustion	oxidation
A	✓	✓
B	✓	x
C	x	✓
D	x	x

key

✓ = yes

x = no

- 20 Which processes are used to obtain crystals of sodium chloride from a mixture of sodium chloride and sand in water?

	first stage	second stage
A	crystallise	neutralise
B	evaporate	filter
C	filter	dissolve
D	filter	evaporate

- 21 What is observed when aqueous barium ions are added to sulfuric acid?

- A** blue precipitate
- B** brown gas
- C** colourless gas
- D** white precipitate

22 Elements X, Y and Z are the first three members of a group in the Periodic Table.

The elements are soft.

The elements react vigorously with water to produce hydrogen.

In which group of the Periodic Table are X, Y and Z found?

- A Group 0
- B Group I
- C Group II
- D Group VII

23 The table shows information about some minerals.

mineral	chemical formula
bauxite	Al_2O_3
galena	PbS
hematite	Fe_2O_3
rutile	TiO_2

Which minerals contain a transition element?

- A bauxite and galena
- B bauxite and hematite
- C galena and rutile
- D hematite and rutile

24 Air is a mixture of gases.

The diagram shows the composition of air.

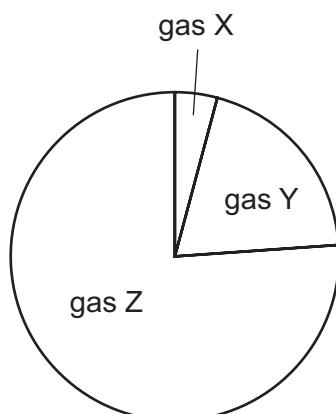

What are gases X, Y and Z?

	gas X	gas Y	gas Z
A	N ₂	O ₂	noble gases, CO ₂ , H ₂ O
B	noble gases, CO ₂ , H ₂ O	N ₂	O ₂
C	noble gases, CO ₂ , H ₂ O	O ₂	N ₂
D	O ₂	noble gases, CO ₂ , H ₂ O	N ₂

25 When limestone is heated, the following reaction takes place.

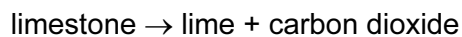

What are the chemical names of limestone and lime and which type of reaction does the limestone undergo?

	limestone	lime	type of reaction
A	calcium carbonate	calcium oxide	reduction
B	calcium carbonate	calcium oxide	thermal decomposition
C	calcium oxide	calcium carbonate	reduction
D	calcium oxide	calcium carbonate	thermal decomposition

26 The hydrocarbon dodecane has the formula $C_{12}H_{26}$.

Dodecane forms ethene and some ethane when it is heated.

What is the name of the process?

- A cracking
- B distillation
- C evaporation
- D fractional distillation

27 A fuel used for cooking food is the hydrocarbon ...1... that burns in an ...2... reaction.

Which words correctly complete gaps 1 and 2?

	1	2
A	coke	endothermic
B	coke	exothermic
C	methane	endothermic
D	methane	exothermic

28 The circuit of a motor racing track is 3.0 km in length. In a race, a car goes 25 times round the circuit in 30 minutes.

What is the average speed of the car?

- A 75 km/hour
- B 90 km/hour
- C 150 km/hour
- D 750 km/hour

29 The diagrams show four solid blocks with the same mass.

Which block is made from the **least** dense material?

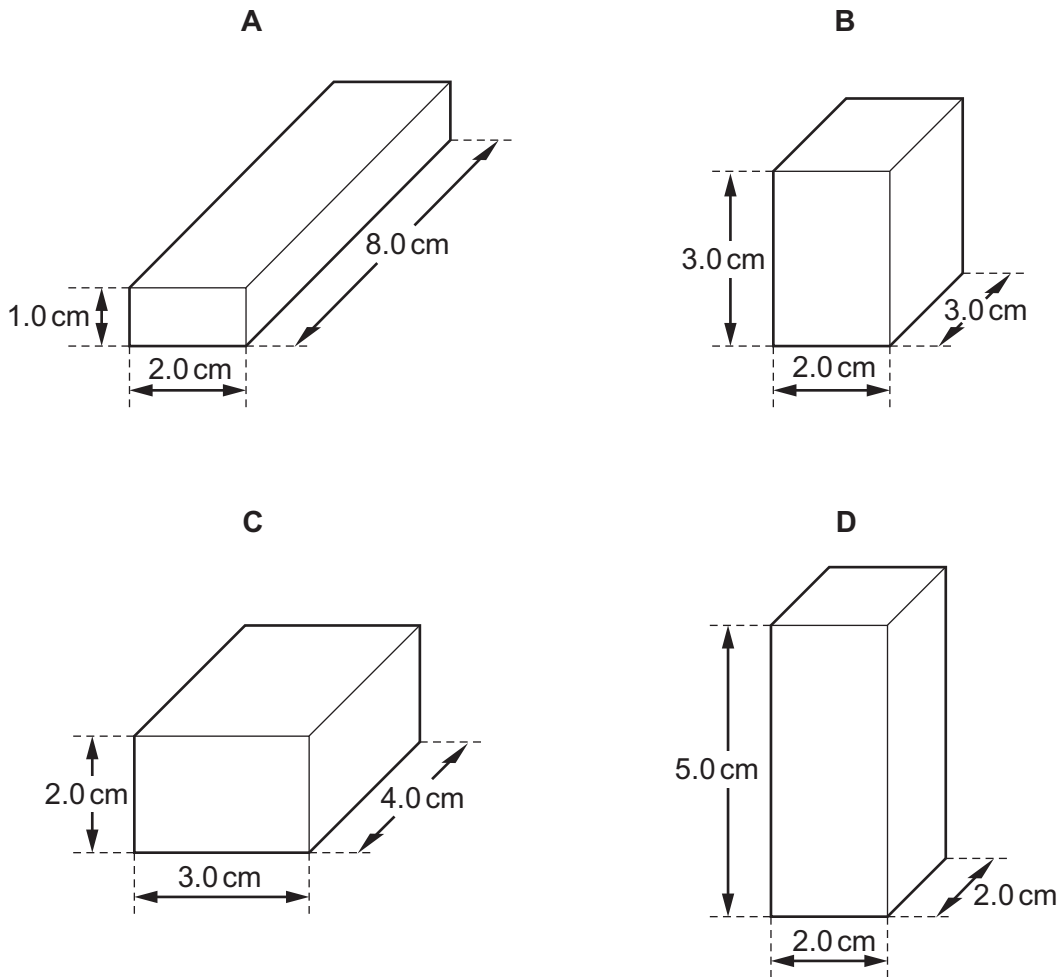

30 A train travels along a horizontal track at constant speed. Two of the forces acting on the train are shown in the diagram.

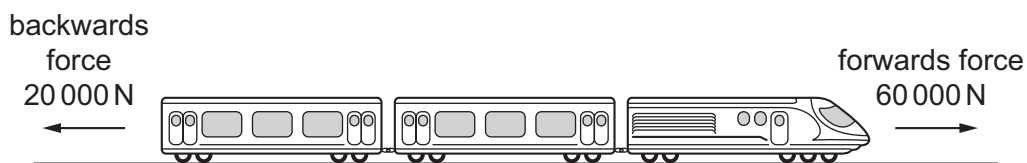

A force of air resistance is also acting on the train to give it a resultant force of zero.

What is this air resistance force?

- A 40 000 N backwards
- B 80 000 N backwards
- C 40 000 N forwards
- D 80 000 N forwards

- 31 What is the source of the energy converted by a hydro-electric power station?
- A chemical energy of oil
 - B gravitational energy of falling water
 - C kinetic energy of waves
 - D thermal energy of hot rocks
- 32 Which is the best description of the molecules in a solid at 0°C?
- A close together and moving from one position to another and changing places with other molecules
 - B close together and vibrating about a fixed position
 - C far apart and moving from one position to another and changing places with other molecules
 - D far apart and not moving at all
- 33 There is a vacuum between the double walls of a vacuum flask.
- Which types of heat transfer are reduced by the vacuum?
- A conduction, convection and radiation
 - B conduction and convection only
 - C conduction and radiation only
 - D convection and radiation only

34 The diagrams show examples of wave motion.

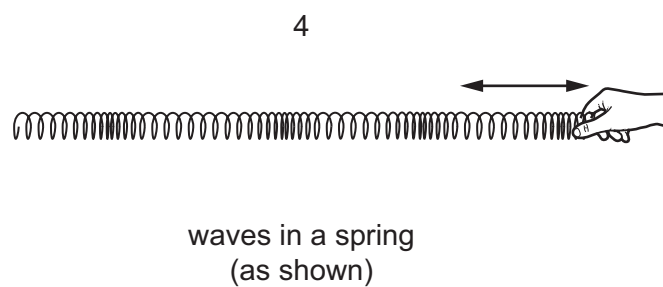
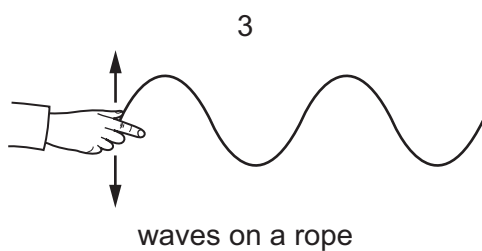
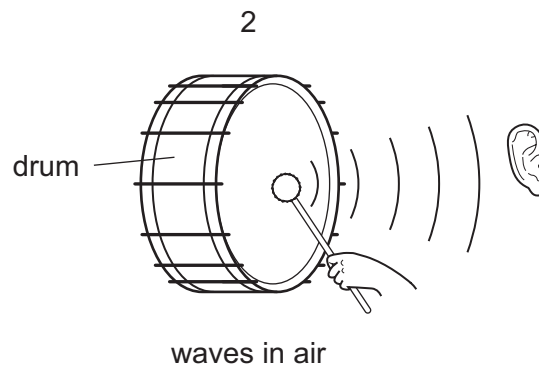
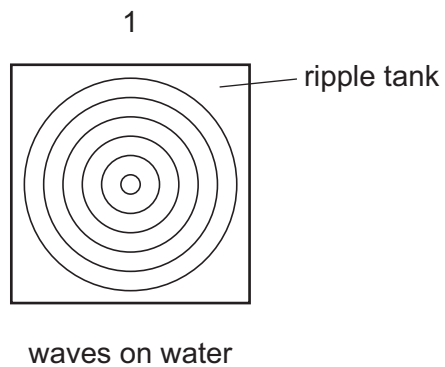

Which waves are longitudinal?

- A 1 only
- B 2 and 3 only
- C 2, 3 and 4 only
- D 2 and 4 only

35 The diagram shows two rays of light passing through a converging lens.

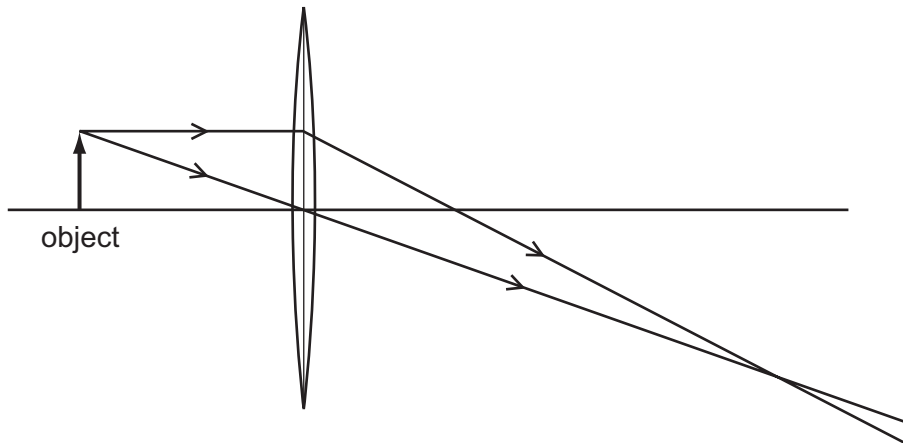

Which type of image is formed?

- A inverted and larger than the object
 - B inverted and smaller than the object
 - C upright (erect) and larger than the object
 - D upright (erect) and smaller than the object
- 36 An explosion experiment is carried out on Earth. The experiment is repeated by an astronaut in space where there is no gas or air.

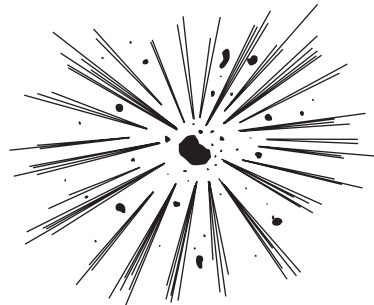
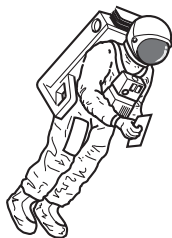

How does the explosion sound to the astronaut in space?

- A slightly louder than on Earth
- B the same loudness as on Earth
- C slightly quieter than on Earth
- D completely silent

37 A student makes a permanent magnet using a piece of metal and a magnetising coil.

Which metal should she use?

- A aluminium
- B copper
- C iron
- D steel

38 What is the symbol for a fuse?

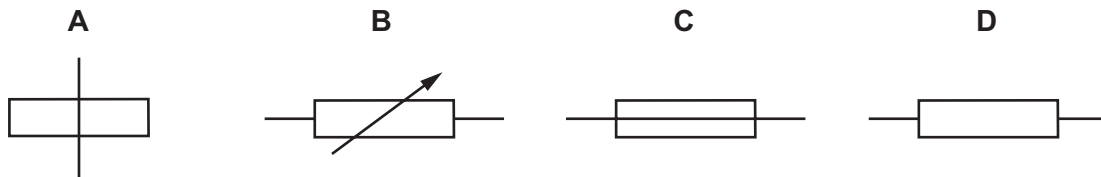

39 The diagram shows a battery connected to two resistors. Three ammeters M_1 , M_2 and M_3 are connected in the circuit.

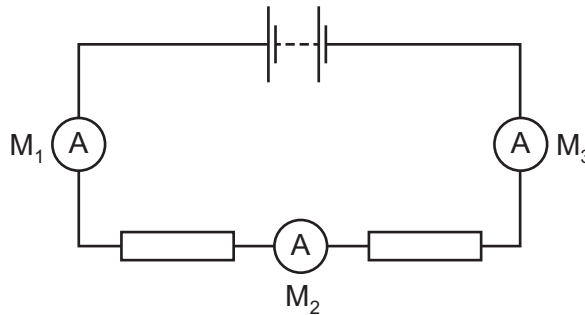

Meter M_1 reads 1.0 A.

What are the readings on M_2 and on M_3 ?

	reading on M_2 / A	reading on M_3 / A
A	0.5	0.0
B	0.5	0.5
C	0.5	1.0
D	1.0	1.0

40 Which type of radiation has the greatest ionising effect?

- A infra-red rays
- B α -particles
- C β -particles
- D γ -rays

BLANK PAGE

BLANK PAGE

DATA SHEET
The Periodic Table of the Elements

		Group																											
I	II	III	IV	V	VI	VII	0																						
		1 H Hydrogen 1						4 He Helium 2																					
7 Li Lithium 3	9 Be Beryllium 4						11 B Boron 5	12 C Carbon 6	14 N Nitrogen 7	16 O Oxygen 8	19 F Fluorine 9	20 Ne Neon 10																	
23 Na Sodium 11	24 Mg Magnesium 12						27 Al Aluminium 13	28 Si Silicon 14	31 P Phosphorus 15	32 S Sulfur 16	35.5 Cl Chlorine 17	40 Ar Argon 18																	
39 K Potassium 19	40 Ca Calcium 20						70 Ga Gallium 31	73 Ge Germanium 32	75 As Arsenic 33	79 Se Selenium 34	80 Br Bromine 35	84 Kr Krypton 36																	
85 Rb Rubidium 37	88 Sr Strontium 38						64 Cu Copper 29	65 Zn Zinc 30	106 Pd Palladium 46	108 Ag Silver 47	112 Cd Cadmium 48	115 In Indium 49	119 Sn Tin 50	122 Sb Antimony 51	127 I Iodine 53	131 Xe Xenon 54													
133 Cs Caesium 55	137 Ba Barium 56						59 Co Cobalt 27	56 Fe Iron 26	103 Rh Rhodium 45	106 Pd Palladium 46	197 Au Gold 79	201 Hg Mercury 80	204 Tl Thallium 81	207 Pb Lead 82	209 Bi Bismuth 83	210 Po Polonium 84	210 At Astatine 85	210 Rn Radon 86											
226 Ra Radium 88	227 Ac Actinium 89						55 Mn Manganese 25	59 Ni Nickel 28	101 Ru Ruthenium 44	106 Pd Palladium 46	195 Pt Platinum 78	201 Hg Mercury 80	204 Tl Thallium 81	207 Pb Lead 82	209 Bi Bismuth 83	210 Po Polonium 84	210 At Astatine 85	210 Rn Radon 86											
													140 Ce Cerium 58	141 Pr Praseodymium 59	144 Nd Neodymium 60	150 Sm Samarium 62	152 Eu Europium 63	157 Gd Gadolinium 64	162 Dy Dysprosium 66	165 Ho Holmium 67	167 Er Erbium 68	169 Tm Thulium 69	173 Yb Ytterbium 70	175 Lu Lutetium 71					
													232 Th Thorium 90	238 U Uranium 92	238 U Uranium 92	94 Pu Plutonium 94	95 Am Americium 95	96 Cm Curium 96	98 Cf Californium 98	99 Es Einsteinium 99	100 Fm Fermium 100	101 Md Mendelevium 101	102 No Nobelium 102	103 Lr Lawrencium 103					

*58-71 Lanthanoid series
†90-103 Actinoid series

a	X	†
Key	X	†
	b	†

a = relative atomic mass
X = atomic symbol
b = proton (atomic) number

The volume of one mole of any gas is 24 dm³ at room temperature and pressure (r.t.p.).