



Cambridge International Examinations
Cambridge International General Certificate of Secondary Education

CANDIDATE
NAME

CENTRE
NUMBER

--	--	--	--	--	--

CANDIDATE
NUMBER

--	--	--	--	--

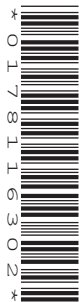

CO-ORDINATED SCIENCES

0654/32

Paper 3 (Extended)

May/June 2016

2 hours

Candidates answer on the Question Paper.

No Additional Materials are required.

READ THESE INSTRUCTIONS FIRST

Write your Centre number, candidate number and name on all the work you hand in.

Write in dark blue or black pen.

You may use an HB pencil for any diagrams or graphs.

Do not use staples, paper clips, glue or correction fluid.

DO NOT WRITE IN ANY BARCODES.

Answer **all** questions.

Electronic calculators may be used.

You may lose marks if you do not show your working or if you do not use appropriate units.

A copy of the Periodic Table is printed on page 32.

At the end of the examination, fasten all your work securely together.

The number of marks is given in brackets [] at the end of each question or part question.

This document consists of **31** printed pages and **1** blank page.

1 A student adds four liquids to four solids.

Fig. 1.1 shows the four experiments **A**, **B**, **C** and **D**.

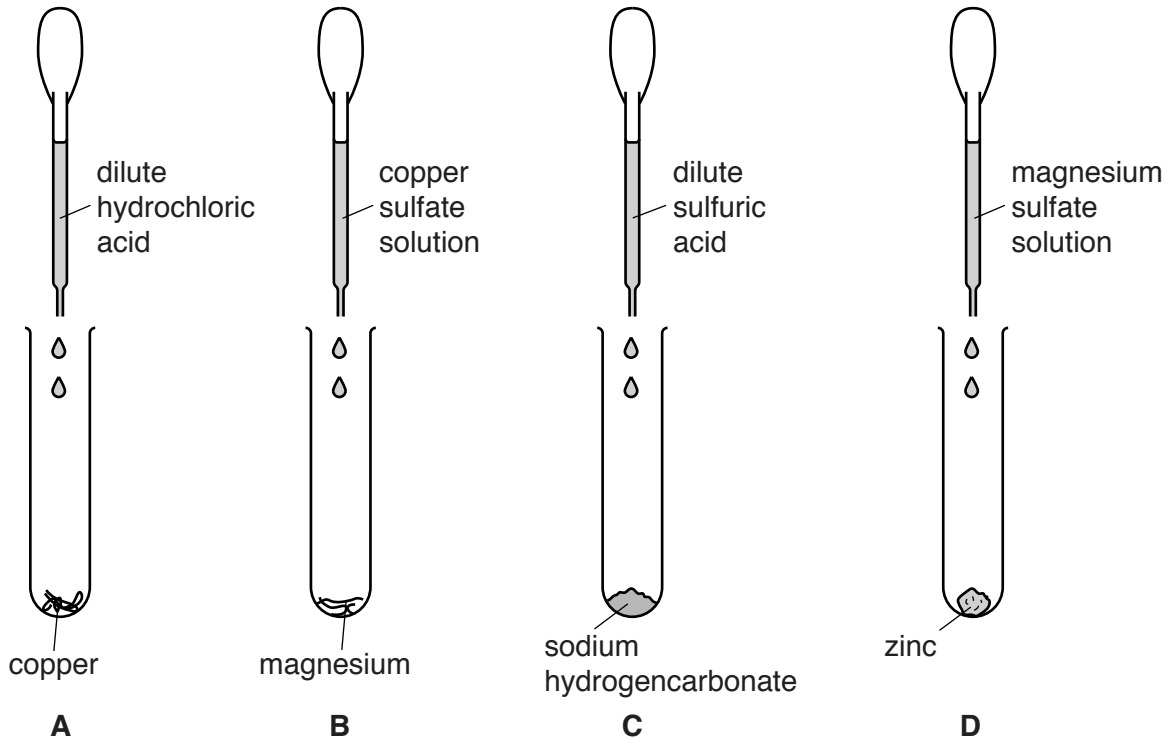

Fig. 1.1

(a) (i) Give the letter of the experiment in which a reaction occurs that releases a gaseous compound.

Name the gaseous compound.

experiment

name of gaseous compound [2]

(ii) Give the letter of the experiment which involves a change of colour.

Explain your answer.

experiment

explanation

.....

..... [2]

(b) Table 1.1 shows the temperature measurements the student makes during his investigation.

Table 1.1

experiment	temperature of substances before mixing/ $^{\circ}\text{C}$	temperature of the mixture after one minute/ $^{\circ}\text{C}$
A	22	22
B	22	45
C	22	15
D	22	22

(i) Give the letter of the experiment in which an exothermic reaction occurs.

Explain your answer.

reaction

explanation

.....

[1]

(ii) Give the letter of the experiment in which there is a decrease in the speed of the molecules.

Explain your answer in terms of the energy conversion that occurs.

reaction

explanation

.....

.....

[2]

(iii) Explain the results for experiment **A**.

.....

.....

..... [2]

2 (a) Plants lose water by evaporation.

(i) State the term for the loss of water from a plant by evaporation.

.....[1]

(ii) Describe and explain how the rate of this evaporation is affected by the number of stomata in a leaf.

.....

[1]

(iii) Most leaves have more stomata on their underside than on their upper surface.

Suggest why this is an advantage for the plant.

.....
[2]

(b) Fig. 2.1 shows the rate of water loss and the rate of water uptake for a plant over a period of one day.

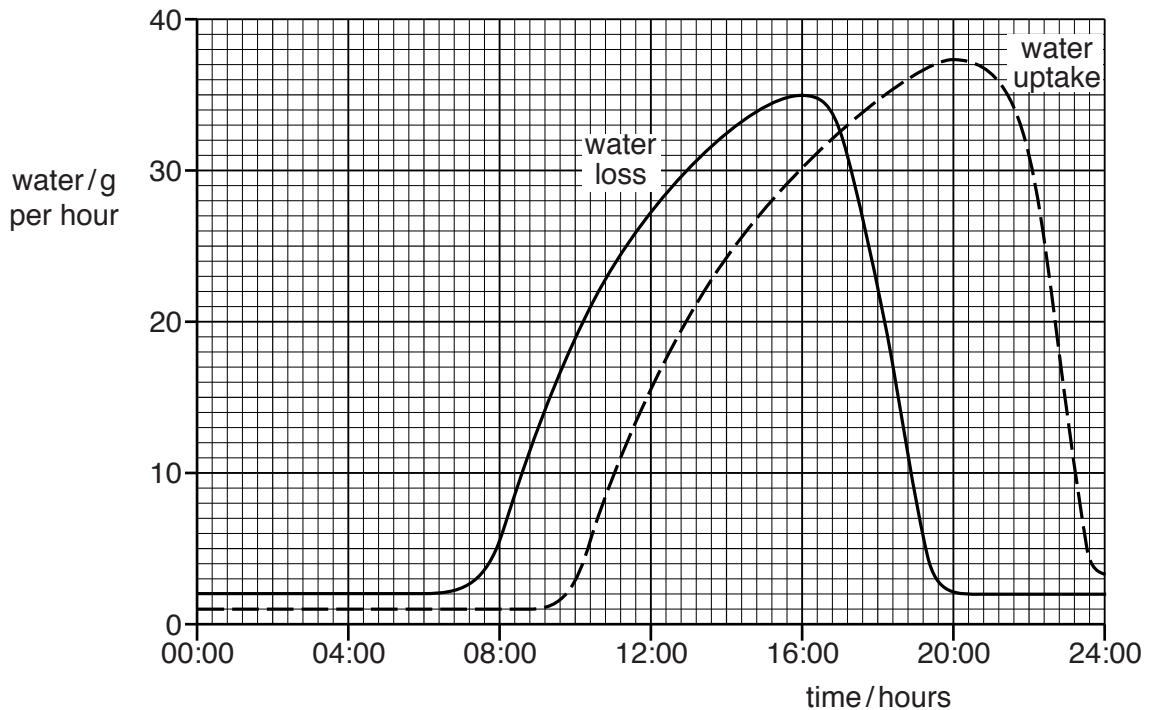

Fig. 2.1

(i) For this day, state

the time at which the rate of water loss is greatest,

.....

a time when the rate of water loss is the same as the rate of water uptake.

.....

[2]

(ii) Describe the relationship between water loss and water uptake that is shown in Fig. 2.1.

.....

.....

..... [2]

(c) State **two** ways in which the structure of a root hair helps a plant to absorb water.

1

2

[2]

- 3 Fig. 3.1 shows an aircraft of mass $3.6 \times 10^5 \text{ kg}$ moving with constant acceleration from rest along an airport runway.

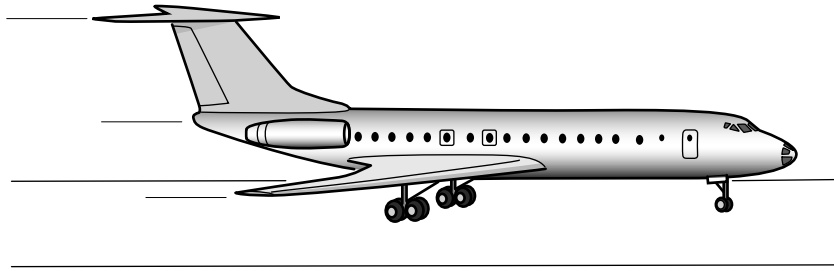

Fig. 3.1

- (a) After 30 seconds the aircraft reaches a speed of 60 m/s .
- (i) Calculate the kinetic energy of the aircraft, when travelling at 60 m/s .

State the formula you use and show your working.

formula

working

kinetic energy = J [2]

- (ii) Calculate the acceleration of the aircraft during the first 30 seconds.

Show your working.

acceleration = m/s^2 [2]

- (b) Just after taking off, the aircraft continues to accelerate as it gains height.

State **two** forms of energy gained by the aircraft during this time.

1

2

[1]

- (c) State the difference between the terms *speed* and *velocity*.

.....

.....[1]

- (d) The aircraft has 20 tyres. Each tyre has an area of 0.06 m^2 in contact with the ground when the aircraft is on the runway.

The weight of the aircraft is 3 600 000 N.

Calculate the pressure exerted by the aircraft on the runway.

State the formula you use and show your working.

formula

working

pressure = N/m^2 [3]

- (e) It has been raining and there is a large puddle of water on the runway.

State **two** factors that would increase the rate at which the water evaporates from the puddle.

1

2

[2]

(f) Fig. 3.2 shows an aircraft being refuelled through a rubber pipe.

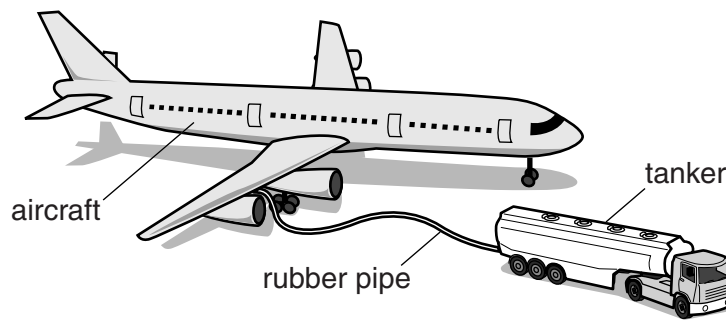

Fig. 3.2

As the fuel flows through the rubber pipe, it becomes positively charged.

Suggest, in terms of electrons, why the fuel becomes positively charged.

.....

.....

.....[2]

- 4 Fig. 4.1 shows a hot-air balloon with a propane gas burner and a helium-filled airship.

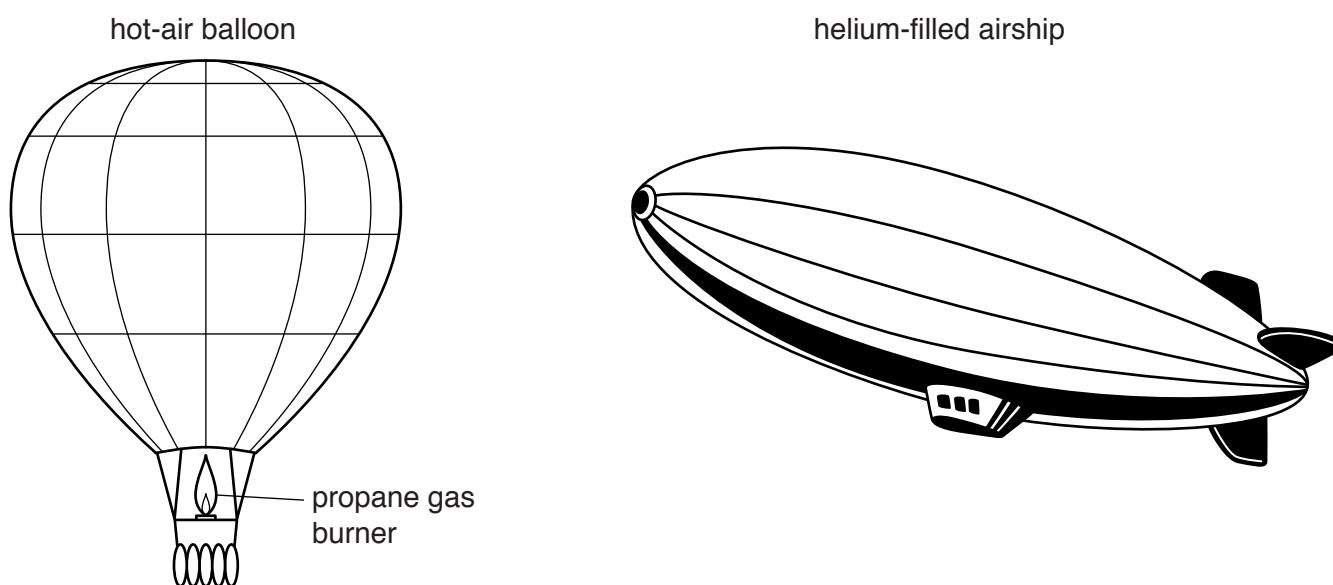

Fig. 4.1

- (a) Both helium and hydrogen could be used to fill airships.

Explain why helium is preferred to hydrogen for filling airships designed to transport people.

.....

.....

..... [2]

- (b) Propane is an alkane. A molecule of propane contains three carbon atoms.

Complete the diagram to show one molecule of propane.

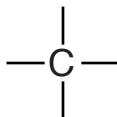

[2]

(c) Explain, in terms of the properties of molecules, why propane has a higher boiling point than helium.

.....

.....

.....

..... [2]

- 5 (a) Fig. 5.1 shows part of a food web from a rainforest. The food web is a network of interconnecting food chains.

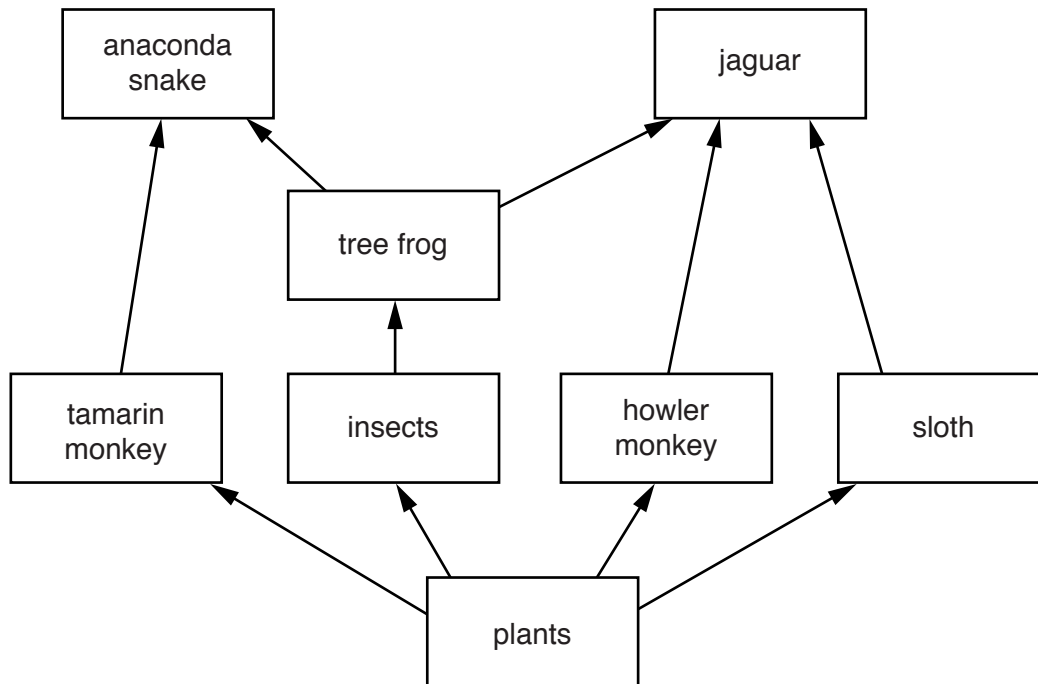

Fig. 5.1

- (i) State the number of trophic levels in the longest food chain in Fig. 5.1.
[1]
- (ii) Name an organism in Fig. 5.1 that is at the second trophic level.
[1]
- (iii) Explain why food webs rarely have more than five trophic levels.

[2]
- (iv) Name a **type** of organism that might feed on **all** of the organisms shown in Fig. 5.1.
[1]

(b) In the last 50 years, large areas of rainforest have been cut down for timber. Some of the timber has been used as building material and some has been used as fuel.

(i) Many people believe that cutting down trees increases the amount of carbon dioxide in the Earth's atmosphere.

Explain why cutting down trees could cause this increase.

.....
.....
.....
.....[2]

(ii) Explain why using timber as a fuel will have more effect on the Earth's atmosphere than using timber as a building material.

.....
.....[1]

- 6 (a) Fig. 6.1 shows an incomplete diagram of the electromagnetic spectrum.

radio waves				ultraviolet		gamma radiation
-------------	--	--	--	-------------	--	-----------------

Fig. 6.1

Visible light is part of the electromagnetic spectrum.

On Fig. 6.1 write **visible light** in the correct position. [1]

- (b) Gamma radiation is emitted from some unstable nuclei. Gamma radiation is ionising.

- (i) State **one** risk to humans of exposure to ionising radiation.

.....
 [1]

- (ii) Alpha radiation is also emitted from some unstable nuclei.

State **one** difference between gamma radiation and alpha radiation.

.....
 [1]

(c) Visible light is able to pass through an optical fibre by total internal reflection.

Fig. 6.2 shows a student's diagram of total internal reflection along the optical fibre. The diagram contains some errors.

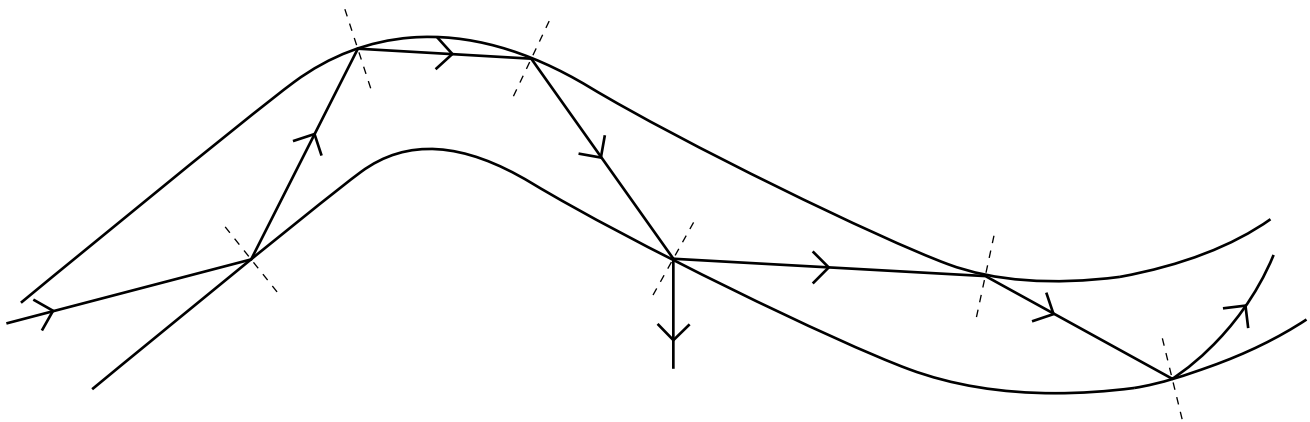

Fig. 6.2

On Fig. 6.2, circle **two** errors the student has made in their diagram.

Describe the errors you have identified.

error 1

.....

.....

error 2

.....

.....

[3]

(d) The frequency of red light is 4×10^{14} Hz. Red light travels at a speed of 3×10^8 m/s in a vacuum.

(i) Calculate the wavelength of red light.

State the formula you use and show your working.

formula

working

wavelength = m [2]

(ii) The frequency of blue light is 6.5×10^{14} Hz. Write down the speed of blue light in a vacuum.

Explain your answer.

speed = m/s

explanation

.....
[1]

7 (a) Homeostasis depends on negative feedback. Explain what is meant by the term *negative feedback*.

.....

 [2]

(b) Fig. 7.1 shows part of the alimentary canal and some associated organs.

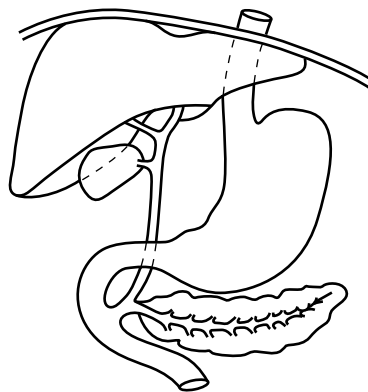

Fig. 7.1

(i) On Fig. 7.1, label the pancreas. [1]

(ii) The pancreas helps to maintain a constant concentration of glucose in the blood.

Use the words in the list to complete the sentences about the pancreas.

Each word may be used once, more than once, or not at all.

- | | | | |
|-------------------|----------------|-----------------|-----------------|
| adrenaline | amylase | glucagon | glycogen |
| insulin | kidneys | liver | starch |

When the blood glucose concentration is too high, the pancreas secretes
 into the blood. This causes the
 to convert glucose to If the blood glucose is too low,
 the pancreas secretes

[4]

8 Fig. 8.1 shows two cars. One car is painted black. The other car is painted white.

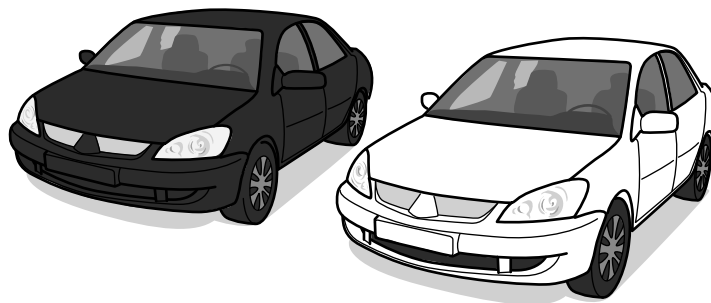

Fig. 8.1

(a) The cars are left outside on a hot, sunny day.

(i) State the method of energy transfer by which energy travels from the Sun to the Earth.

.....[1]

(ii) State the process by which energy is released in the Sun.

.....[1]

(iii) The black car gets much hotter than the white car.

Suggest why the black car gets hotter than the white car.

.....
.....[1]

(b) Each of the cars has its own electrical generator to generate electricity for the car.

Fig. 8.2 shows a simple a.c. generator.

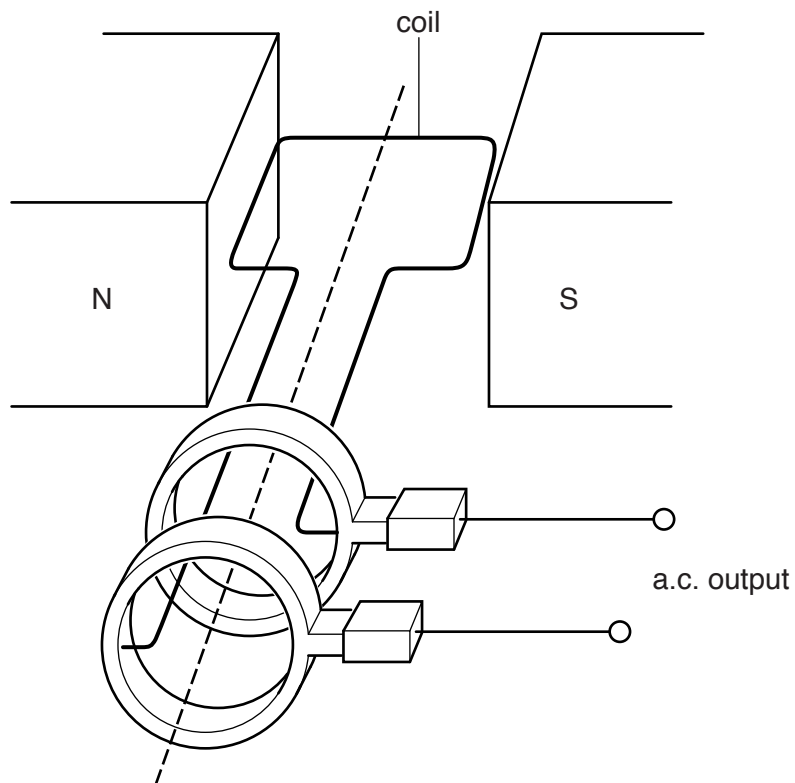

Fig. 8.2

Explain how the rotation of the coil in the magnetic field and the use of slip rings produce an alternating current.

.....

.....

.....

.....

.....

.....

.....

.....

[3]

(c) The engine in a car is noisy. It emits a sound with a frequency of 5000 Hz.

(i) State what is meant by the term *frequency*.

.....
.....[1]

(ii) While he was driving, the driver notices that the noise from the engine becomes quieter and the frequency of the sound waves decreases.

State whether the sound waves have

a larger or smaller amplitude than the original sound waves,

.....

a higher or lower pitch than the original sound waves.

.....

[1]

(iii) The sound waves produced travel through the air by compressions and rarefactions.

Describe the difference between a compression and a rarefaction.

.....
.....[1]

- 9 (a) (i) Use data from the Periodic Table on page 32 to describe how the electrons are arranged in an atom of sodium.

You may draw a diagram if it helps your answer.

.....
.....[2]

- (ii) Rubidium, Rb, is an element in the same group of the Periodic Table as sodium, Na.

State how the arrangements of the electrons in these two elements cause them to have very similar chemical properties.

.....
.....[1]

- (b) Sodium is obtained by electrolysis of molten sodium chloride, NaCl.

Describe, in terms of the particles involved, what happens at the cathode during this electrolysis.

.....
.....
.....[2]

- (c) Fig. 9.1 shows the apparatus and materials used to investigate the reaction between sodium and water.

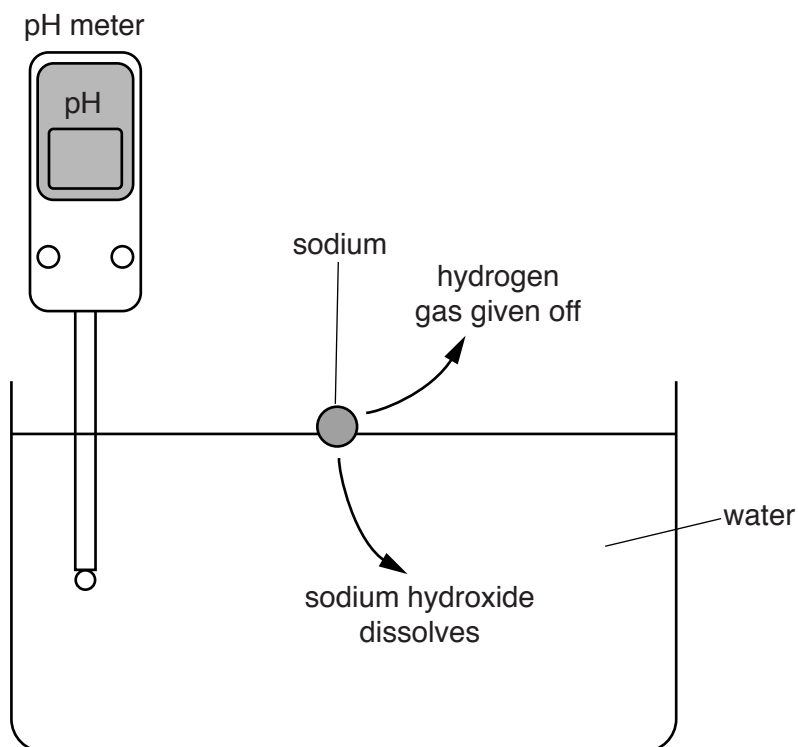

Fig. 9.1

The reaction between sodium and water produces hydrogen gas and a solution of sodium hydroxide, NaOH.

- (i) Suggest and explain the reading of the pH meter at the end of the reaction.

pH reading

explanation

.....

[2]

- (ii) Write the balanced symbol equation for the reaction between sodium and water.

.....[2]

- (d) Lithium hydroxide is used in space vehicles to remove the carbon dioxide produced by the astronauts.

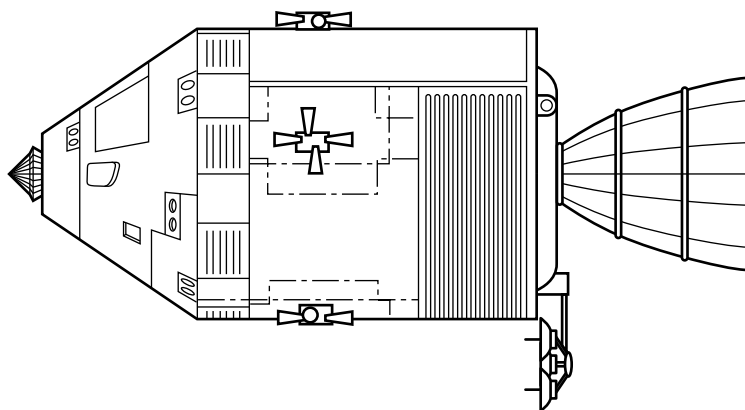

The balanced equation for this reaction is shown.

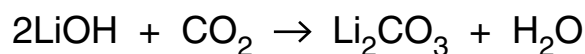

It is estimated that during a particular mission, the astronauts will produce a total of 1000 moles of carbon dioxide.

Calculate the minimum mass of lithium hydroxide needed to react with 1000 moles of carbon dioxide.

Show your working and state the unit of your answer.

Relative atomic masses may be found in the Periodic Table on page 32.

mass = unit = [3]

10 Cystic fibrosis (CF) is a genetic disorder that can be caused by a mutation.

(a) State what is meant by the term *mutation*.

.....

.....

.....[2]

(b) Fig. 10.1 shows the inheritance of cystic fibrosis in a family.

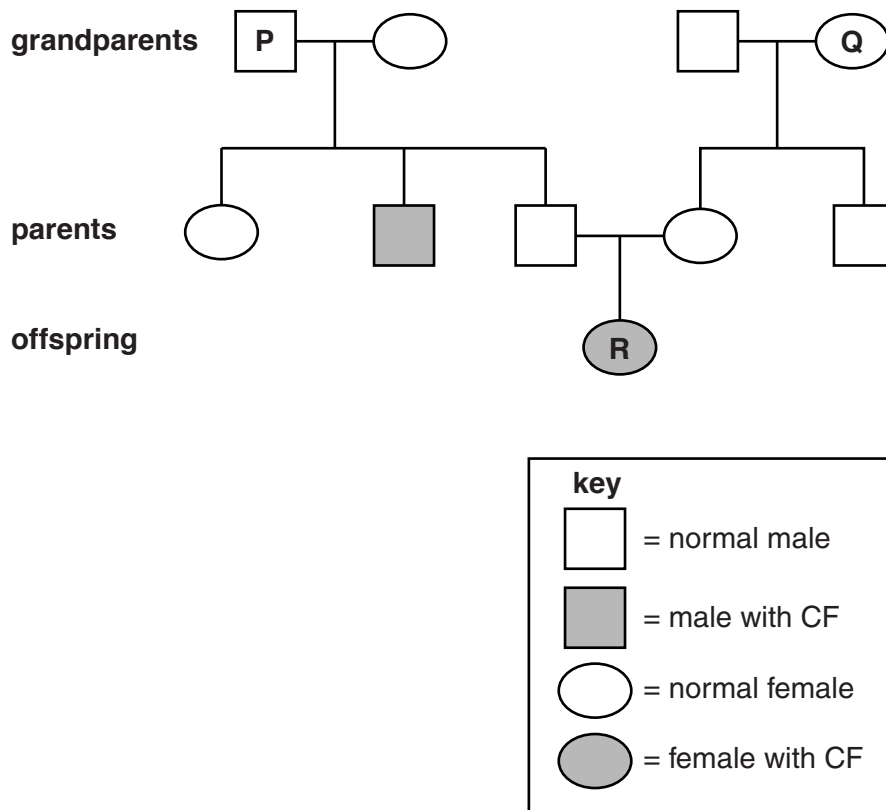

Fig. 10.1

(i) Using the symbols **N** (allele for normal) and **n** (allele for CF), state all the possible genotypes of the people labelled **P** and **Q**.

P

Q

[3]

(ii) With reference to Fig. 10.1, explain why this family tree shows that the allele for cystic fibrosis must be recessive.

.....

.....

.....[2]

11 Sulfur is a yellow crystalline solid that occurs naturally in the Earth's crust.

(a) Fig. 11.1 shows a diagram of a molecule of sulfur.

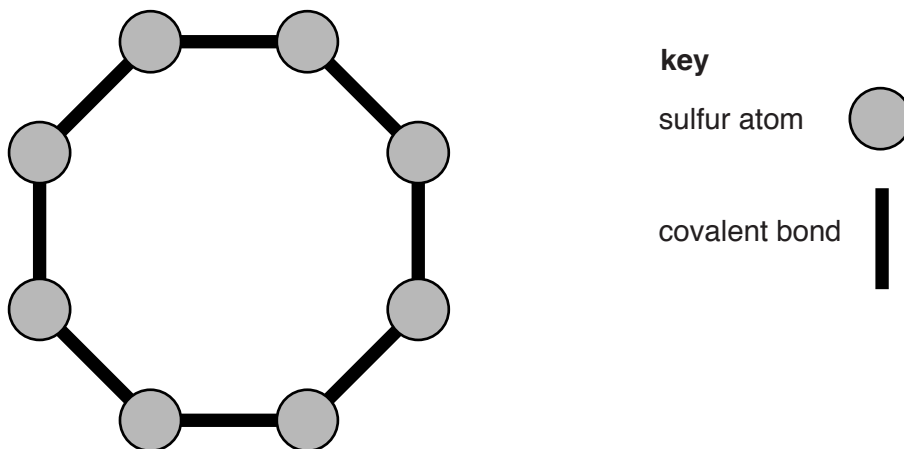

Fig. 11.1

(i) State the chemical formula of the molecule shown in Fig. 11.1.

.....[1]

(ii) Explain why Fig. 11.1 shows that sulfur is an element and not a compound.

.....
.....[1]

- (b) Fig. 11.2 shows the apparatus and materials used by a teacher to demonstrate the formation of sulfur dioxide by burning sulfur in air.

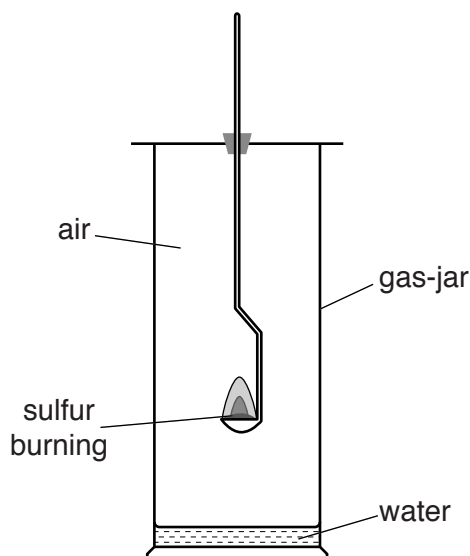

Fig. 11.2

- (i) Some of the sulfur dioxide dissolves and reacts with the water in the bottom of the gas-jar to form an aqueous solution.

Predict and explain the colour of full-range indicator (Universal Indicator) when added to this aqueous solution.

colour

explanation

[2]

- (ii) State the percentages of nitrogen and oxygen in unpolluted air.

oxygen %

nitrogen %

[1]

- (iii) The teacher repeats the demonstration using pure oxygen instead of air.

Predict how the rate of burning will change when using pure oxygen instead of air.

.....[1]

- (iv) Explain your answer to (b)(iii) in terms of collisions between reactant molecules.

.....

.....

.....[2]

- (c) Sulfur is an industrial raw material used in the Contact process. It is burned in air to make sulfur dioxide.

Fig. 11.3 is a diagram of part of the Contact process.

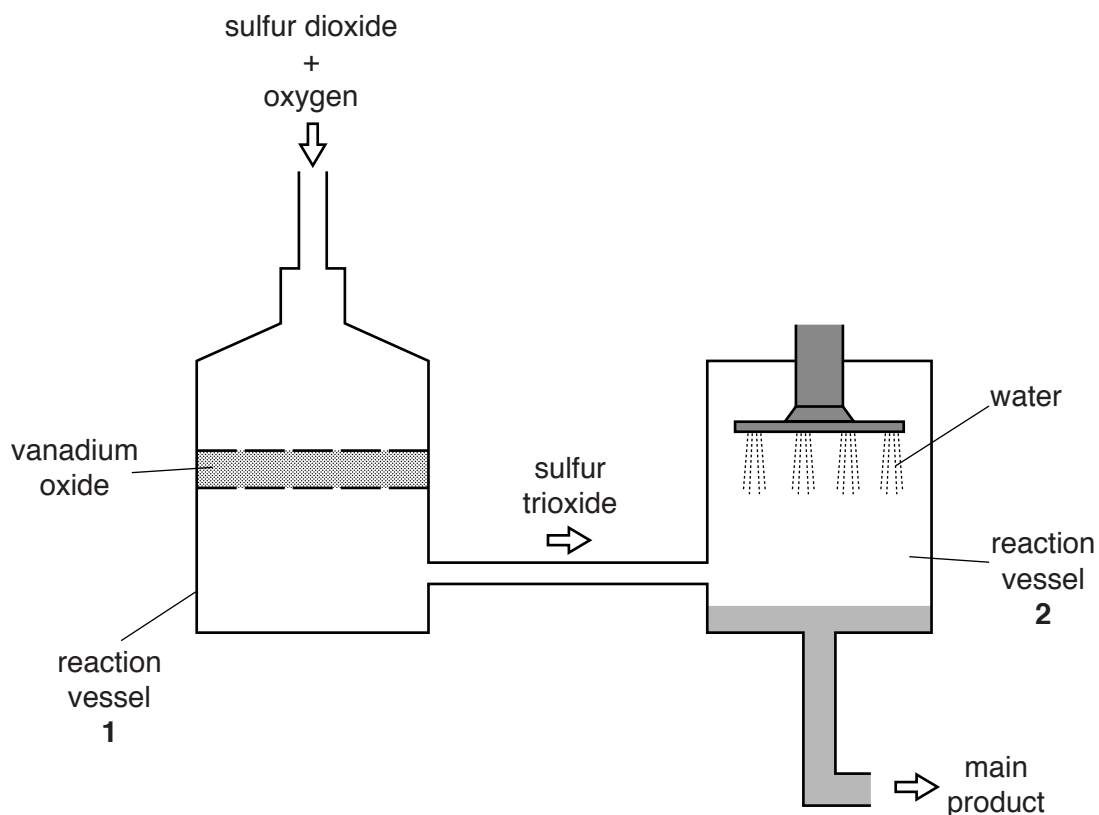

Fig. 11.3

- (i) The word equation for the reaction in vessel 1 is shown.



Explain why the word equation does **not** include vanadium oxide.

.....
[2]

- (ii) Name the main product leaving vessel 2.

.....[1]

(d) Sulfur can react with hydrogen to form hydrogen sulfide, H_2S .

Fig. 11.4 shows a student's attempt to draw a dot and cross diagram of all the outer electrons in a molecule of hydrogen sulfide.

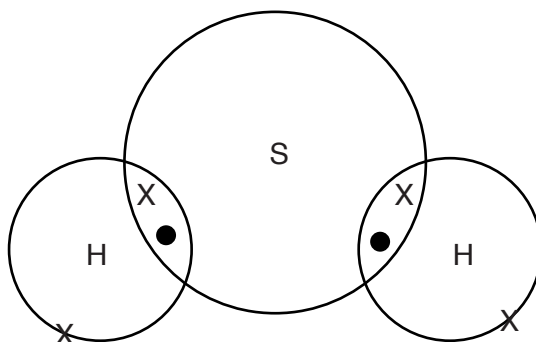

Fig. 11.4

The student's diagram is incorrect.

Redraw the diagram correctly in the space below.

[2]

12 (a) A torch contains four cells, a filament lamp and a switch connected in series.

Draw a circuit diagram for the torch using the correct electrical circuit symbols.

[3]

(b) The current in the lamp is 0.7 A when it is at normal brightness.

The torch is switched on for 20 minutes.

Calculate the total charge that passes through the lamp in this time.

State the formula you use and show your working. State the unit of your answer.

formula

working

charge = unit = [3]

30

- (c) Two lamps, one of resistance $4\ \Omega$ and one of resistance $12\ \Omega$, are connected in parallel.

Calculate the total resistance of these two lamps in parallel.

State the formula you use and show your working.

formula

working

resistance = Ω [2]

- (d) A resistor of $3\ \Omega$ and a resistor of $10\ \Omega$ can be arranged either in series or in parallel and then connected to a battery.

Use ticks (\checkmark) to show which statements in Table 12.1 are correct.

Table 12.1

	in series	in parallel
the current in each resistor is the same		
the potential difference across each resistor is the same		

[1]

13 Fig. 13.1 shows a cross-section through a pond. The pond contains plants growing near the surface of the water. At the bottom of the pond there is mud which contains bacteria.

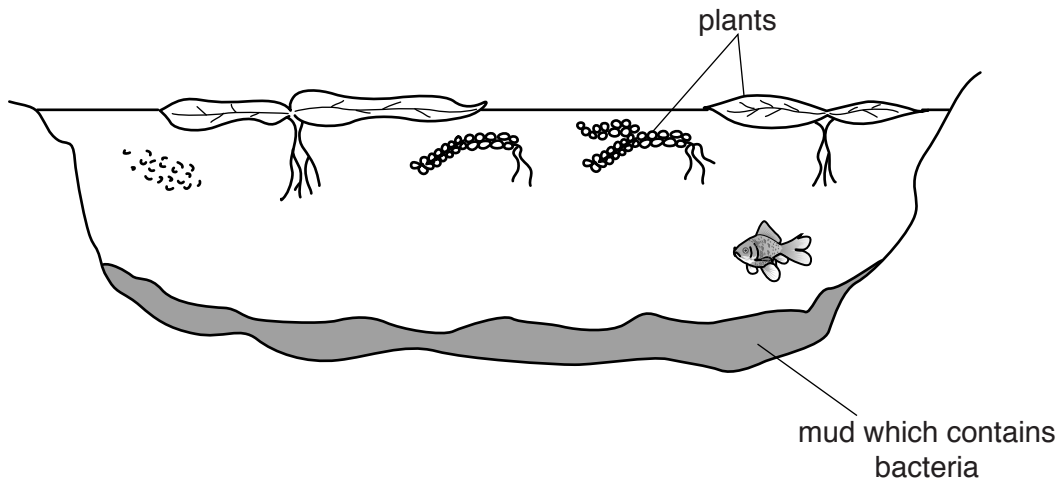

Fig. 13.1

(a) Explain the advantage for the plants of being at the top of the pond rather than at the bottom.

.....
 [2]

(b) A farmer accidentally spills some fertiliser into the pond.

Suggest and explain what effect this would have on

(i) the plants,

.....

 [2]

(ii) the bacteria,

.....

 [2]

(iii) the fish living in the pond.

.....

 [2]

