



Cambridge International Examinations
Cambridge International General Certificate of Secondary Education

CANDIDATE
NAME

CENTRE
NUMBER

--	--	--	--	--

CANDIDATE
NUMBER

--	--	--	--



CO-ORDINATED SCIENCES

0654/33

Paper 3 (Extended)

May/June 2016

2 hours

Candidates answer on the Question Paper.

No Additional Materials are required.

READ THESE INSTRUCTIONS FIRST

Write your Centre number, candidate number and name on all the work you hand in.

Write in dark blue or black pen.

You may use an HB soft pencil for any diagrams or graphs.

Do not use staples, paper clips, glue or correction fluid.

DO NOT WRITE IN ANY BARCODES.

Answer **all** questions.

Electronic calculators may be used.

You may lose marks if you do not show your working or if you do not use appropriate units.

A copy of the Periodic Table is printed on page 36.

At the end of the examination, fasten all your work securely together.

The number of marks is given in brackets [] at the end of each question or part question.

This document consists of **34** printed pages and **2** blank pages.

1 Aluminium foil is made when aluminium is rolled into thin sheets.

Aluminium foil is used to make food containers and fizzy-drink cans.

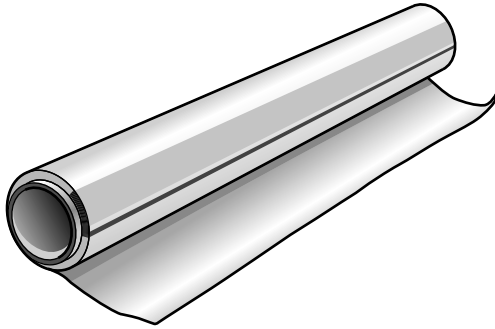

roll of aluminium foil

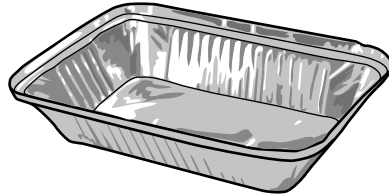

food container

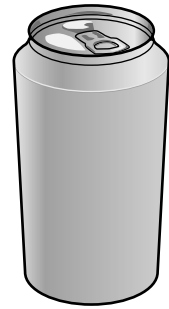

fizzy-drink can

(a) (i) State the property of aluminium that allows it to be rolled into thin sheets.

.....[1]

(ii) Many types of food and drink are acidic.

State the property of aluminium that makes it suitable for making food containers and fizzy-drink cans.

.....[1]

(b) Aluminium used to make fizzy-drink cans contains small amounts of other metals.

As well as the liquid, the fizzy-drink can contains gas under pressure.

(i) State the word used for a mixture of metals.

.....[1]

(ii) Suggest a reason why aluminium containing small amounts of other metals, rather than pure aluminium, is used for fizzy-drink cans.

.....
.....
.....[2]

- (c) Fig. 1.1 shows the industrial electrolysis that is used to extract aluminium from aluminium oxide.

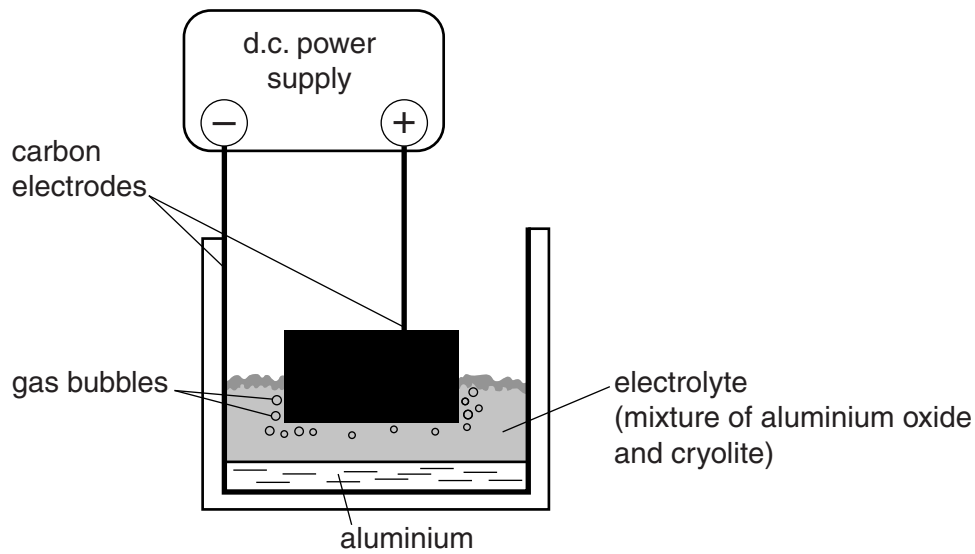

Fig. 1.1

- (i) Explain why the process shown in Fig. 1.1 only works when the electrolyte is strongly heated.

.....

 [2]

- (ii) State the number of electrons that each aluminium ion gains from the cathode during electrolysis.

Give a reason for your answer.

number of electrons

reason

 [2]

- (iii) Fig. 1.2 shows an unused carbon anode and how it looks after being used for several days.



Fig. 1.2

State the balanced chemical equation for a reaction that causes this loss of mass of the anode material during electrolysis.

.....[2]

2 (a) Fig. 2.1 shows some blood, as seen through a microscope.

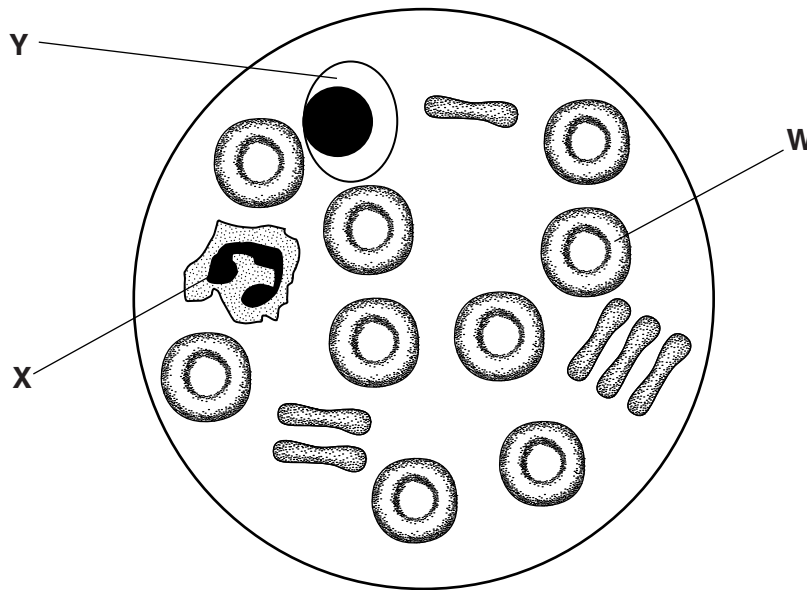

Fig. 2.1

(i) Name the part of the blood labelled W.

.....[1]

(ii) The cell labelled X carries out phagocytosis. Describe the process of phagocytosis.

.....
.....
.....[2]

(iii) Describe how the cell labelled Y would respond if a person received a blood transfusion of the wrong blood type, and describe the effect that this response would have.

response of the cells

.....
.....

effect of this response

.....
.....

[2]

(b) (i) State how the function of an artery differs from the function of a vein.

.....
.....[1]

(ii) Explain why it is important that arteries have thick walls.

.....
.....
.....[2]

(iii) Describe the function of the elastic tissue in the artery wall.

.....
.....
.....[2]

- 3 (a) Some oil leaks from an oil tanker. It forms a very thin layer of oil on the surface of the seawater.

The layer of oil covers a rectangular area measuring 2.5×10^3 m by 5.0×10^3 m.

The layer of oil is 3.0×10^{-6} m (0.000 003 m) thick.

- (i) Calculate the volume of the layer of oil leaked.

volume = m³ [1]

- (ii) The density of the oil is 880 kg/m³.

Calculate the mass of the oil that leaked from the oil tanker.

State the formula you use and show your working.

formula

working

mass = kg [2]

(b) The oil tanker is carrying crude oil. Crude oil is a non-renewable energy resource.

Other energy resources are shown in Table 3.1.

Table 3.1

	non-renewable	renewable
coal		
geothermal energy		
hydroelectricity		
natural gas		
solar		
energy from ocean waves		
tidal energy		

Identify **two** non-renewable energy resources by placing a tick (✓) in the non-renewable column.

Identify **two** renewable energy resources by placing a tick (✓) in the renewable column.

[1]

(c) The depth of the sea below the oil tanker is determined by sending out pulses of ultrasound waves through the water. The ultrasound pulses reflect off the sea bed and the echoes are detected on the oil tanker.

(i) Humans cannot hear ultrasound waves.

State the normal audible frequency range for a human.

from Hz to Hz

[1]

- (ii) The echo of an ultrasound wave emitted by the oil tanker is detected 1.2 seconds later. The speed of ultrasound waves in water is 1500 m/s.

Calculate the depth of the sea below the oil tanker.

State the formula you use and show your working.

formula

working

distance = m [2]

- (iii) When ultrasound waves pass through the water, they travel as a series of compressions (C) and rarefactions (R).

Fig. 3.1 shows the positions of the compressions and rarefactions as the ultrasound wave passes through the water.



Fig. 3.1

On Fig. 3.1, sketch a similar ultrasound wave with an increased wavelength. Show the compressions (C) and rarefactions (R).

Label **one** wavelength on your drawing using a double headed arrow (\longleftrightarrow). [1]

4 In the African savannah (grassland), zebras feed on grass. They are preyed on by carnivores, such as lions. The lions have fleas in their fur. The fleas feed on the lions' blood.

(a) Construct a food chain containing four organisms, based on this description.

[2]

(b) State the term that describes

(i) an area such as the savannah, with all the organisms in it and their environment, interacting together,

.....[1]

(ii) the position of an organism in a food chain,

.....[1]

(iii) an organism that gets its energy from dead or waste organic matter.

.....[1]

(c) State and explain which **one** of the four organisms described above has the most energy flowing through it.

.....
.....[2]

- 5 (a) Fig. 5.1 shows two headlamps in a car. The headlamps are connected in parallel with the battery. A switch and a fuse are also connected in the circuit.

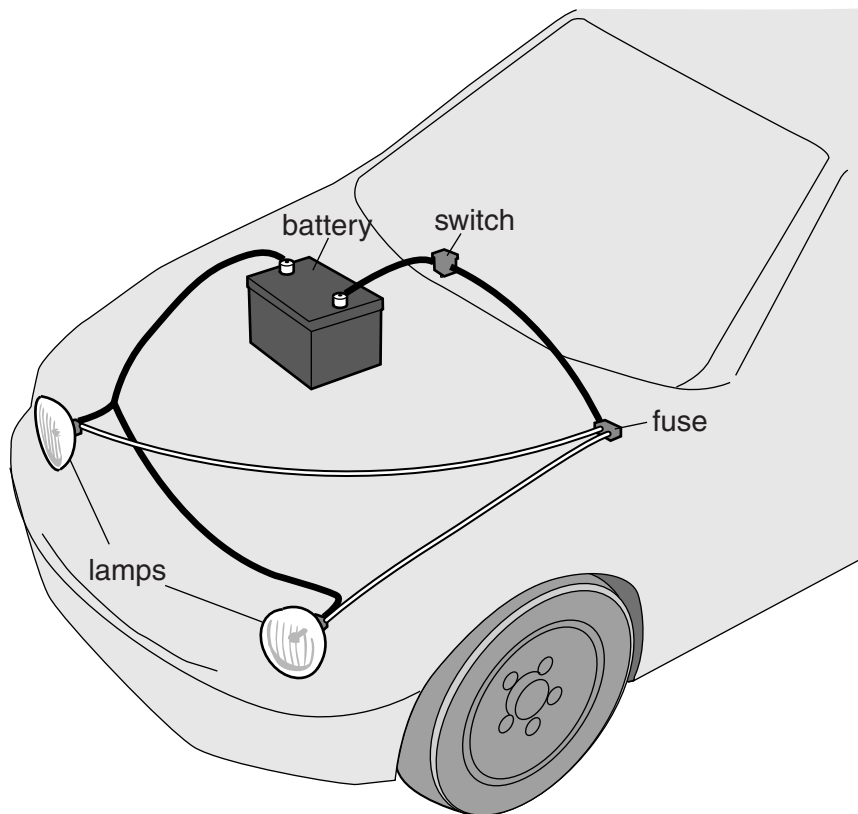

Fig. 5.1

- (i) Draw the circuit diagram for the car headlamps, shown in Fig. 5.1, using circuit symbols.

[2]

- (ii) The car battery provides an e.m.f. of 12V. When the headlamps are switched on, there is a current of 1.5A through **each** headlamp.

Calculate the charge that passes through one headlamp in 5 minutes.

State the formula you use and show your working. Give the unit of your answer.

formula

working

charge = unit = [3]

- (b) The headlamps of the car emit visible light of several different wavelengths. One of the wavelengths is 4.8×10^{-7} m.

- (i) The frequency of this light is 6.25×10^{14} Hz.

Calculate the speed of this light.

State the formula you use and show your working.

formula

working

speed = m/s [2]

- (ii) Visible light is part of the electromagnetic spectrum.

State **one** property that is the same for all electromagnetic waves.

.....[1]

(c) A small panel of the bodywork of the car is painted using an electrostatic paint spray gun.

The paint droplets leave the spray gun with a positive electric charge.

The bodywork panel is given a negative electric charge.

This is shown in Fig. 5.2.

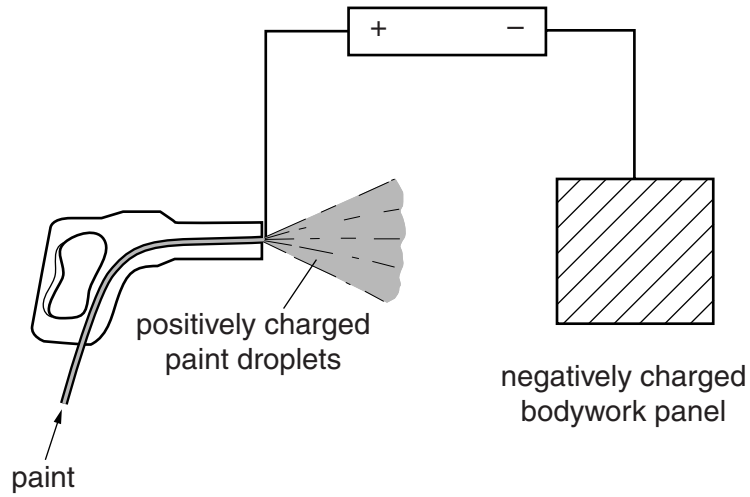

Fig. 5.2

Explain why this method spreads the paint evenly.

.....

.....

.....[2]

(d) The driver of a car sees a bus in his mirror, as shown on Fig. 5.3.



Fig. 5.3

Apart from any changes in size, describe **one** characteristic of the image that he sees.

.....[1]

(e) It has been raining and there is a large puddle of water on the road.

State **two** factors that would increase the rate at which the water evaporates from the puddle.

1

2

[2]

- 6 (a) Fig. 6.1 shows what happens when a sperm fertilises an egg, and how the cell produced by fertilisation then divides.

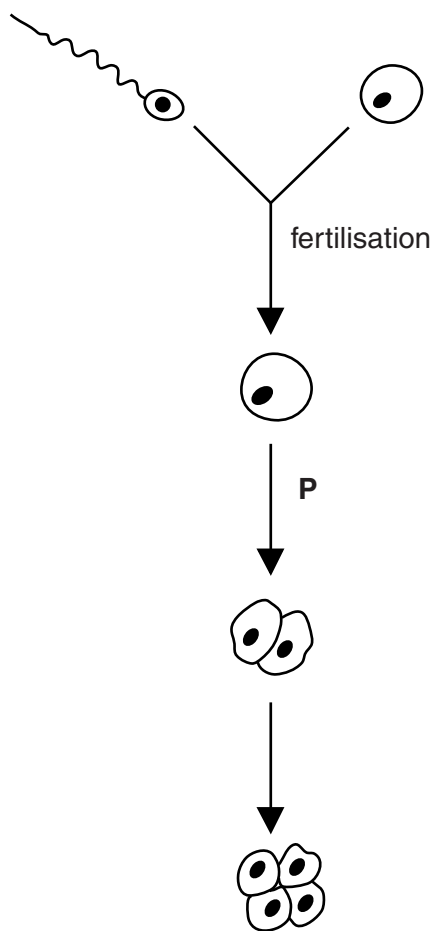

Fig. 6.1

- (i) On Fig. 6.1, label,
with the letter **D**, a cell that is diploid,
with the letter **H**, a cell that is haploid. [1]
- (ii) Name the type of cell division that is occurring at **P**.
.....[1]
- (iii) The sperm cell contains 23 chromosomes. State the number of chromosomes in
the egg cell before it is fertilised,
the fertilised egg. [2]

(b) Sexual reproduction increases variety within a species.

(i) Name another process that can produce completely new varieties within a species.

.....[1]

(ii) Explain how variety in a species could be important for the survival of the population if the climate where a population of plants is growing becomes much drier,

.....

.....

an antibiotic is used against a population of bacteria.

.....

.....

[2]

(c) Fig. 6.2 shows the frequency of different blood groups within a population of people.

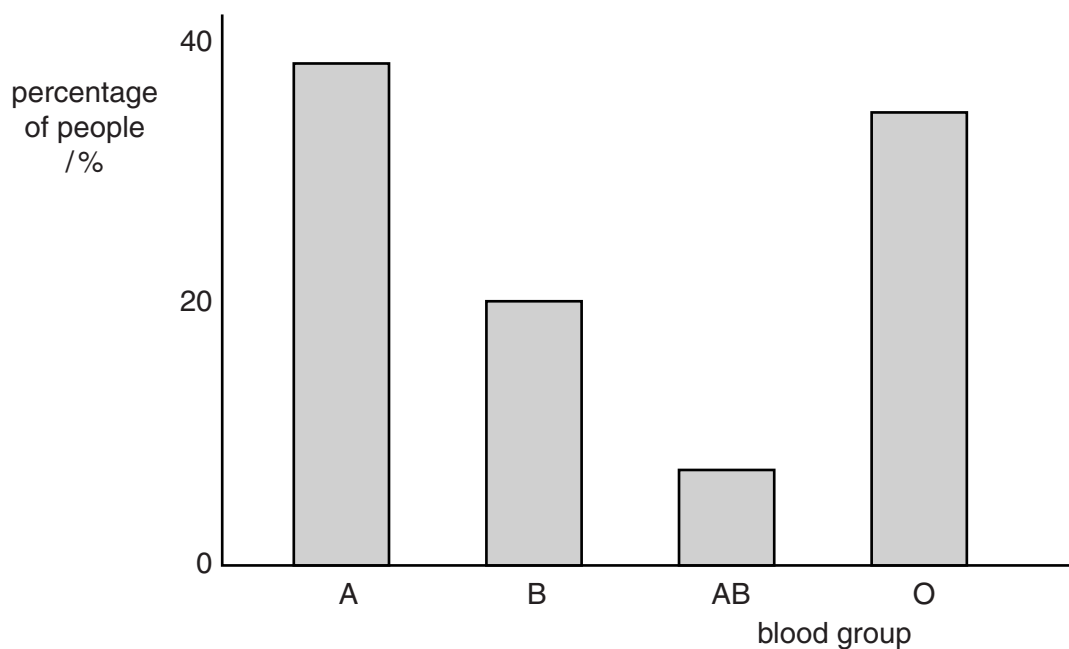

Fig. 6.2

(i) In Fig. 6.2, state which is the most common blood group.

.....[1]

(ii) Name the **type** of variation that is shown by blood groups in humans.

.....[1]

(iii) State what causes people to have different blood groups.

.....[1]

- 7 (a) A black powder, **Q**, is added to an aqueous solution of a compound **R** and a gas is released. The gas relights a glowing splint.

Name the gas released in this reaction.

.....[1]

- (b) Fig. 7.1 shows apparatus and materials a student uses to investigate the speed of the reaction described in (a).

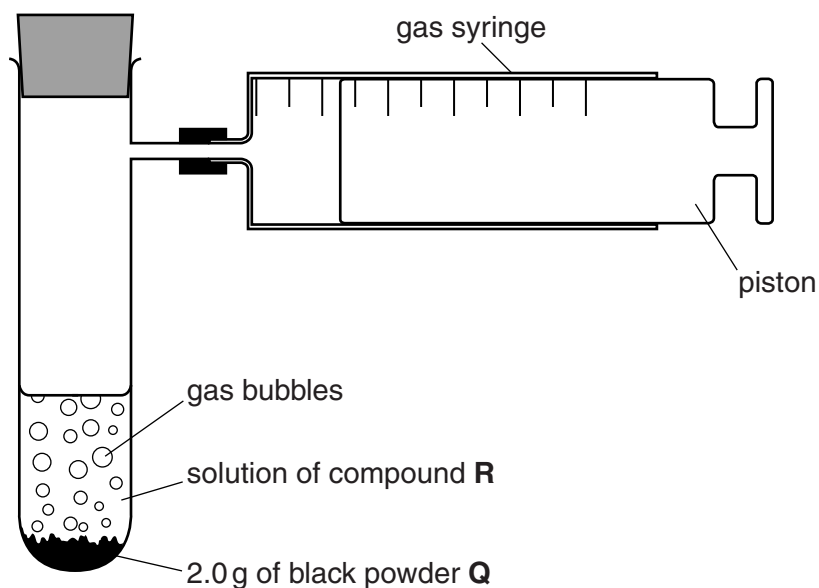

Fig. 7.1

The student measures the total volume of gas released during the reaction.

Her results are shown as a graph in Fig. 7.2 on page 18.

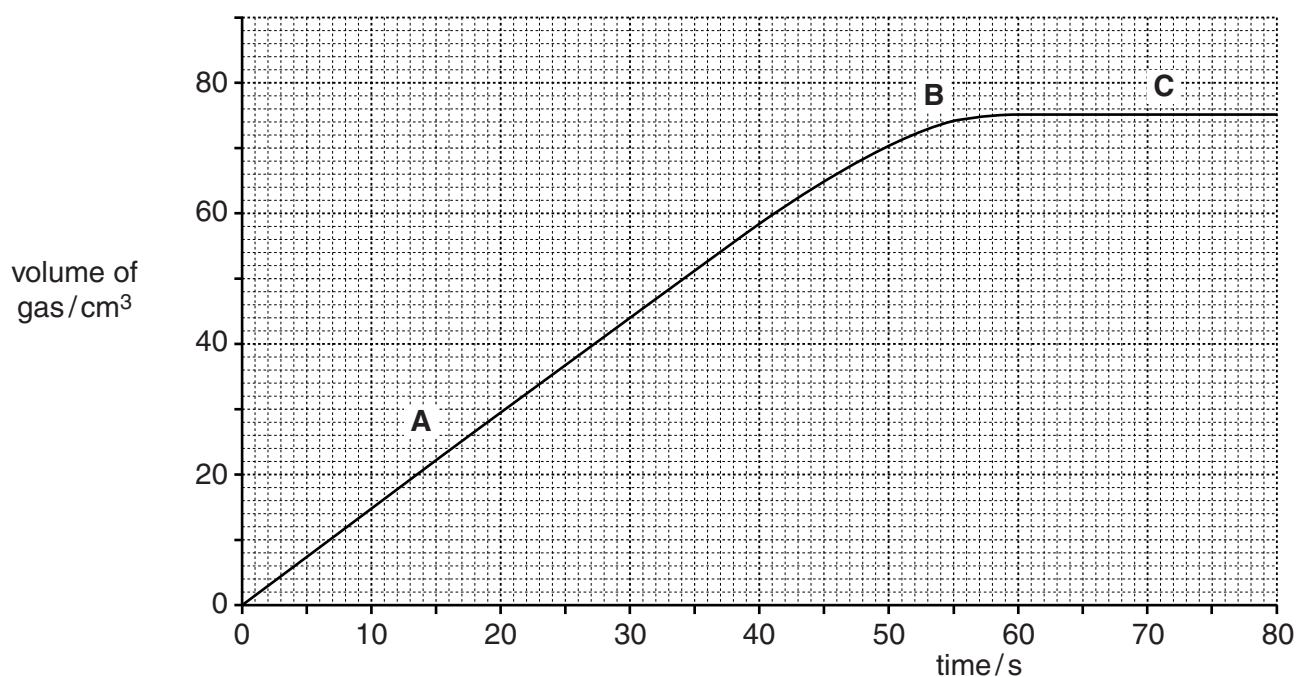

Fig. 7.2

- (i) State at which point, **A**, **B** or **C**, the speed of reaction is greatest.

Explain your answer.

point

explanation

.....[1]

- (ii) State the time taken for the reaction to finish.

.....[1]

- (iii) Explain your answer to (b)(ii).

.....

.....[1]

- (c) The student added exactly 2.0g of powder **Q** to the solution of **R** when she carried out her experiment.

The black powder **Q** is a catalyst for the decomposition of compound **R**.

State the mass of **Q** which remains when **R** has fully decomposed. Explain your answer.

mass of **Q** remaining g

explanation

.....

.....[2]

- (d) The student repeats the experiment using a solution of **R** that has a higher concentration.

Predict and explain, in terms of particle collisions, the effect this has on the speed of reaction.

.....

.....

.....

.....[3]

8 Fig. 8.1 shows the inside of a refrigerator.

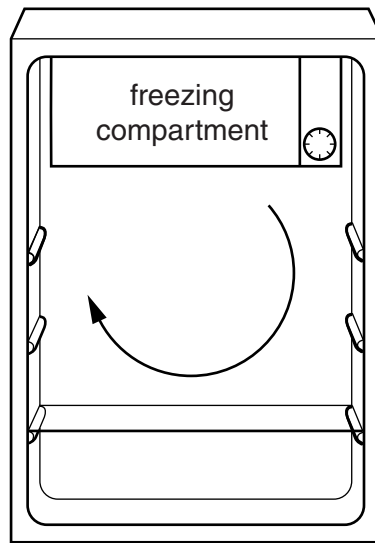

Fig. 8.1

(a) The air inside the refrigerator is cooled by convection.

The cold air moves downwards from the freezing compartment and displaces warm air which moves upwards.

Explain this movement in terms of particles.

.....

.....

.....[2]

- (b) Some ice has been made by freezing some water.

Fig. 8.2 shows the arrangement of the particles in a liquid and in a solid.

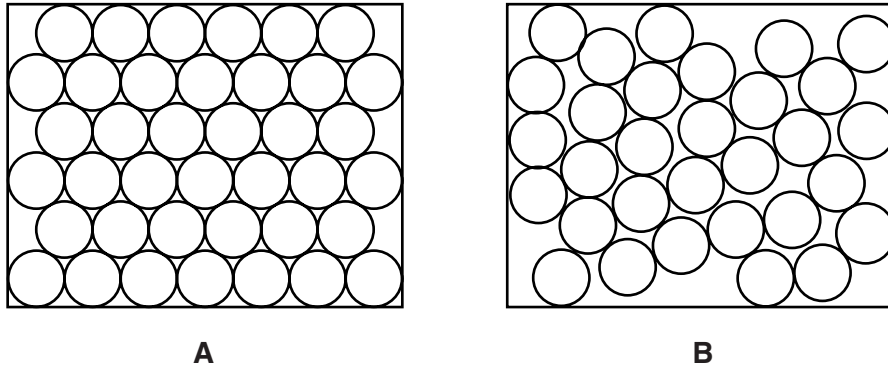

Fig. 8.2

Use the letters **A** or **B** from Fig. 8.2 to fill in the blank and complete the statement to explain your choice.

Diagram shows a liquid because the particles

.....

.....[2]

- (c) Some ice from the freezing compartment is allowed to melt at 0°C .

Explain why energy is required to melt the ice even though the temperature remains at 0°C .

.....

.....

.....[1]

- (d) The refrigerator has two lamps connected in parallel. The resistance of each lamp is $5500\ \Omega$.

Calculate the combined resistance of the two lamps.

State the formula you use and show your working.

formula

working

resistance = Ω [2]

- (e) The mass of air in the refrigerator is $0.20\ \text{kg}$. The air in the refrigerator is cooled by 15°C .

This removes $3.03\ \text{J}$ of thermal energy from the air.

Calculate the specific heat capacity of air.

State the formula you use and show your working.

formula

working

specific heat capacity = $\text{J/kg}^\circ\text{C}$ [2]

- 9 Table 9.1 shows information about some of the elements found in the second period of the Periodic Table.

Table 9.1

Group	IV	V	VI	VII	VIII
element symbol	C	N	O	F	Ne
proton number	6	7	8	9	10
relative atomic mass	12	14	16	19	20

- (a) (i) Explain the meanings of the following.

Carbon has a proton number of 6.

.....

Oxygen has a relative atomic mass of 16.

.....

[2]

- (ii) Calculate the relative molecular mass of fluorine, F_2 .

Show your working.

.....[1]

- (iii) State, in terms of atomic structure, which of the elements shown in Table 9.1 does **not** form compounds. Explain your answer.

.....

[2]

- (b) (i) Describe the arrangement of the electrons in a nitrogen atom. You may draw a diagram if it helps your answer.

.....
.....[2]

- (ii) Complete the covalent bonding diagram of a nitrogen molecule.

Your diagram should show only the electrons in the outer shells.

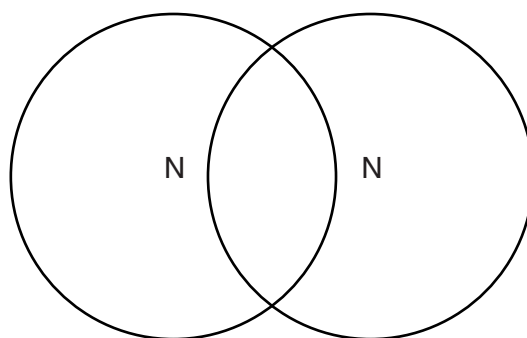

[2]

- 10 A student pinned a young bean plant to a cork board. The plant was on its side with light shining on it from above, as shown in Fig. 10.1.

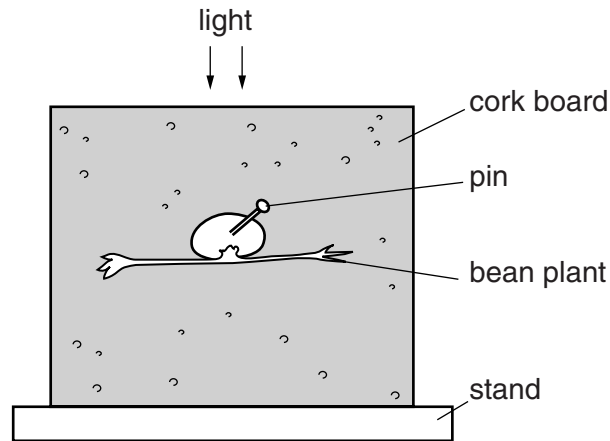

Fig. 10.1

Fig. 10.2 shows the appearance of the plant after two days.

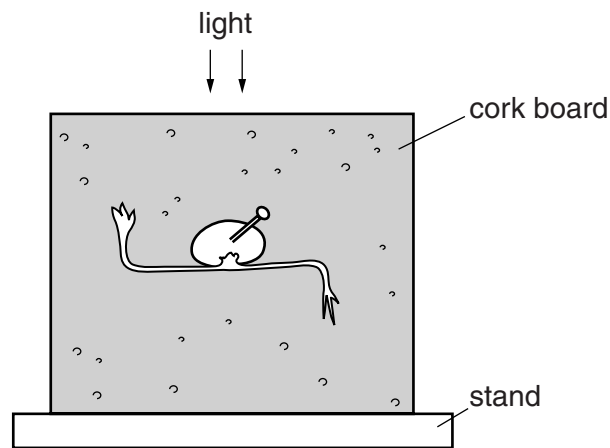

Fig. 10.2

- (a) The student's experiment demonstrated that the bean plant shows sensitivity.

Define the term *sensitivity*.

.....

.....

..... [2]

(b) The student concluded that his experiment showed that the plant stem responds to light by growing towards it.

(i) State the name for the type of response where a plant grows towards the light.

.....[1]

(ii) The student's experiment does **not** justify his conclusion. Explain why not.

.....
.....
.....[2]

(iii) Describe, in terms of auxins, what causes the plant stem to change its direction of growth.

.....
.....
.....[2]

11 An athlete is training for a race. He runs along a race track.

(a) Fig. 11.1 shows the speed/time graph for the athlete's run.

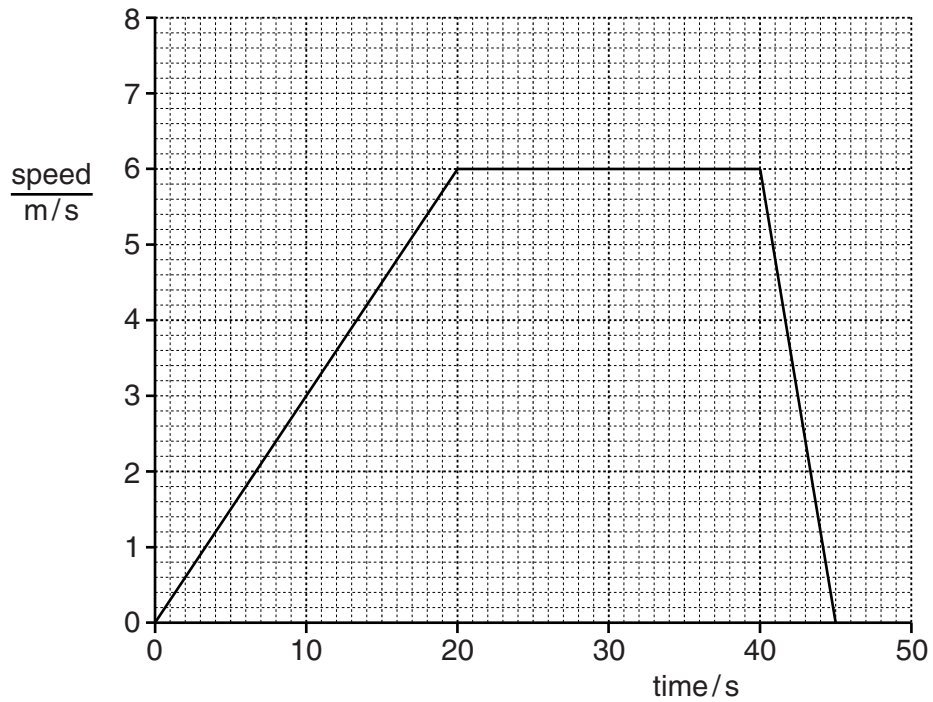

Fig. 11.1

(i) Calculate the distance travelled by the athlete.

Show your working.

distance = m [3]

- (ii) The mass of the athlete is 80 kg. Calculate the kinetic energy of the athlete when he is moving at his maximum speed.

State the formula you use and show your working.

formula

working

kinetic energy =J [2]

- (b) Fig 11.2 shows the athlete running at his maximum speed.

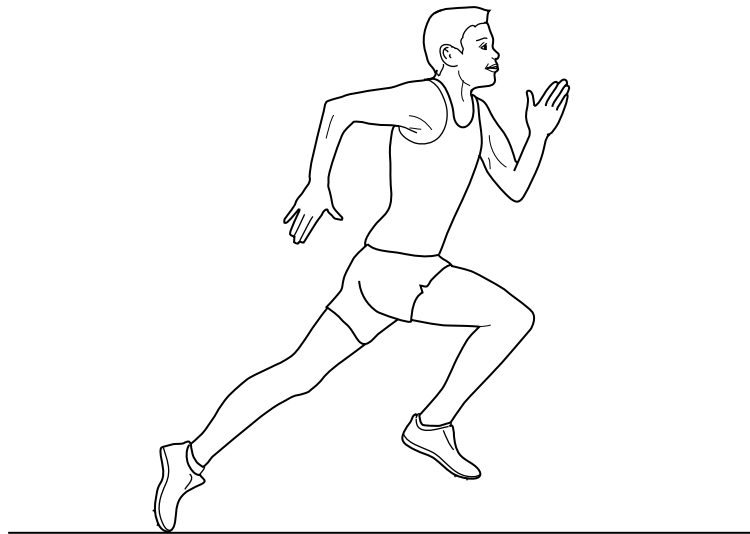

Fig. 11.2

Two forces acting on the athlete are his weight **A** and air resistance **B**, which slows the athlete.

Draw arrows on Fig. 11.2 to show the directions of these two forces. Label each force clearly using the letters **A** and **B**. [2]

12 Fig. 12.1 shows two processes, **L** and **M**, which are important in the petrochemical industry.

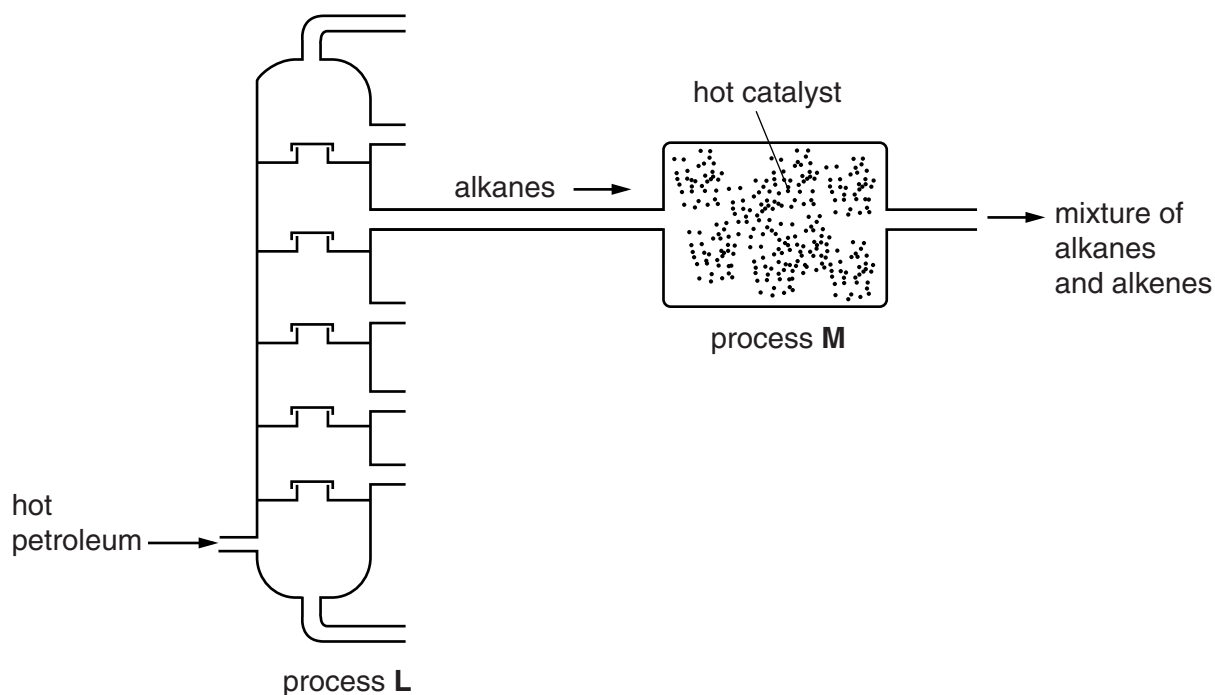

Fig. 12.1

(a) (i) Name processes **L** and **M**.

L

M

[2]

(ii) State **two** features of a typical alkane molecule.

1

2

[2]

(b) Complete the diagram to show the structure of a molecule of ethene.



[2]

(c) Bromine reacts with ethene to form a compound that has the formula $C_2H_4Br_2$.

(i) Name the type of chemical reaction that occurs between ethene and bromine.

.....[1]

(ii) The balanced equation for the reaction is shown.



State the colour, if any, of the compound that has the formula $C_2H_4Br_2$.

.....[1]

(iii) A solution of bromine contains 0.00625 moles of bromine molecules.

Calculate the mass of the compound $C_2H_4Br_2$ that is produced when this bromine reacts completely with excess ethene.

The relative atomic masses of the elements may be found in the Periodic Table on page 36.

Show your working.

mass = g [2]

(iv) Describe the reaction, if any, between bromine and **ethane**.

.....

.....[1]

13 Scientists have investigated the possibility of humans living on the planet Mars. To live on Mars people would need to grow plants on the planet.

(a) Explain why humans would be dependent on these plants.

.....
[1]

(b) Table 13.1 shows some of the conditions on Mars, compared to Earth.

Table 13.1

	Earth	Mars
distance from the Sun/millions of km	149.6	227.9
mean surface temperature/°C	14	-55
carbon dioxide in the atmosphere/%	0.03	95
availability of water	large amounts	traces

(i) Explain why the distance of the planet from the Sun would be important for plants growing on Mars.

.....

[2]

(ii) State how the carbon dioxide concentration of the atmosphere on Mars (compared to that on Earth) affects plant growth. Explain your answer.

.....

[1]

- (iii) If large numbers of plants were grown on Mars for a long period of time, predict how this might change the planet's atmosphere. Explain your answer.

change

.....
.....

explanation

.....
.....

[2]

BLANK PAGE

