



Cambridge International Examinations
Cambridge International General Certificate of Secondary Education

CANDIDATE
NAME

CENTRE
NUMBER

--	--	--	--	--

CANDIDATE
NUMBER

--	--	--	--

CO-ORDINATED SCIENCES

0654/61

Paper 6 Alternative to Practical

May/June 2018

1 hour

Candidates answer on the Question Paper.

No Additional Materials are required.

READ THESE INSTRUCTIONS FIRST

Write your Centre number, candidate number and name on all the work you hand in.

Write in dark blue or black pen.

You may use an HB pencil for any diagrams or graphs.

Do not use staples, paper clips, glue or correction fluid.

DO NOT WRITE IN ANY BARCODES.

Answer **all** questions.

Electronic calculators may be used.

You may lose marks if you do not show your working or if you do not use appropriate units.

At the end of the examination, fasten all your work securely together.

The number of marks is given in brackets [] at the end of each question or part question.

This document consists of **17** printed pages and **3** blank pages.

1 A student investigates an enzyme-catalysed reaction.

(a) Hydrogen peroxide is broken down by catalase, an enzyme found in living cells such as the cells of many types of bean.

Oxygen gas is released during the reaction.

Procedure

- The student places some bean puree into a measuring cylinder.
- He adds 10 cm³ hydrogen peroxide solution of concentration 1.5% to the measuring cylinder and then starts a stopclock. As oxygen gas is released, a foam is made in the mixture and the volume of the mixture in the measuring cylinder increases.
- He records the volume of the mixture in the measuring cylinder every 30 seconds for 5 minutes.

His results are shown in Table 1.1.

Table 1.1

time/seconds	volume of mixture/cm ³
30	16
60	22
90	27
120	33
150	39
180	43
210	46
240	48
270	50
300	50

3

(i) On the grid provided, plot a graph of volume of mixture (vertical axis) against time.

Label the axes.

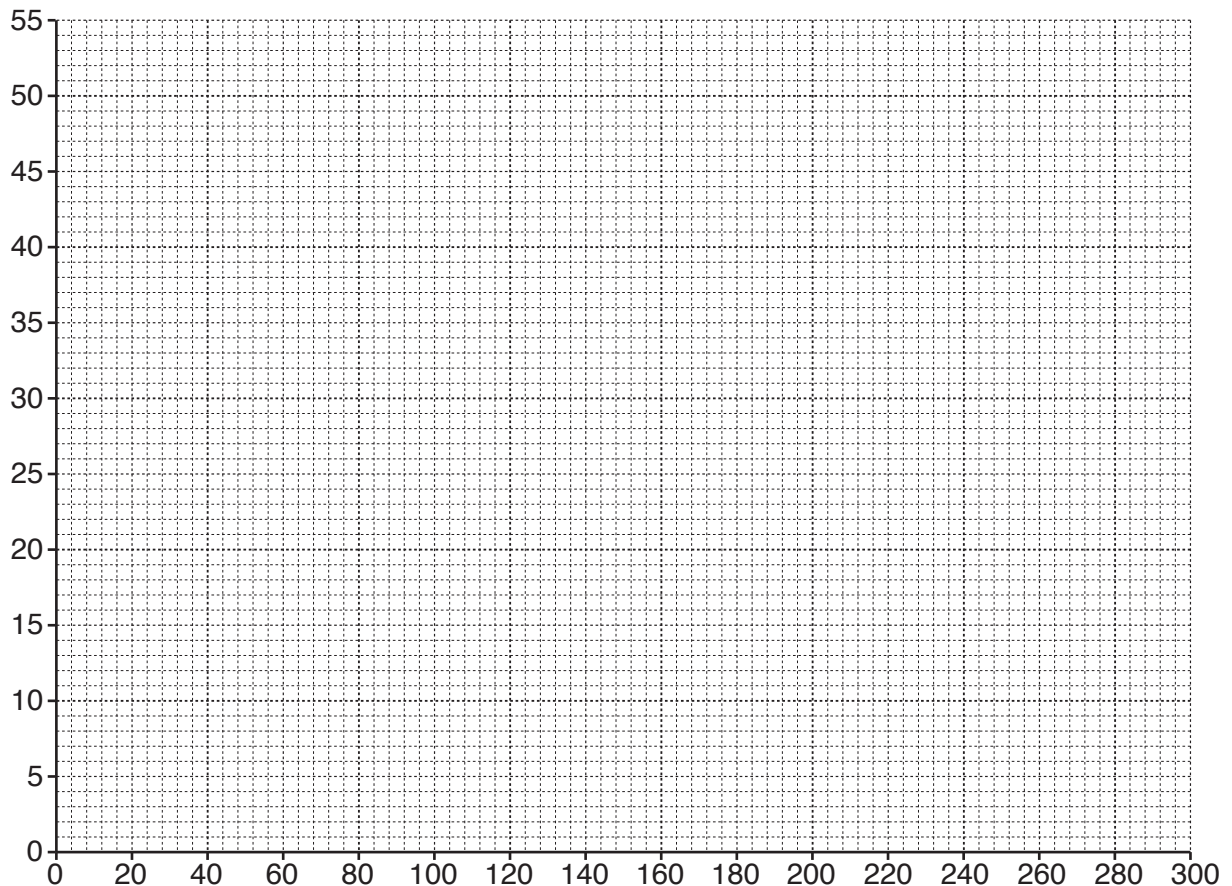

[2]

(ii) Draw the best-fit smooth curve.

[1]

(b) (i) Use your graph to predict the volume of the mixture at 200 seconds.

Show on your graph how you arrived at your answer.

volume = cm³ [1]

(ii) Use your graph to state how the rate of reaction changes during the 5 minutes.

.....[1]

(c) State **and** explain a safety precaution the student should have taken when carrying out the procedure in (a).

.....
[1]

(d) Plan an experiment, using the same method as in (a), to investigate the effect of changing the temperature of the hydrogen peroxide solution on the volume of the mixture.

In your answer, you should include

- variables you need to keep constant,
- suggestions for values of the variable you are going to change,
- how you would present your results on a graph.

.....

.....

.....

.....

.....

.....

.....[4]

2 A student is given three colourless solutions, **H**, **J** and **K**.

These three solutions are the halide solutions shown.

sodium bromide solution
sodium chloride solution
sodium iodide solution

The student does not know which solution is which.

He carries out tests to identify the solutions.

(a) Steps

- He places about 2 cm³ of solution **H** in a test-tube.
- He adds a few drops of silver nitrate solution.
- He then adds ammonia solution until the test-tube is nearly full.
- He stirs the mixture carefully.
- He records his observations in Table 2.1.

He repeats the above steps for solutions **J** and **K**.

Table 2.1

test	observations		
	solution H	solution J	solution K
add silver nitrate solution	white ppt.	cream coloured ppt.	pale yellow ppt.
then add excess ammonia solution and stir	ppt. dissolves to form colourless solution	ppt. dissolves slightly	ppt. remains unchanged

- (i) Use the observations in Table 2.1 to identify which solution, **H**, **J** or **K**, is sodium chloride solution.

Explain how you reached your identification.

sodium chloride solution is

explanation

[1]

- (ii) State **and** explain whether the addition of silver nitrate solution followed by excess ammonia solution can be used to distinguish between the three halide solutions, **H**, **J** and **K**.

.....

.....

.....[1]

(iii) Nitric acid is usually added to the unknown solution before adding silver nitrate solution.

Explain why adding nitric acid first is not necessary in this test for this investigation.

.....
[1]

(b) The student then adds chlorine water to separate samples of the three solutions, **H**, **J** and **K**.

He records his observations in Table 2.2.

Table 2.2

test	observations		
	solution H	solution J	solution K
add chlorine water	no visible change	solution becomes yellow	solution becomes very dark orange

(i) Use the observations in Table 2.2 to suggest which **two** solutions of **H**, **J** and **K** could be sodium bromide solution.

Explain your answer in terms of the reactions which take place.

sodium bromide solution could be..... or

explanation

.....[1]

(ii) Suggest **one** precaution that the student should take when using chlorine water.

.....
[1]

(iii) Describe another test that could be carried out on the two solutions you identified in (b)(i) to show which solution is sodium bromide and which solution is sodium iodide.

State the expected observations for sodium bromide solution and sodium iodide solution.

.....

[2]

- (c) A sample of sodium chloride solution can be made by reacting hydrochloric acid with sodium hydroxide solution.

Sodium hydroxide solution is added slowly to 25 cm^3 of hydrochloric acid in the presence of an indicator.

When the indicator changes colour, the volume of sodium hydroxide solution which has been added is recorded.

The reaction is then repeated using 25 cm^3 of hydrochloric acid and the recorded volume of sodium hydroxide solution but without the indicator.

- (i) Name a suitable piece of apparatus for measuring the volume of the sodium hydroxide solution.

.....[1]

- (ii) Explain why the reaction is repeated without the indicator.

.....

.....[1]

- (iii) Suggest a change to the experiment which would enable the volume of sodium hydroxide solution added to be determined more accurately.

.....

.....[1]

BLANK PAGE

3 A student investigates how the length l of a spring varies when different loads L are added to it.

(a) She sets up a spring in a clamp, as shown in Fig. 3.1.

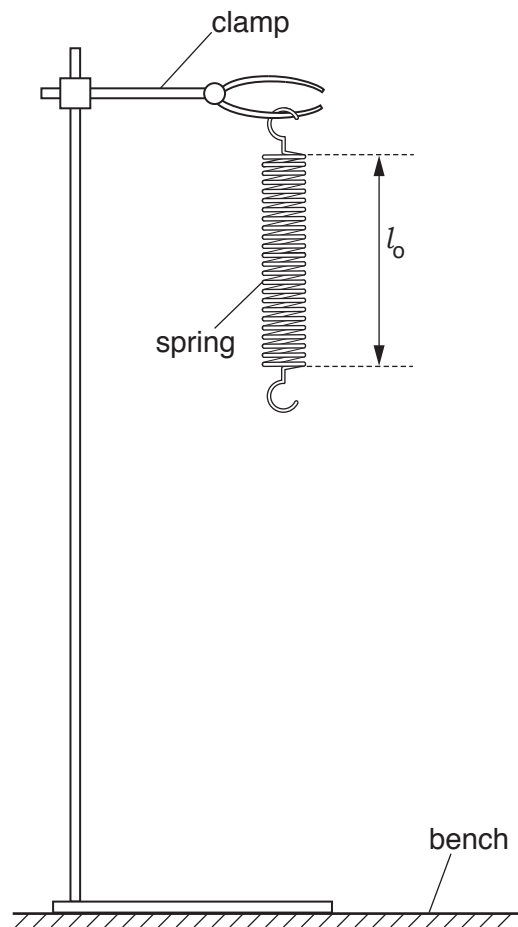

Fig. 3.1

(i) Measure and record the length l_0 of the unstretched spring to the nearest millimetre.

$l_0 = \dots\dots\dots$ mm [1]

(ii) State **one** precaution that the student takes to avoid a parallax (line-of-sight) error when measuring the length of the spring.

.....
[1]

- (b) She hangs a load L of 1.0N on the spring and measures, to the nearest millimetre, the new length l of the spring using a metre rule.

Part of the rule is shown in Fig. 3.2.

Use the rule in Fig. 3.2 to measure the new length l of the spring.

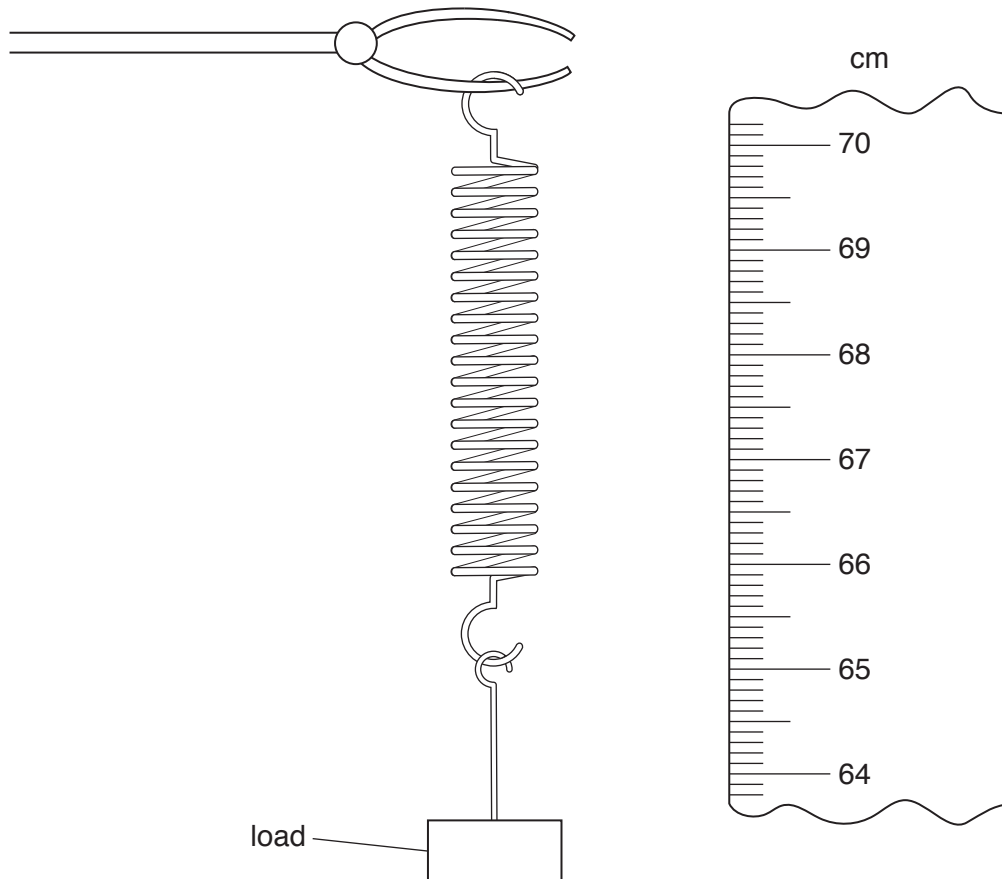

Fig. 3.2

Record this length in Table 3.1.

[2]

- (c) She repeats (b) using loads of 2.0N, 3.0N, 4.0N and 5.0N and completes Table 3.1.

Table 3.1

load L /N	spring length l /mm
1.0	
2.0	50
3.0	60
4.0	73
5.0	82

- (i) On the grid provided, plot a graph of L against l . Start both axes from the origin (0, 0).

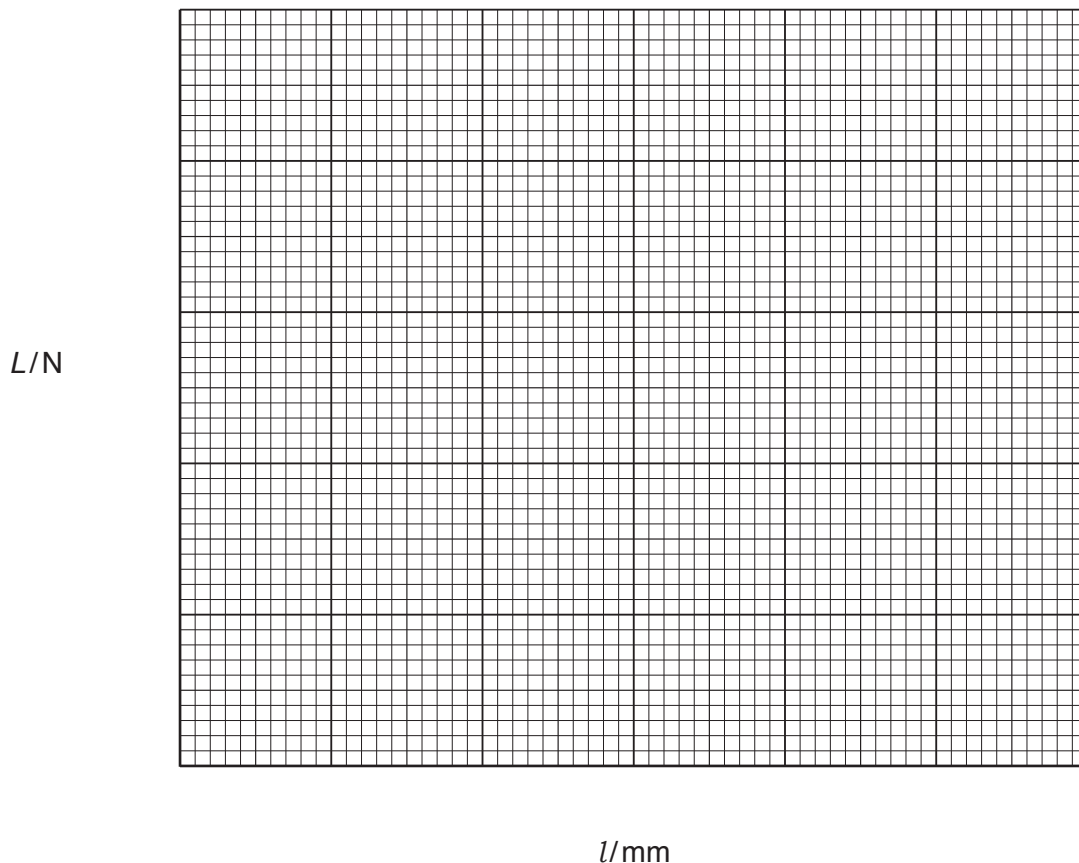

[2]

- (ii) Draw the best-fit straight line. [1]
- (iii) Use your graph to determine the length l_0 of the unstretched spring.

Show on your graph how you arrived at this value.

$$l_0 = \dots\dots\dots \text{ mm [1]}$$

- (d) Compare your answer in (a)(i) with your answer in (c)(iii).

State whether the answers agree within the limits of experimental accuracy.

Give a reason for your statement.

.....
 [1]

- (e) The gradient of your line measures the force constant of the spring. This is a measure of the elastic stiffness of the spring. The greater the force constant, the harder it is to stretch the spring.

On your graph, draw a line to show how the length of a spring with a greater force constant changes as loads are added to it. Label this line **M**. [1]

4 A student is studying cells.

Fig. 4.1 shows a photograph of some animal duodenum cells.

One of these cells is labelled cell A.

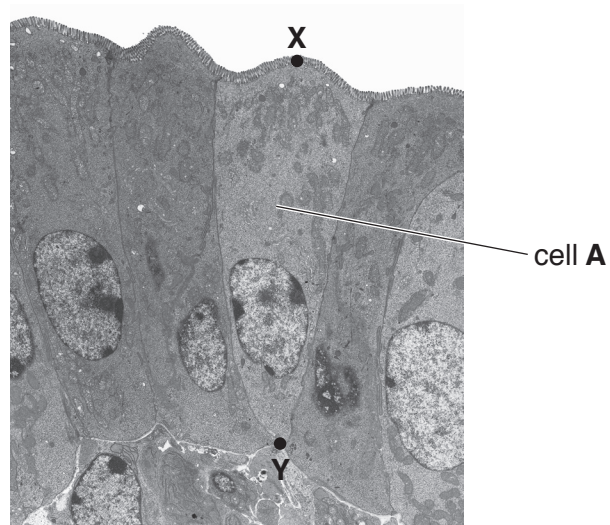
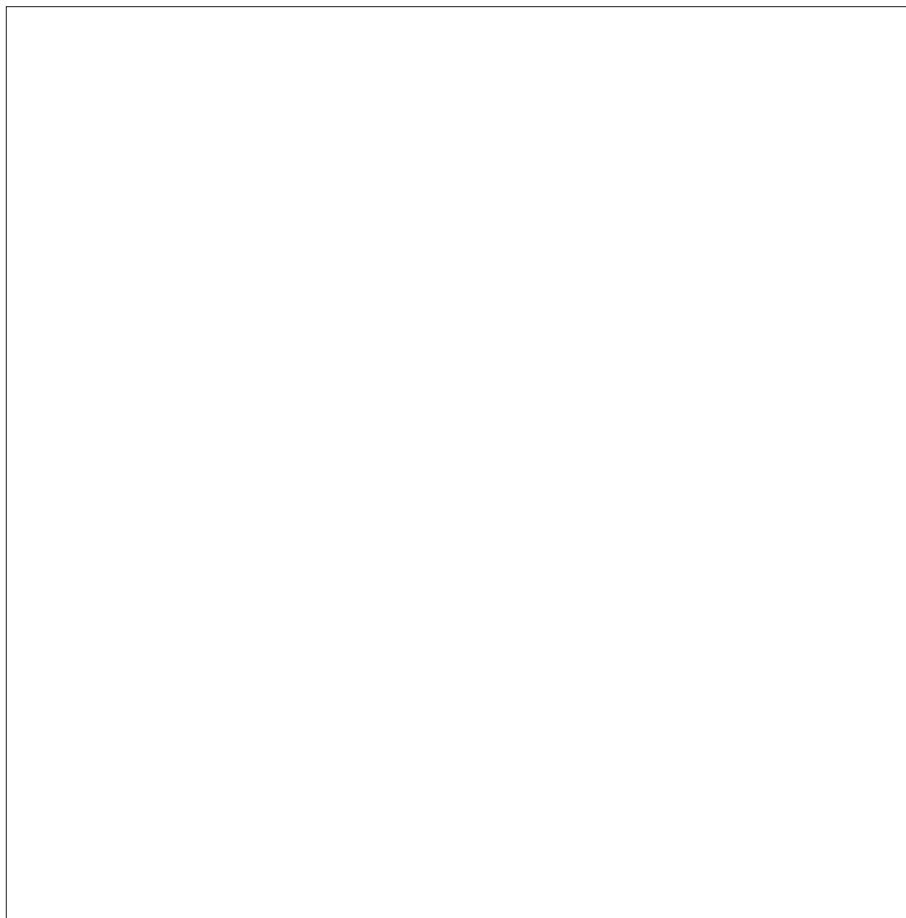

Fig. 4.1

(a) (i) In the box below, make an enlarged and detailed pencil drawing of cell A.



[3]

(ii) Draw a label line to label the nucleus of the cell in your drawing. [1]

(b) (i) Measure in millimetres, to the nearest millimetre, the length of cell **A** between points **X** and **Y** in Fig. 4.1.

length = mm [1]

(ii) Draw the line **X–Y** on your drawing in the same place as **X** and **Y** are shown in Fig. 4.1.

Measure this line, in millimetres, to the nearest millimetre.

length = mm [1]

(iii) Use your **two** measurements to calculate the magnification of your drawing.

Show your working in the space below.

magnification = [1]

(c) Describe how you could test cells in a liquid sample for the presence of fat.

reagents used and method

.....

.....

observation for a positive result

[3]

- 5 A student prepares a pure sample of blue copper sulfate crystals using copper carbonate powder and dilute sulfuric acid.

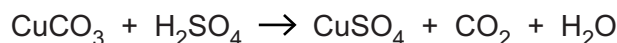

He plans his experiment in a series of steps labelled **A** to **F**.

Step **A**: Add copper carbonate to the acid a little at a time until no more reacts.

Step **B**: Heat the solution until half of the water has evaporated.

Step **C**: Dry the crystals in filter paper.

Step **D**: Filter the mixture.

Step **E**: Leave the basin to cool.

Step **F**: Measure 25 cm³ of sulfuric acid into a beaker.

The teacher says that all of the steps are correct but they are in the wrong order.

- (a) Using the letters, place the steps into the correct order. Steps 1 and 6 have been completed for you.

Step 1:^F.....

Step 2:

Step 3:

Step 4:

Step 5:

Step 6:^C.....

[3]

- (b) Suggest how the student would know when no more copper carbonate reacts.

.....[1]

(c) Draw a diagram of Step D. Label the apparatus and the substances.

[2]

(d) (i) Explain why the copper carbonate needs to be added until no more reacts.

.....
.....[1]

(ii) Explain why only half of the water is evaporated in Step B.

.....
.....[1]

(e) The student takes a few crystals of copper sulfate and dissolves them into water in a test-tube.

He adds a few drops of ammonia solution and stirs.

He continues adding the ammonia a few drops at a time until the ammonia is in excess.

Describe what the student observes in the test-tube.

.....
.....
.....
.....[2]

6 A student investigates the energy efficiency of a model railway.

He sets up an oval track of circumference 10m and places a train, consisting of a locomotive and three carriages, onto it as shown in Fig. 6.1.

The d.c. power supply is connected to the train track. The electricity goes from the power supply to the train and is then used to turn the motor in the train.

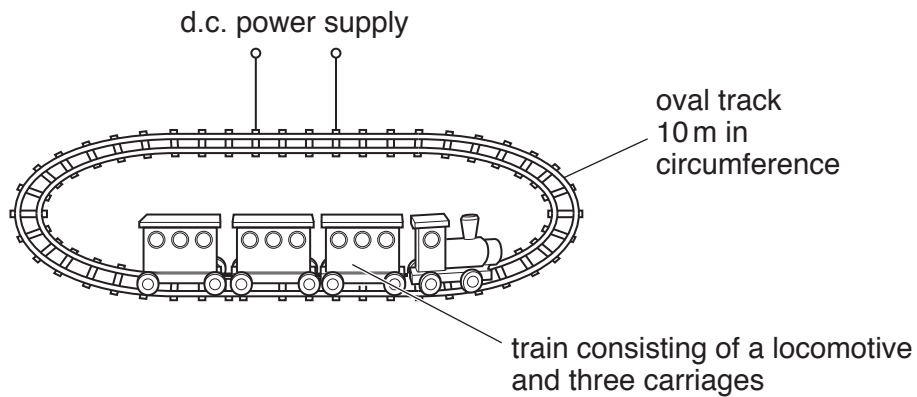

Fig. 6.1

(a) Complete the circuit diagram shown in Fig. 6.2 using appropriate circuit symbols, which include

- an ammeter to measure the current supplied to the train,
- a voltmeter to measure the potential difference of the power supply.

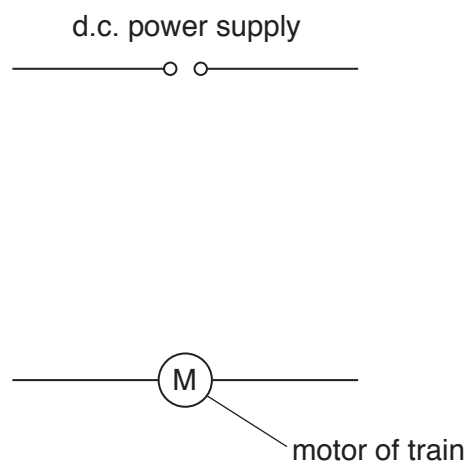

Fig. 6.2

[2]

- (b) The student switches on the power supply and waits until the train is running at a steady speed.

He measures the current I in the circuit, the potential difference V across the power supply and the time t it takes for the train to travel around the track once.

- (i) Fig. 6.3 shows the readings on the ammeter, the voltmeter and the timer.

Read and record these values, in the spaces below, to two significant figures.

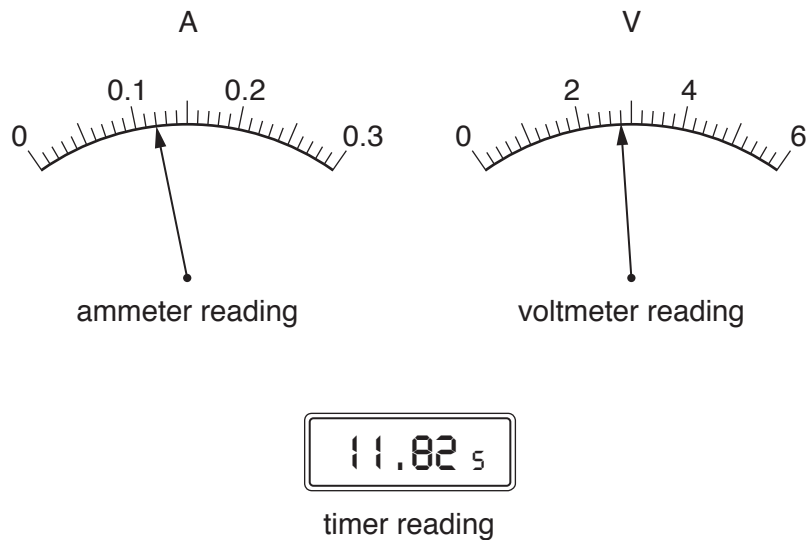

Fig. 6.3

current, $I =$ A

potential difference, $V =$ V

time, $t =$ s
[3]

- (ii) Calculate the electrical energy supplied to the train to complete one circuit of the track using the equation shown.

$$\text{electrical energy supplied} = I \times V \times t$$

electrical energy supplied to the train = J [1]

- (iii) The mass m of the train is 1.6 kg.

Calculate the kinetic energy of the train using the equation shown.

$$\text{kinetic energy} = \frac{50m}{t^2}$$

kinetic energy of the train = J [1]

- (iv) Calculate the efficiency of the train using the equation shown.

$$\text{efficiency} = \frac{\text{kinetic energy of the train}}{\text{electrical energy supplied to the train}} \times 100$$

efficiency =% [1]

- (c) Explain why the energy transfer is not 100% efficient.

.....
 [1]

- (d) Describe how the experiment could be modified to obtain a more accurate value for the time it takes the train to travel around the track.

.....
 [1]

BLANK PAGE

BLANK PAGE

Permission to reproduce items where third-party owned material protected by copyright is included has been sought and cleared where possible. Every reasonable effort has been made by the publisher (UCLES) to trace copyright holders, but if any items requiring clearance have unwittingly been included, the publisher will be pleased to make amends at the earliest possible opportunity.

To avoid the issue of disclosure of answer-related information to candidates, all copyright acknowledgements are reproduced online in the Cambridge International Examinations Copyright Acknowledgements Booklet. This is produced for each series of examinations and is freely available to download at www.cie.org.uk after the live examination series.

Cambridge International Examinations is part of the Cambridge Assessment Group. Cambridge Assessment is the brand name of University of Cambridge Local Examinations Syndicate (UCLES), which is itself a department of the University of Cambridge.