



# Cambridge IGCSE™

CANDIDATE  
NAME

CENTRE  
NUMBER

--	--	--	--	--

CANDIDATE  
NUMBER

--	--	--	--

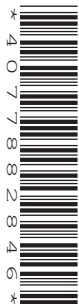

**CO-ORDINATED SCIENCES**

**0654/43**

Paper 4 Theory (Extended)

**May/June 2022**

**2 hours**

You must answer on the question paper.

No additional materials are needed.

## INSTRUCTIONS

- Answer **all** questions.
- Use a black or dark blue pen. You may use an HB pencil for any diagrams or graphs.
- Write your name, centre number and candidate number in the boxes at the top of the page.
- Write your answer to each question in the space provided.
- Do **not** use an erasable pen or correction fluid.
- Do **not** write on any bar codes.
- You may use a calculator.
- You should show all your working and use appropriate units.

## INFORMATION

- The total mark for this paper is 120.
- The number of marks for each question or part question is shown in brackets [ ].
- The Periodic Table is printed in the question paper.

This document has **36** pages. Any blank pages are indicated.

2

- 1 (a) Fig. 1.1 is a diagram of the female reproductive system.

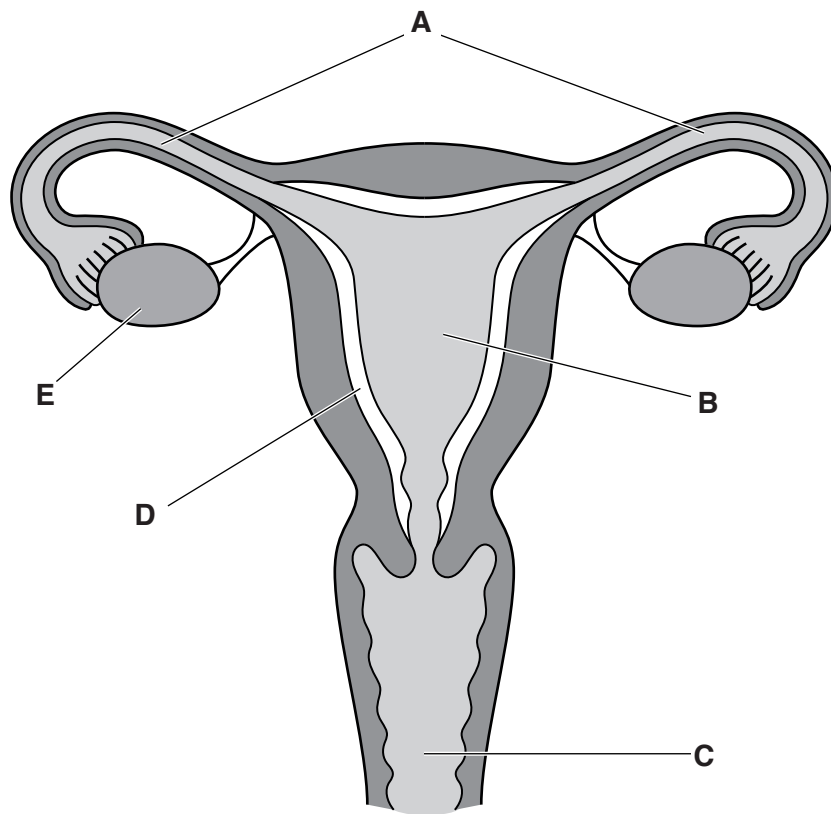

Fig. 1.1

Identify the letter from Fig. 1.1 that represents:

where female gametes are released .....

where fertilisation occurs .....

where implantation occurs .....

where meiosis occurs. ....

[4]

- (b) Female gametes in humans are called egg cells.

State the name of the male gamete in humans.

..... [1]

(c) Table 1.1 compares some features of male and female gametes.

Complete Table 1.1.

**Table 1.1**

	male gamete	female gamete
relative size		
number released at one time		usually one
motility		

[3]

(d) Complete the sentences to describe the adaptive features of egg cells.

One of the adaptive features of egg cells is that it has ..... stores.

The egg cell also has a ..... coating that changes after fertilisation.

[2]

[Total: 10]

2 Petroleum is a fossil fuel.

It can be separated into useful fractions by fractional distillation.

Fig. 2.1 shows a diagram of a fractionating column.

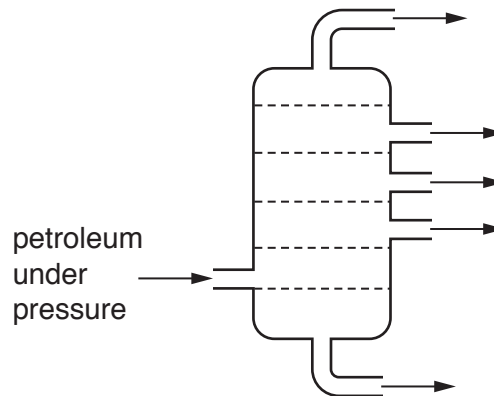

Fig. 2.1

(a) (i) Explain why it is possible to separate the substances in petroleum by fractional distillation.

.....  
 ..... [1]

(ii) On Fig. 2.1, write the letter **X** in the **coolest** part of the fractionating column. [1]

(b) Table 2.1 shows the uses of some of the fractions.

Complete Table 2.1.

Table 2.1

fraction	use
refinery gas	bottled gas for heating
gasoline	
naphtha	feedstock for making chemicals
diesel oil	
bitumen	

[3]

5

(c) Refinery gas contains propane,  $C_3H_8$ .

Draw a diagram to show the structure of propane.

[2]

(d) Refinery gas also contains butane,  $C_4H_{10}$ .

Butane burns in oxygen to make carbon dioxide and water.

Construct the balanced symbol equation for this reaction.

..... [2]

(e) Burning butane is a chemical change.

Describe the difference between a chemical change and a physical change.

.....  
..... [1]

[Total: 10]

- 3 (a) Fig. 3.1 shows a piece of graphite with an irregular shape.

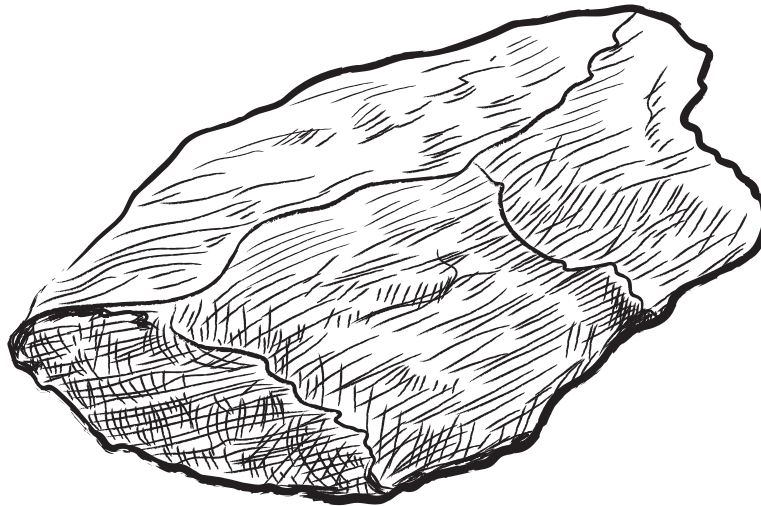

Fig. 3.1

- (i) Describe a method to determine the volume of the piece of graphite.

.....  
 .....  
 ..... [2]

- (ii) The piece of graphite has a mass of 33 g and a volume of 15 cm<sup>3</sup>.

Calculate the density of the piece of graphite.

density = ..... g/cm<sup>3</sup> [2]

- (b) Graphite can be used as a lubricant in machines with moving parts such as an electric drill.

- (i) Describe, in terms of forces and energy transfers, how lubricants increase the efficiency of a machine.

.....  
 .....  
 .....  
 ..... [3]

- (ii) An electric drill transfers 1200 J of electrical energy to 900 J of useful kinetic energy.  
Calculate the efficiency of the electric drill.

efficiency = ..... % [2]

- (iii) The electric motor in the drill has a current of 25 A when using an 18 V battery.  
Calculate the power output of the motor.

power = ..... W [2]

[Total: 11]

- 4 A student investigates the effect of temperature on the rate of photosynthesis.

Fig. 4.1 shows the apparatus they use.

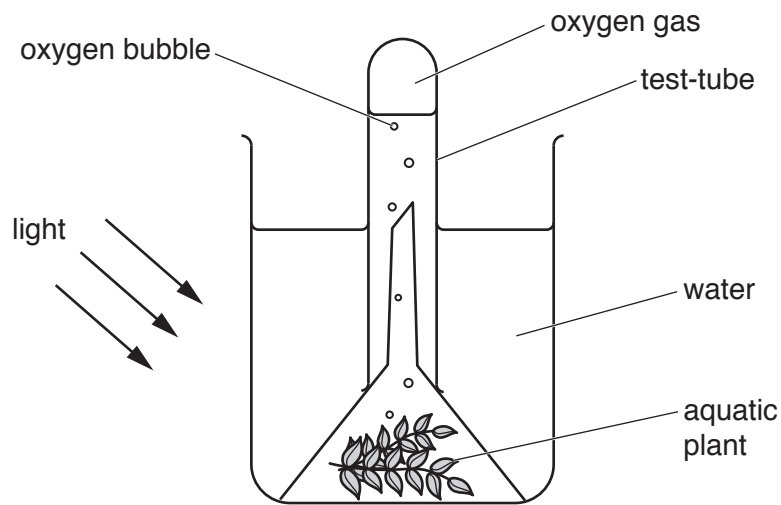

Fig. 4.1

The student counts the number of oxygen bubbles produced in one minute.

He repeats this investigation, changing the temperature of the water each time.

The number of oxygen bubbles produced per minute is equivalent to the rate of photosynthesis.

Table 4.1 shows the results.

Table 4.1

temperature / °C	number of bubbles produced per minute
0	0
5	4
10	8
15	13
20	16
25	18
30	19
35	8
40	0

- (a) State the temperature from Table 4.1 where the rate of photosynthesis is the highest.

..... °C [1]



(b) Photosynthesis is an enzyme-controlled reaction.

(i) Explain the results in Table 4.1 between 5 °C and 15 °C.

.....

.....

.....

.....

..... [3]

(ii) State the temperature from Table 4.1 when **all** the enzymes involved in photosynthesis are completely denatured.

..... °C [1]

(c) The carbohydrate glucose is also a product of photosynthesis.

Glucose is converted to different substances for transport and storage in a plant.

(i) Describe how carbohydrates are transported in a plant.

.....

.....

.....

..... [3]

(ii) State the larger molecule made from glucose that is used for storage in a plant.

..... [1]

(d) Chlorophyll is also necessary for photosynthesis.

State the energy transfer that chlorophyll is responsible for.

..... energy → ..... energy [2]

[Total: 11]

5 This question is about electrolysis.

(a) The list shows the particles found in aqueous copper(II) sulfate.



State the formula of **one** particle attracted to the **cathode** during electrolysis.

Choose from the list.

.....

[1]

(b) Aqueous copper(II) sulfate conducts electricity.

Explain why.

.....

.....

..... [2]

(c) Fig. 5.1 shows the apparatus used for the electrolysis of aqueous copper(II) sulfate.

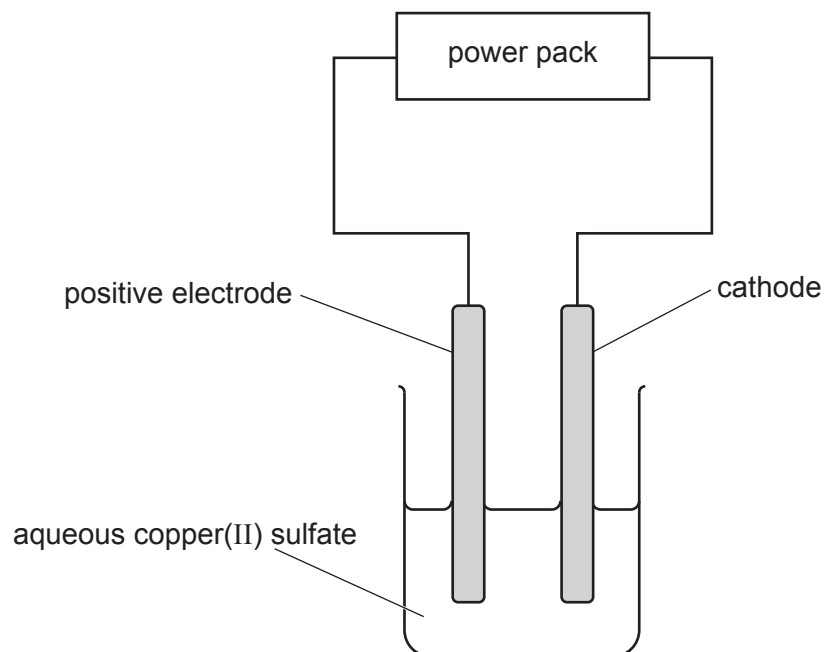

Fig. 5.1

(i) State the name given to the **positive** electrode.

..... [1]

(ii) The purification (refining) of copper uses electrolysis.

Describe how impure copper is purified by electrolysis.

Include ionic half-equations in your answer.

.....  
.....  
.....  
.....  
..... [4]

(d) Look at this ionic half-equation.



State if this reaction is an example of oxidation or reduction.

.....

Explain your answer.

.....

.....

[1]

[Total: 9]

6 Fig. 6.1 shows a cheetah.

Cheetahs are the fastest land animal and have a top speed of 30 m/s.

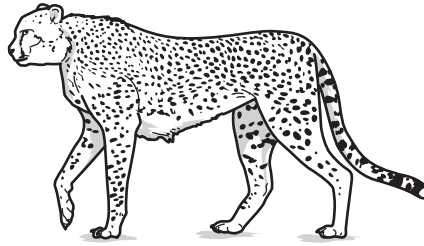

Fig. 6.1

(a) State the difference between speed and velocity.

.....  
 ..... [1]

(b) Fig. 6.2 shows a speed–time graph for a cheetah’s journey.

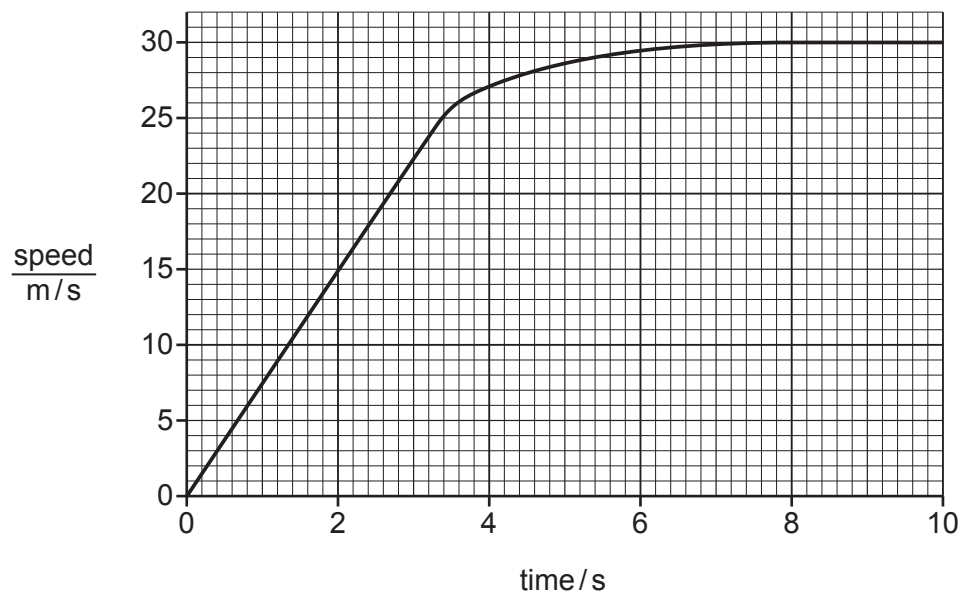

Fig. 6.2

Describe the motion of the cheetah shown in Fig. 6.2.

.....  
 .....  
 .....  
 .....  
 .....  
 ..... [3]

(c) The mass of the cheetah is 42 kg.

Calculate the kinetic energy of the cheetah when it is running at its maximum speed of 30 m/s.

kinetic energy = ..... J [2]

(d) A cheetah drinks water from a puddle.

Over time, the water in the puddle evaporates.

Evaporation and boiling both turn liquid water into a gas.

(i) State **one** difference between evaporation and boiling.

.....  
..... [1]

(ii) State two ways to increase the rate of evaporation from the puddle.

1 .....  
.....  
2 .....  
..... [2]

[Total: 9]

7 (a) The effect of an injection of adrenaline on pulse rate is recorded.

The adrenaline is injected at 1 minute.

Fig. 7.1 shows a graph of the results.

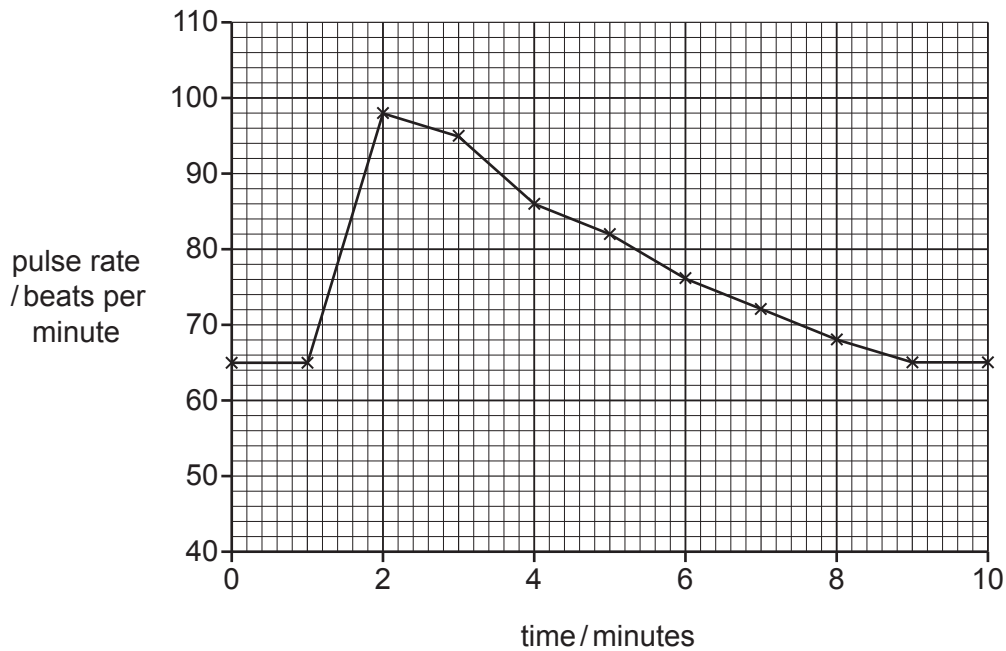

Fig. 7.1

(i) Identify in Fig. 7.1 the pulse rate before the adrenaline injection.

..... beats per minute [1]

(ii) Describe the immediate effect of the adrenaline injection on pulse rate shown in Fig. 7.1.

Use data from the graph to support your answer.

.....  
 .....  
 ..... [2]

(b) (i) State **one** effect adrenaline has on the eye.

..... [1]

(ii) Name the nerve that carries impulses from the eye to the brain.

..... [1]

(c) A hormone decreases blood glucose concentration by causing the glucose to be stored.

(i) State the name of the hormone that decreases blood glucose concentration.

..... [1]

(ii) State the name of the organ that produces this hormone.

..... [1]

(iii) State the name of the organ that stores the excess glucose.

..... [1]

(d) Describe two ways the **actions** of the hormonal system are different from the nervous system.

1 .....

.....

2 .....

.....

[2]

[Total: 10]





- 8 Fig. 8.1 shows the arrangement of ions in magnesium metal at 25°C.

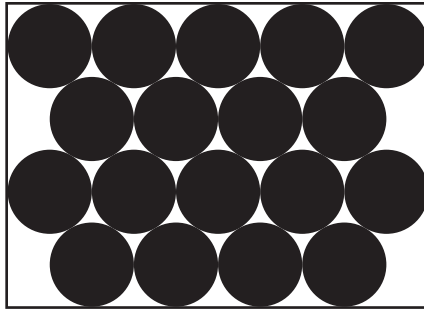

Fig. 8.1

- (a) Describe the changes in the arrangement and movement of magnesium ions when magnesium melts.

changes in **arrangement** of magnesium ions .....

.....

.....

changes in **movement** of magnesium ions .....

.....

.....

[2]

- (b) Magnesium melts at 650 °C and boils at 1090 °C.

In the box, draw the arrangement of ions in magnesium at 1800 °C.

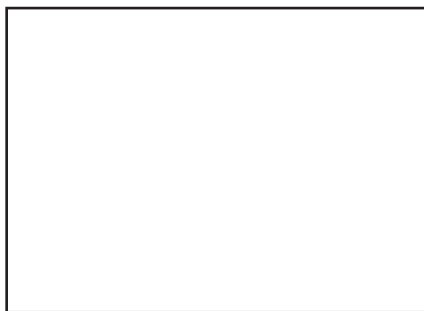

[1]

(c) Magnesium reacts with dilute hydrochloric acid. Hydrogen gas is made in the reaction.

A student investigates this reaction. Fig. 8.2 shows the apparatus he uses.

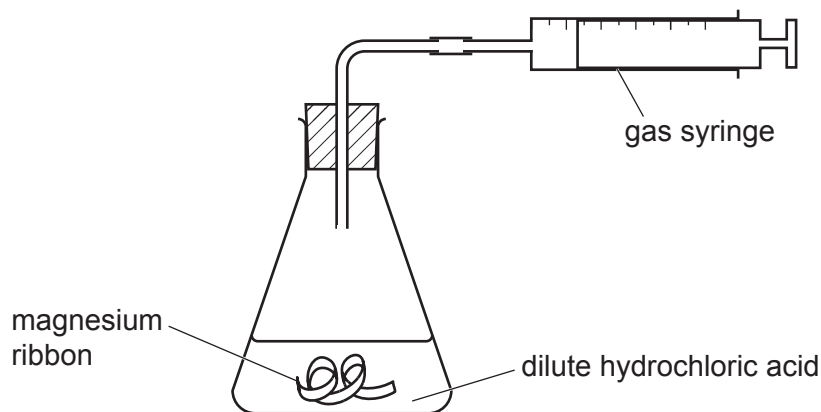

Fig. 8.2

Every 10 seconds, the student measures the total volume of hydrogen gas made.

Fig. 8.3 shows the graph the student plots of his results.

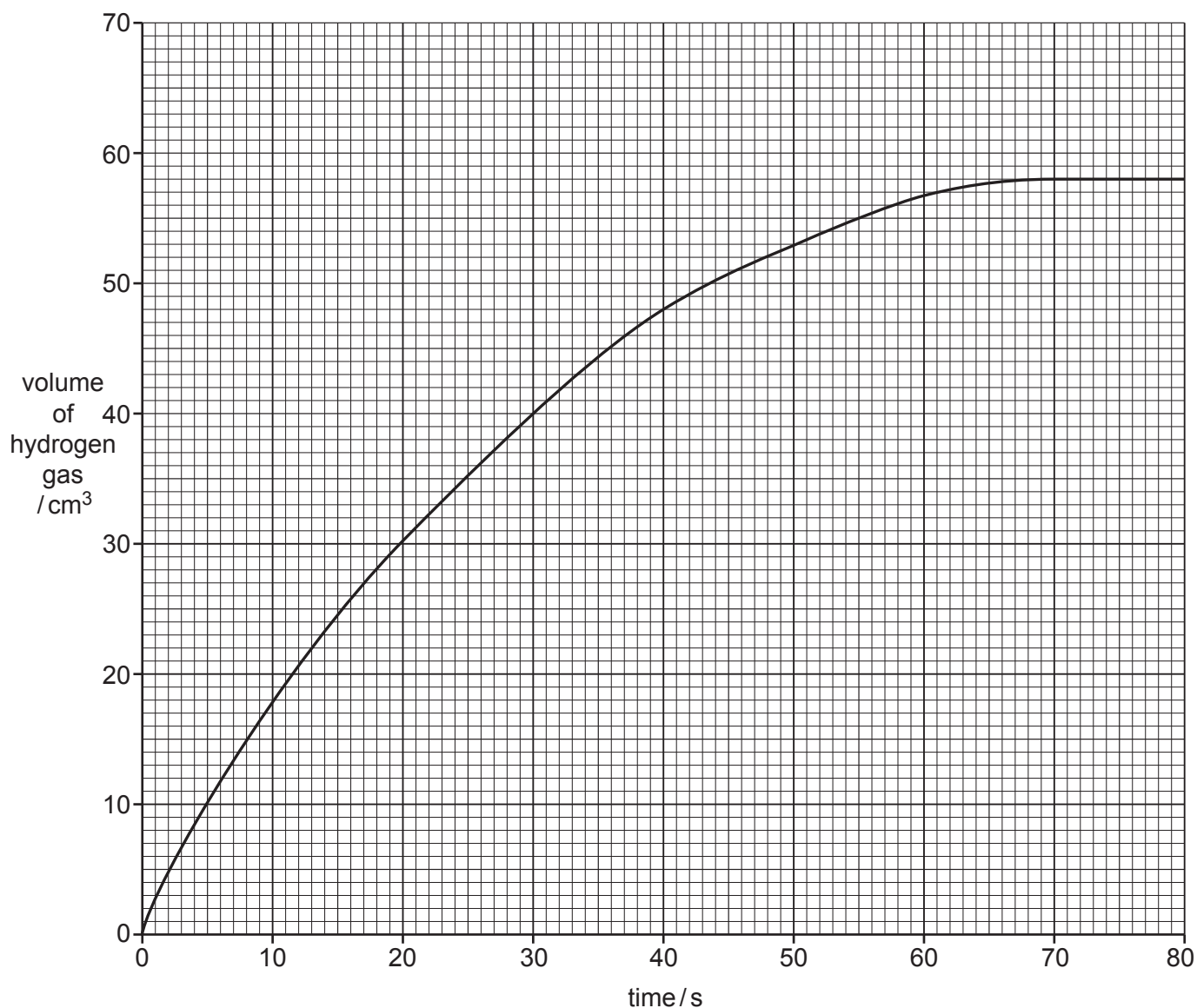

Fig. 8.3

- (i) State the volume of gas collected after 40 seconds.

volume of gas = ..... cm<sup>3</sup> [1]

- (ii) The reaction is **fastest** during the first 10 seconds.

Explain why.

.....  
 ..... [1]

- (iii) The student repeats the experiment.

He uses the same volume of hydrochloric acid and the same mass of magnesium.

This time he **increases the temperature** of the hydrochloric acid.

All of the magnesium reacts with the acid.

On Fig. 8.3, sketch the shape of the graph you would expect this time. [2]

- (d) The rate of the reaction can be increased by increasing the **concentration** of the dilute hydrochloric acid.

Explain why. Use ideas about collisions between particles.

.....  
 .....  
 ..... [2]

- (e) Magnesium chloride is also made in the reaction between magnesium and dilute hydrochloric acid.

Magnesium chloride contains the ions Mg<sup>2+</sup> and Cl<sup>-</sup>.

Determine the formula of magnesium chloride.

..... [1]

[Total: 10]



- 9 A student investigates the effect of changing light levels on the resistance of a light-dependent resistor (LDR).

The student shines a torch (flashlight) on to the LDR.

She then places glass slides between the LDR and the torch (flashlight) to reduce the light intensity (amount of light) reaching the LDR.

Fig. 9.1 shows the equipment she uses.

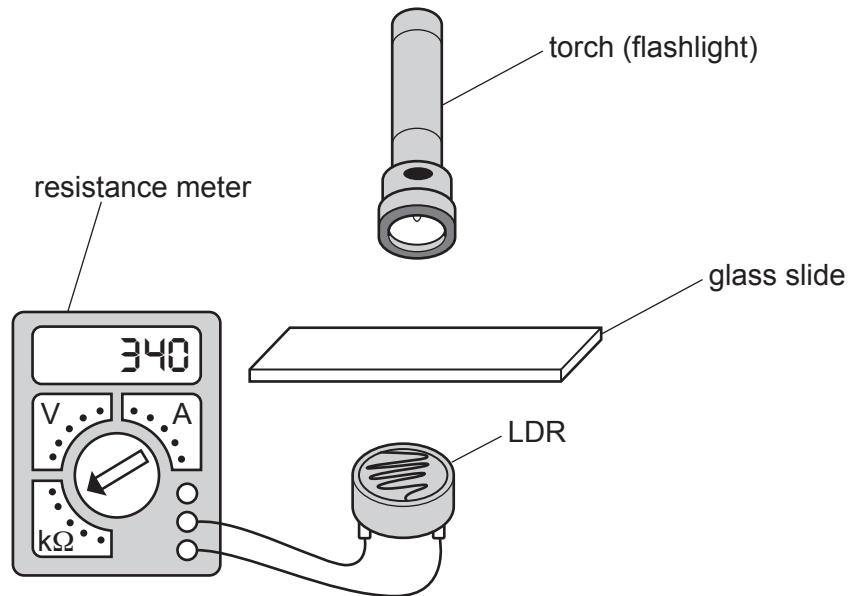
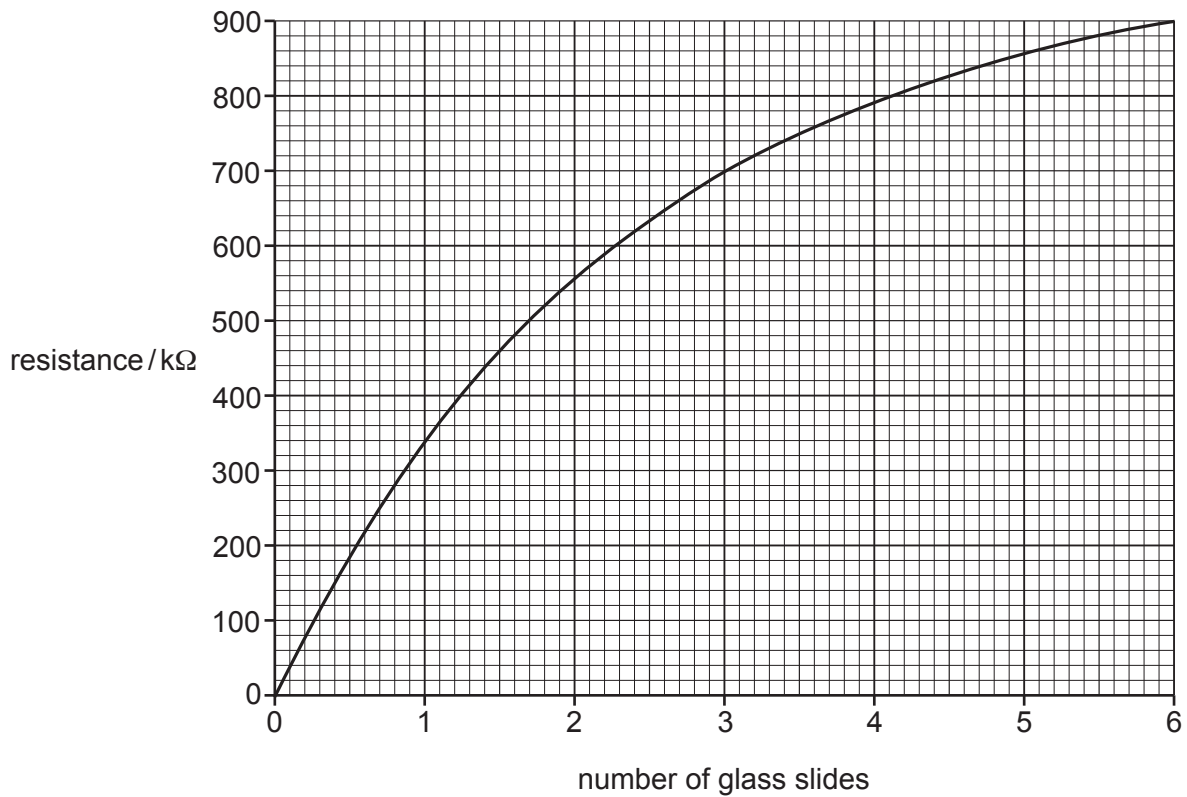

Fig. 9.1

The student places more glass slides between the torch (flashlight) and the LDR and measures the resistance, in kilo-ohms ( $k\Omega$ ), using a resistance meter.

(a) Fig. 9.2 shows a graph of the student's results.



**Fig. 9.2**

- (i) Use Fig. 9.2 to describe how the resistance of the LDR varies with changing light intensity.

.....  
 .....  
 .....  
 ..... [2]

- (ii) The resistance meter provides a potential difference (p.d.) of 14 V across the LDR.  
 Calculate the charge flowing through the LDR in 1 minute when 3 glass slides are used.

charge = ..... C [4]

(b) The lamp emits visible light at a frequency of  $5.0 \times 10^{14}$  Hz.

(i) State the meaning of the word frequency.

.....  
..... [1]

(ii) Calculate the wavelength of this visible light.

wavelength = ..... m [3]

(iii) State **one** form of electromagnetic radiation that has a frequency higher than visible light.

..... [1]

[Total: 11]

10 (a) The blood group of some patients in hospital is recorded.

Fig. 10.1 shows a bar chart of the results.

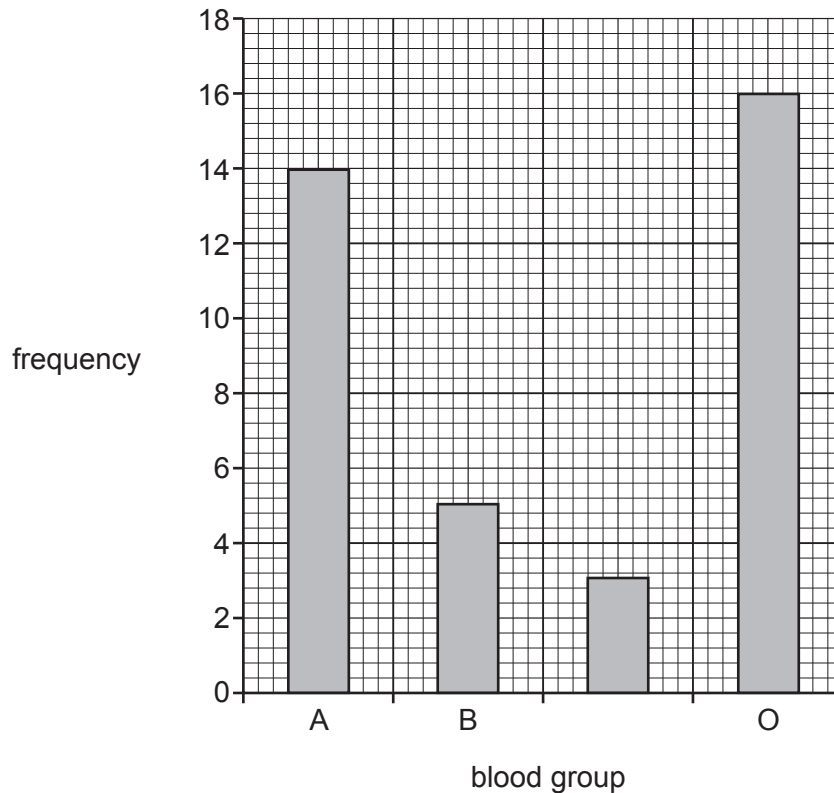

Fig. 10.1

(i) One of the blood groups in Fig. 10.1 is not labelled.

State this blood group.

..... [1]

(ii) Identify the most common blood group in Fig. 10.1.

..... [1]

(iii) Describe evidence from Fig. 10.1 that shows that this characteristic is an example of discontinuous variation.

.....  
 .....  
 ..... [2]

(iv) State the cause of the variation seen in Fig. 10.1.

..... [1]



(b) Adaptations in populations can be inherited through natural selection or selective breeding.

Table 10.1 compares some features of natural selection and selective breeding.

Complete Table 10.1 by placing ticks (✓) in the boxes to show the correct features.

**Table 10.1**

	involves passing on of alleles to offspring	is used to improve domesticated animals	occurs over many generations	keeps the features best suited to the environment
natural selection				
selective breeding				

[2]

(c) Sexual reproduction is involved in both natural selection and selective breeding.

State two **disadvantages** of sexual reproduction to a population of species in the wild.

1 .....

.....

2 .....

.....

[2]

[Total: 9]

11 Sulfuric acid is made by the Contact process.

Sulfur, air and water are raw materials used to make sulfuric acid.

Look at the equations for the first two stages in the Contact process.

**stage 1** ..... + .....  $\rightarrow$  sulfur dioxide

**stage 2** sulfur dioxide + oxygen  $\rightleftharpoons$  sulfur trioxide

(a) Complete the word equation for **stage 1** of the Contact process. [2]

(b) The conditions used for **stage 2** are:

- 450 °C
- atmospheric pressure
- a catalyst.

(i) State the name of the catalyst used.

..... [1]

(ii) Explain why a catalyst and a temperature of 450 °C are used in **stage 2** of the Contact process.

Use ideas about:

- the percentage of sulfur trioxide made
- the rate of reaction.

**catalyst**

percentage of sulfur trioxide made .....

.....

rate of reaction .....

.....

**450 °C**

percentage of sulfur trioxide made .....

.....

rate of reaction .....

.....

[4]

(c) The reaction in **stage 2** of the Contact process is exothermic.

Fig. 11.1 shows the energy level diagram for the reaction.

Complete the labels on Fig. 11.1.

Choose the labels from the list.

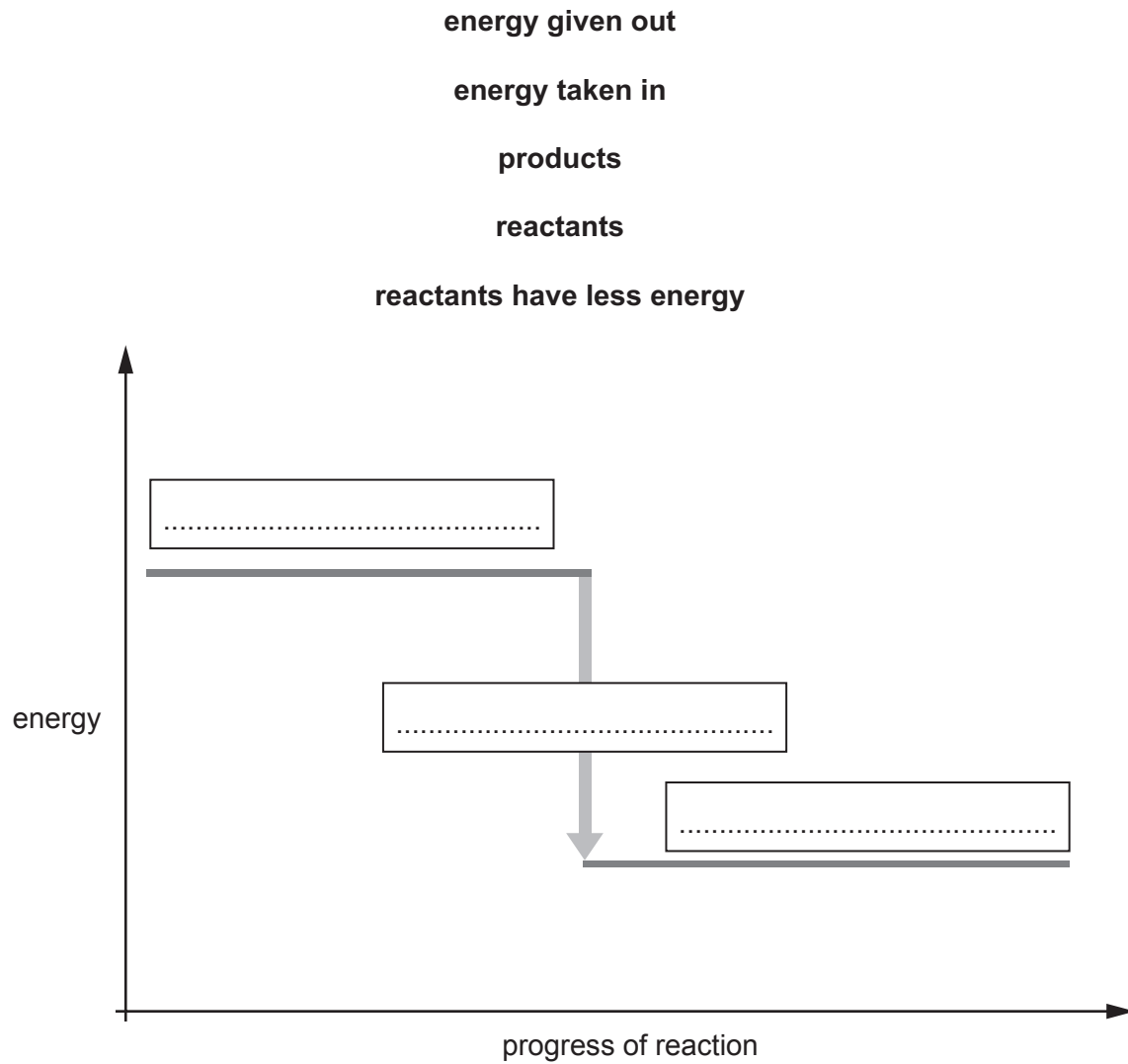

**Fig. 11.1**

[2]

28

(d) In an experiment, 200 g of sulfur trioxide,  $\text{SO}_3$ , is made.

Calculate the volume occupied by 200 g of sulfur trioxide gas.

The relative molecular mass,  $M_r$ , of sulfur trioxide is 80.

The volume of one mole of any gas is  $24 \text{ dm}^3$  at room temperature and pressure (r.t.p.).

Show your working.

volume = .....  $\text{dm}^3$  [2]

[Total: 11]

**BLANK PAGE**

12 Fig. 12.1 shows a forklift truck lifting a crate.

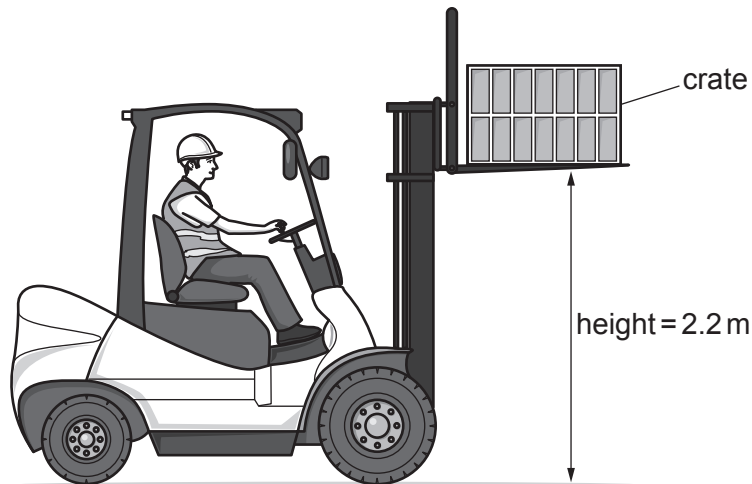

Fig. 12.1

- (a) The forklift truck does 2750 J of work on the crate when the crate is lifted through a height of 2.2 m.

The gravitational field strength,  $g$ , is 10 N/kg.

Calculate the mass of the crate.

mass = ..... kg [2]

- (b) Fig. 12.2 shows the same forklift truck after it has lowered the crate.



Fig. 12.2

Explain why the forklift truck is more stable after it has lowered the crate.

Use ideas about centre of mass in your answer.

.....  
 ..... [1]

(c) The forklift truck uses an electric motor to lift the crate.

Fig. 12.3 shows a simple d.c. motor.

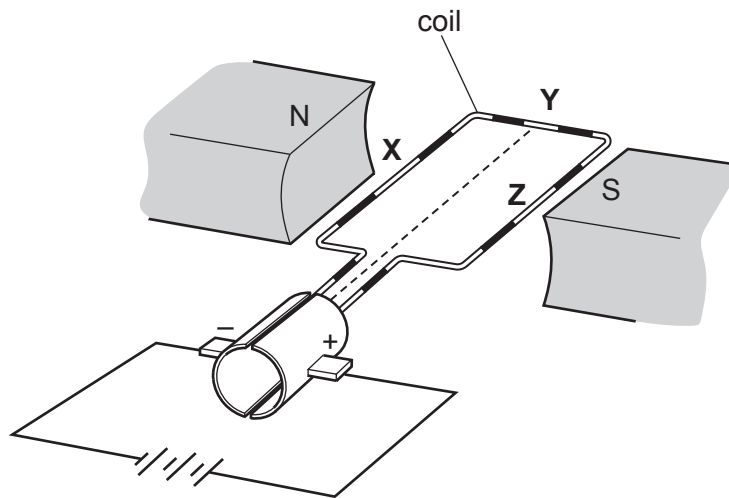

Fig. 12.3

(i) A current flows through the coil.

Draw arrows on Fig. 12.3 to show the direction of the force acting on points **X** and **Z** on the coil. [1]

(ii) State why point **Y** does not experience a force.

.....  
 ..... [1]

(d) A  $\beta$ -particle passes between the poles of a permanent magnet.

(i) Suggest why a  $\beta$ -particle is deflected when moving through a magnetic field.

.....  
 .....  
 .....  
 ..... [2]

(ii) State **and** explain how the deflection direction of an  $\alpha$ -particle would differ from that of the  $\beta$ -particle.

.....  
 .....  
 .....  
 ..... [2]

[Total: 9]

BLANK PAGE



BLANK PAGE



**BLANK PAGE**

---

Permission to reproduce items where third-party owned material protected by copyright is included has been sought and cleared where possible. Every reasonable effort has been made by the publisher (UCLES) to trace copyright holders, but if any items requiring clearance have unwittingly been included, the publisher will be pleased to make amends at the earliest possible opportunity.

To avoid the issue of disclosure of answer-related information to candidates, all copyright acknowledgements are reproduced online in the Cambridge Assessment International Education Copyright Acknowledgements Booklet. This is produced for each series of examinations and is freely available to download at [www.cambridgeinternational.org](http://www.cambridgeinternational.org) after the live examination series.

Cambridge Assessment International Education is part of Cambridge Assessment. Cambridge Assessment is the brand name of the University of Cambridge Local Examinations Syndicate (UCLES), which is a department of the University of Cambridge.

