



Cambridge IGCSE™

CO-ORDINATED SCIENCES

0654/11

Paper 1 Multiple Choice (Core)

October/November 2022

45 minutes

You must answer on the multiple choice answer sheet.

You will need: Multiple choice answer sheet
Soft clean eraser
Soft pencil (type B or HB is recommended)

INSTRUCTIONS

- There are **forty** questions on this paper. Answer **all** questions.
- For each question there are four possible answers **A, B, C** and **D**. Choose the **one** you consider correct and record your choice in soft pencil on the multiple choice answer sheet.
- Follow the instructions on the multiple choice answer sheet.
- Write in soft pencil.
- Write your name, centre number and candidate number on the multiple choice answer sheet in the spaces provided unless this has been done for you.
- Do **not** use correction fluid.
- Do **not** write on any bar codes.
- You may use a calculator.

INFORMATION

- The total mark for this paper is 40.
- Each correct answer will score one mark.
- Any rough working should be done on this question paper.
- The Periodic Table is printed in the question paper.

This document has **16** pages. Any blank pages are indicated.



- 1 Which characteristic of living organisms involves chemical reactions that break down nutrient molecules to release energy?
- A excretion
 - B nutrition
 - C reproduction
 - D respiration
- 2 What is the formula for magnification?
- A $\frac{\text{actual size}}{\text{image size}}$
 - B $\frac{\text{actual size}}{\text{image size}} \times 100$
 - C $\frac{\text{image size}}{\text{actual size}}$
 - D $\frac{\text{image size}}{\text{actual size}} \text{ mm}$
- 3 Glycerol is a component of which large molecules?
- A fats
 - B glycogen
 - C proteins
 - D starch
- 4 Which elements can be found in an enzyme molecule?
- 1 carbon
 - 2 nitrogen
 - 3 oxygen
- A 1, 2 and 3 B 1 and 3 only C 1 only D 2 only

5 Which row is correct for photosynthesis?

	raw materials	products
A	carbon dioxide and glucose	oxygen and water
B	carbon dioxide and water	oxygen and glucose
C	oxygen and glucose	carbon dioxide and water
D	oxygen and water	carbon dioxide and glucose

6 Dogs are mammals and have the same types of teeth as humans.

Which tooth is a canine?

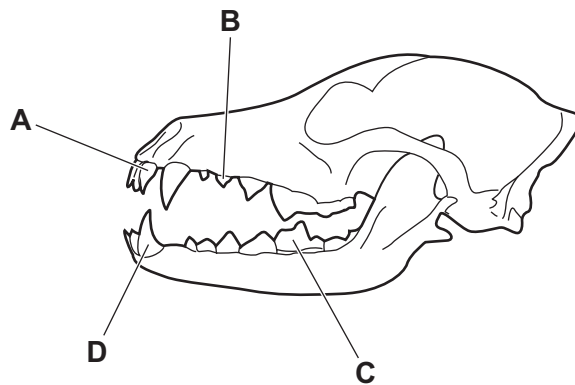

7 The diagrams represent sections through a root, a stem and a leaf mid-rib, not drawn to the same scale.

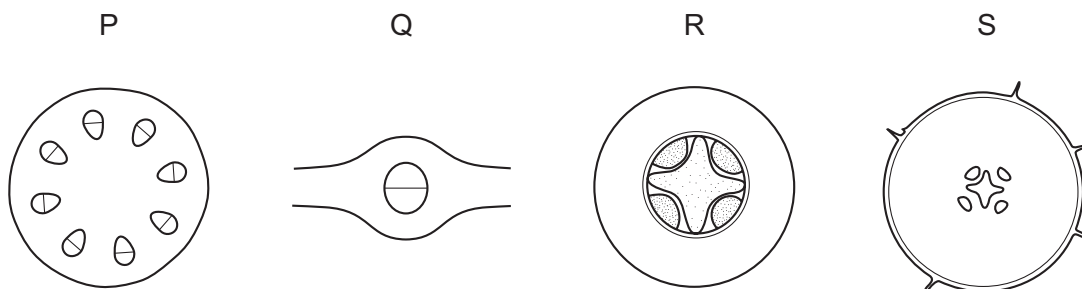

In which row are the sections correctly identified?

	root	stem	leaf
A	P	S	R
B	Q	R	S
C	R	P	Q
D	S	Q	P

- 8 The diagram shows apparatus used to investigate respiration of blowfly larvae.

Air is sucked through the solutions of hydrogencarbonate indicator as shown.

Hydrogencarbonate indicator turns orange with carbon dioxide at atmospheric concentration. It turns yellow with high carbon dioxide concentration.

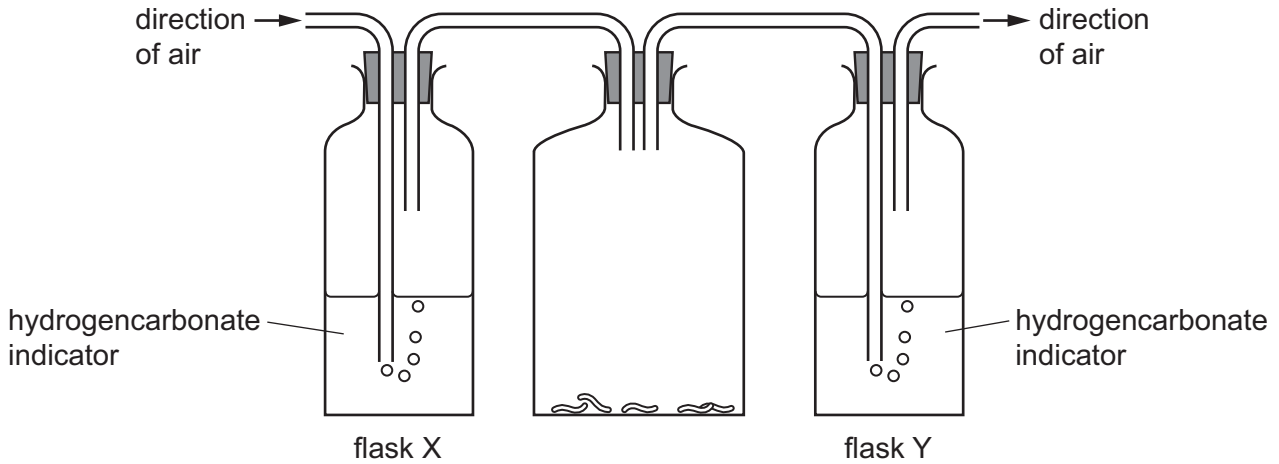

What are the colours of the hydrogencarbonate indicator in the flasks after 24 hours?

	flask X	flask Y
A	orange	orange
B	orange	yellow
C	yellow	orange
D	yellow	yellow

- 9 When a seed germinates in the soil, the root grows downwards.

Which type of response is the root exhibiting?

- A** negative gravitropism
- B** negative phototropism
- C** positive gravitropism
- D** positive phototropism

- 10 The graph shows the change in number of new HIV infections and deaths from AIDS between 1990 and 2014.

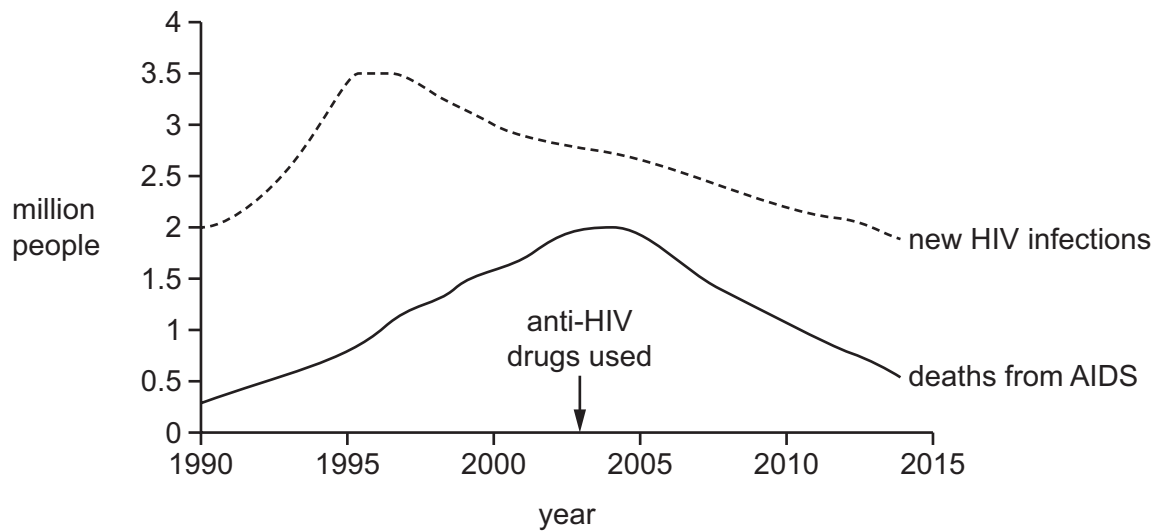

What does the graph show?

- 1 The number of new HIV infections fell after condom use was promoted.
- 2 The use of anti-HIV drugs has led to a decrease in deaths from AIDS.
- 3 The highest rate of deaths from AIDS occurred in 1995.

A 1 and 2 only **B** 3 only **C** 1, 2 and 3 **D** 2 only

- 11 Which sex chromosomes are found in a healthy male human?

A XO **B** XX **C** XY **D** YY

- 12 Which type of organism gets its energy from the remains of dead organisms or other organic waste?

A a carnivore
B a decomposer
C a herbivore
D a producer

- 13 What is an undesirable effect of deforestation?

A It increases the oxygen concentration of the atmosphere.
B It leads to erosion and loss of soil.
C It makes land available for agriculture.
D It pollutes the air with methane.

14 Which properties are used to distinguish between solids and gases?

1 compressibility

2 melting point

3 flammability

A 1 and 2 only B 1 and 3 only C 2 and 3 only D 1, 2 and 3

15 An atom of fluorine is represented by ${}^{19}_{9}\text{F}$.

How many electrons does this atom contain?

A 9 B 10 C 19 D 28

16 Hydrogen reacts with oxygen to produce water.

What is the balanced equation for this reaction?

A $\text{H}_2 + \text{O}_2 \rightarrow \text{H}_2\text{O}$

B $\text{H}_2 + \text{O}_2 \rightarrow 2\text{H}_2\text{O}$

C $\text{H}_2 + \text{O} \rightarrow \text{H}_2\text{O}$

D $2\text{H}_2 + \text{O}_2 \rightarrow 2\text{H}_2\text{O}$

17 Which process is used to produce sodium and chlorine from the compound sodium chloride?

A chromatography

B cracking

C distillation

D electrolysis

- 18 Equal amounts of substances W, X, Y and Z are reacted separately with equal amounts of dilute acid.

The following temperature changes are recorded.

substance	temperature change / °C
W	increases by 8
X	decreases by 6
Y	increases by 9
Z	decreases by 4

Which substances produce the most exothermic and the least endothermic reactions?

	most exothermic	least endothermic
A	W	X
B	W	Z
C	X	Y
D	Y	Z

- 19 The rate of a reaction between a powdered metal and a dilute acid is investigated by measuring the volume of hydrogen gas produced per minute.

The investigation is repeated using a catalyst. The same mass of powdered metal and the same volume and concentration of acid is used.

Which statement about the second investigation is correct?

- A** The rate of the reaction is higher and a greater total volume of hydrogen is produced.
 - B** The rate of the reaction is higher and the same total volume of hydrogen is produced.
 - C** The rate of the reaction is lower and a smaller total volume of hydrogen is produced.
 - D** The rate of the reaction is lower and the same total volume of hydrogen is produced.
- 20 Copper carbonate is reacted with dilute hydrochloric acid.

Which gas is given off?

- A** carbon dioxide
- B** hydrogen
- C** nitrogen
- D** sulfur dioxide

21 Which statement about the halogens is **not** correct?

- A Iodine has a darker colour than chlorine.
- B They all exist as diatomic molecules.
- C They are all gases at room temperature.
- D They are all non-metals.

22 Filament lamps require an inert atmosphere.

Which gas is used to fill these lamps?

- A argon
- B helium
- C hydrogen
- D oxygen

23 Alloys are formed by dissolving one metal in another.

Alloys are1..... .

.....2..... alloys conduct electricity.

Which words complete gaps 1 and 2?

	1	2
A	compounds	All
B	compounds	Some
C	mixtures	All
D	mixtures	Some

24 Metal X is extracted from its ore by heating the ore with carbon.

Which statement explains why carbon is used?

- A Carbon is a non-metal.
- B Carbon is more reactive than X.
- C Carbon reacts with oxygen in the air.
- D Carbon is less reactive than X.

25 Water is tested with white copper(II) sulfate powder and with blue cobalt(II) chloride paper.

Which row shows the results of the tests?

	copper(II) sulfate	cobalt(II) chloride
A	turns blue	stays blue
B	turns blue	turns pink
C	stays white	turns pink
D	stays white	stays blue

26 What is **not** a use of limestone?

- A** manufacture of calcium oxide
- B** neutralising industrial waste products
- C** purifying water
- D** treating acidic soil

27 In which row is the name of the structure correct?

	structure	name
A	$ \begin{array}{c} \text{H} \quad \text{H} \\ \quad \\ \text{C} = \text{C} \\ \quad \\ \text{H} \quad \text{H} \end{array} $	methane
B	$ \begin{array}{c} \text{H} \quad \text{H} \\ \quad \\ \text{H}-\text{C}-\text{C}-\text{O}-\text{H} \\ \quad \\ \text{H} \quad \text{H} \end{array} $	ethene
C	$ \begin{array}{c} \text{H} \quad \text{H} \\ \quad \\ \text{H}-\text{C}-\text{C}-\text{H} \\ \quad \\ \text{H} \quad \text{H} \end{array} $	ethane
D	$ \begin{array}{c} \text{H} \\ \\ \text{H}-\text{C}-\text{H} \\ \\ \text{H} \end{array} $	ethanol

28 The graph shows how the speed of an object varies with time.

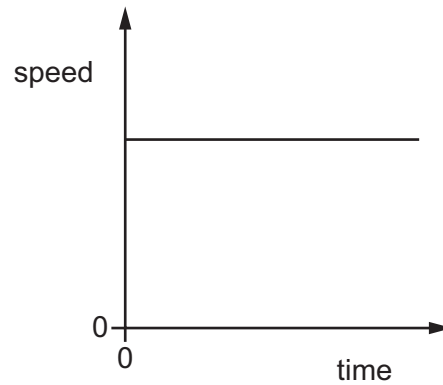

Which graph is the distance–time graph for this object?

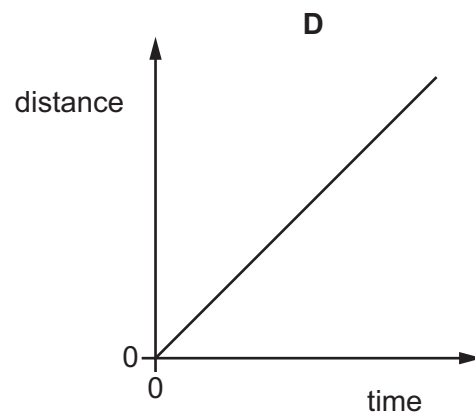
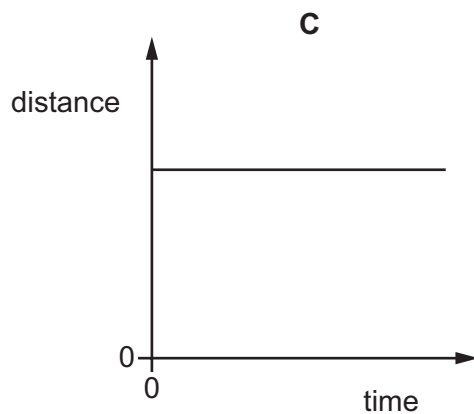
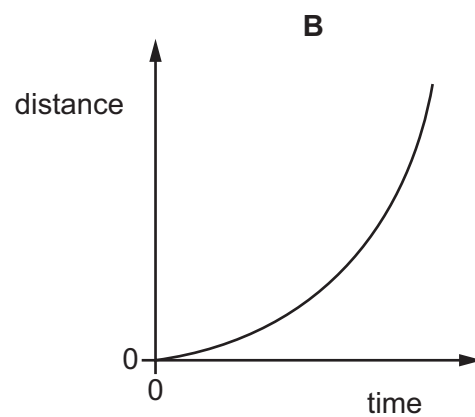
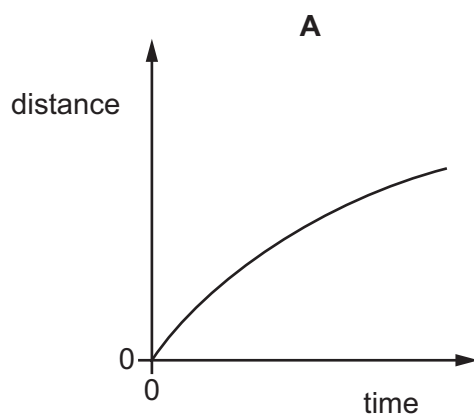

29 Five identical solid glass balls, each of mass 5.0 g, are put into a measuring cylinder containing water.

The water level in the measuring cylinder rises from the 30 cm³ mark to the 40 cm³ mark.

What is the density of the glass from which the balls are made?

- A** 0.50 g/cm³ **B** 1.2 g/cm³ **C** 1.6 g/cm³ **D** 2.5 g/cm³

- 30 A force of 10 N is applied to a beam at a distance of 0.25 m from a pivot.

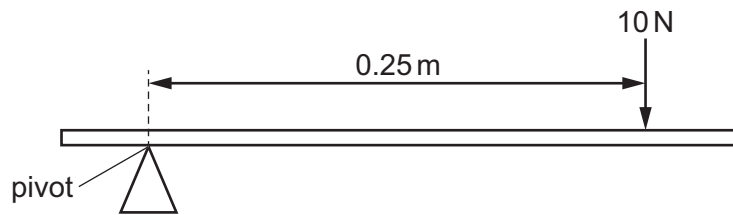

Which calculation gives the moment of the force about the pivot in N m?

- A** 10×0.25 **B** $\frac{10}{0.25}$ **C** $10 + 0.25$ **D** $10 - 0.25$
- 31 Which electrical device transfers chemical energy into electrical energy?
- A** battery
 - B** lamp
 - C** electric motor
 - D** television
- 32 From which type of energy is electrical energy transferred in a hydroelectric power station?
- A** chemical potential energy
 - B** elastic potential (strain) energy
 - C** gravitational potential energy
 - D** nuclear energy

- 33 A hot metal ball is placed in a small hollow in a piece of wood. Two thermometers are placed equal distances from the ball, one at position P and one at position Q.

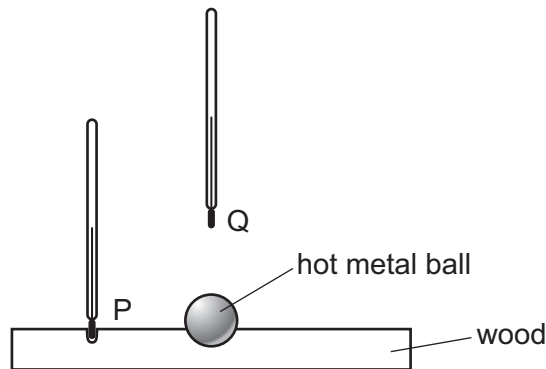

Which thermometer gives the higher reading and why?

	higher reading	reason
A	thermometer at P	the air conducts heat sideways, not upwards
B	thermometer at P	the wood conducts heat sideways, not upwards
C	thermometer at Q	convection carries heat upwards, not sideways
D	thermometer at Q	infrared rays always carry heat upwards, not sideways

- 34 Which description is correct for the image of an object formed by a vertical plane mirror?

- A** upright and larger than the object
- B** upright and the same size as the object
- C** upside down and smaller than the object
- D** upside down and the same size as the object

- 35 Two students conduct an experiment to determine the speed of sound in air.

They stand 639 m apart.

One student hits two blocks of wood together while the other uses a stop-watch to time how long it takes for the sound to reach him.

It takes 1.80 s for the sound to reach the second student.

What is the speed of sound in air, calculated using these results?

- A** 330 m/s
- B** 355 m/s
- C** 710 m/s
- D** 1150 m/s

36 Which type of magnet can be switched on and off many times per second?

- A an electromagnet only
- B a permanent magnet only
- C both electromagnets and permanent magnets
- D neither electromagnets or permanent magnets

37 In which circuit is it possible to change the brightness of one lamp without changing the brightness of the other lamp?

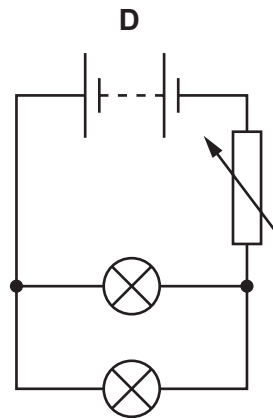
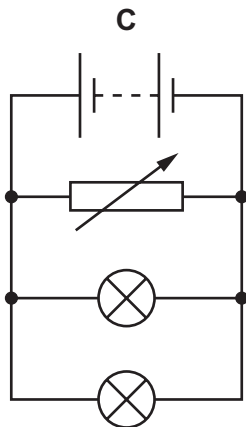
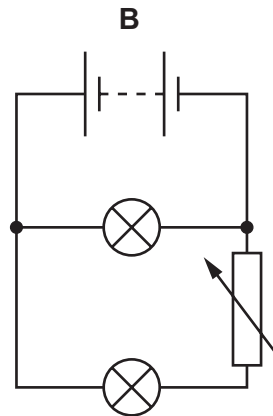
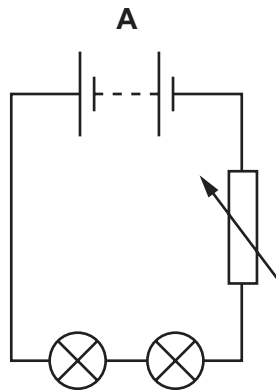

- 38 Circuits 1 and 2 contain identical cells and identical resistors. Each resistor has the same resistance R . The current in the cell in circuit 1 is I .

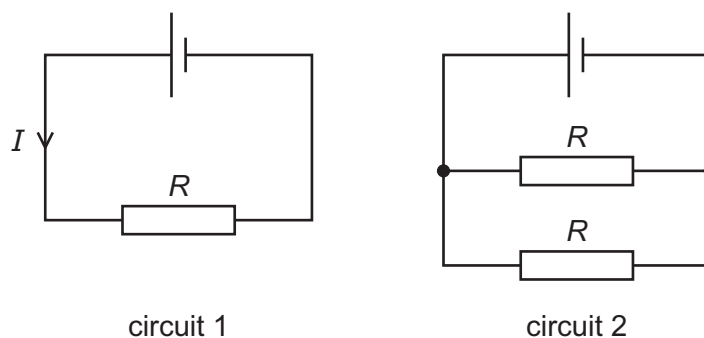

How do the total resistance of circuit 2 and the current in the cell in circuit 2 compare with R and I ?

	total resistance of circuit 2	current in cell in circuit 2
A	greater than R	greater than I
B	greater than R	less than I
C	less than R	greater than I
D	less than R	less than I

- 39 The current in an electric heater during normal use is 11 A.

What is an appropriate rating for a fuse to protect the heater?

- A** 3A **B** 10A **C** 13A **D** 36A

- 40 The diagrams represent pairs of nuclei of some atoms.

Which pair shows nuclei of different isotopes of the same element?

A **B**

C **D**

key
○ neutron
● proton

BLANK PAGE

Permission to reproduce items where third-party owned material protected by copyright is included has been sought and cleared where possible. Every reasonable effort has been made by the publisher (UCLES) to trace copyright holders, but if any items requiring clearance have unwittingly been included, the publisher will be pleased to make amends at the earliest possible opportunity.

To avoid the issue of disclosure of answer-related information to candidates, all copyright acknowledgements are reproduced online in the Cambridge Assessment International Education Copyright Acknowledgements Booklet. This is produced for each series of examinations and is freely available to download at www.cambridgeinternational.org after the live examination series.

Cambridge Assessment International Education is part of Cambridge Assessment. Cambridge Assessment is the brand name of the University of Cambridge Local Examinations Syndicate (UCLES), which is a department of the University of Cambridge.

The Periodic Table of Elements

		Group															
I	II											III	IV	V	VI	VII	VIII
3 Li lithium 7	4 Be beryllium 9	<div style="border: 1px solid black; padding: 5px; text-align: center;"> Key atomic number atomic symbol name relative atomic mass </div>										5 B boron 11	6 C carbon 12	7 N nitrogen 14	8 O oxygen 16	9 F fluorine 19	10 Ne neon 20
11 Na sodium 23	12 Mg magnesium 24											13 Al aluminium 27	14 Si silicon 28	15 P phosphorus 31	16 S sulfur 32	17 Cl chlorine 35.5	18 Ar argon 40
19 K potassium 39	20 Ca calcium 40	21 Sc scandium 45	22 Ti titanium 48	23 V vanadium 51	24 Cr chromium 52	25 Mn manganese 55	26 Fe iron 56	27 Co cobalt 59	28 Ni nickel 59	29 Cu copper 64	30 Zn zinc 65	31 Ga gallium 70	32 Ge germanium 73	33 As arsenic 75	34 Se selenium 79	35 Br bromine 80	36 Kr krypton 84
37 Rb rubidium 85	38 Sr strontium 88	39 Y yttrium 89	40 Zr zirconium 91	41 Nb niobium 93	42 Mo molybdenum 96	43 Tc technetium —	44 Ru ruthenium 101	45 Rh rhodium 103	46 Pd palladium 106	47 Ag silver 108	48 Cd cadmium 112	49 In indium 115	50 Sn tin 119	51 Sb antimony 122	52 Te tellurium 128	53 I iodine 127	54 Xe xenon 131
55 Cs caesium 133	56 Ba barium 137	57–71 lanthanoids	72 Hf hafnium 178	73 Ta tantalum 181	74 W tungsten 184	75 Re rhenium 186	76 Os osmium 190	77 Ir iridium 192	78 Pt platinum 195	79 Au gold 197	80 Hg mercury 201	81 Tl thallium 204	82 Pb lead 207	83 Bi bismuth 209	84 Po polonium —	85 At astatine —	86 Rn radon —
87 Fr francium —	88 Ra radium —	89–103 actinoids	104 Rf rutherfordium —	105 Db dubnium —	106 Sg seaborgium —	107 Bh bohrium —	108 Hs hassium —	109 Mt meitnerium —	110 Ds darmstadtium —	111 Rg roentgenium —	112 Cn copernicium —	114 Fl flerovium —	116 Lv livermorium —	—	—	—	—

lanthanoids	57 La lanthanum 139	58 Ce cerium 140	59 Pr praseodymium 141	60 Nd neodymium 144	61 Pm promethium —	62 Sm samarium 150	63 Eu europium 152	64 Gd gadolinium 157	65 Tb terbium 159	66 Dy dysprosium 163	67 Ho holmium 165	68 Er erbium 167	69 Tm thulium 169	70 Yb ytterbium 173	71 Lu lutetium 175
actinoids	89 Ac actinium —	90 Th thorium 232	91 Pa protactinium 231	92 U uranium 238	93 Np neptunium —	94 Pu plutonium —	95 Am americium —	96 Cm curium —	97 Bk berkelium —	98 Cf californium —	99 Es einsteinium —	100 Fm fermium —	101 Md mendelevium —	102 No nobelium —	103 Lr lawrencium —

The volume of one mole of any gas is 24 dm³ at room temperature and pressure (r.t.p.).