



UNIVERSITY OF CAMBRIDGE INTERNATIONAL EXAMINATIONS
International General Certificate of Secondary Education

CANDIDATE
NAME

CENTRE
NUMBER

--	--	--	--	--

CANDIDATE
NUMBER

--	--	--	--



TWENTY FIRST CENTURY SCIENCE

0608/05

Paper 5

October/November 2011

1 hour 30 minutes

Candidates answer on the Question Paper.

No Additional Materials are required.

READ THESE INSTRUCTIONS FIRST

Write your Centre number, candidate number and name on all the work you hand in.

Write in dark blue or black pen.

You may use a pencil for any diagrams or graphs.

Do not use staples, paper clips, highlighters, glue or correction fluid.

DO NOT WRITE IN ANY BARCODES.

Answer **all** questions.

At the end of the examination, fasten all your work securely together.

The number of marks is given in brackets [] at the end of each question or part question.

For Examiner's Use	
1	
2	
3	
4	
Total	

This document consists of **15** printed pages and **1** blank page.



Section A

Read this newspaper article.

Chocolate is good for your heart

Cardiovascular diseases, which include heart disease, are a major cause of death in many parts of the world. Scientists have found that eating chocolate makes you less likely to suffer from cardiovascular diseases. They investigated the link between eating chocolate and blood pressure. High blood pressure can damage blood vessels which may then lead to heart attacks.

In the first part of the study, scientists monitored the health of 19357 people, aged between 35 and 65, for ten years. At regular intervals throughout the ten year period, people recorded how much chocolate they ate each day.

The second part of the study involved a smaller group of 1568 people. They had their chocolate intake monitored more closely over a 24 hour period. In this second part of the study, 57% ate milk chocolate and 24% ate dark chocolate. Chocolate contains chemicals called flavanols which lower blood pressure. Dark chocolate contains more flavanols.

The results of the whole scientific study, which were published in a peer-reviewed journal, revealed that people who ate 7.5 grams of chocolate a day were 39% less likely to suffer from cardiovascular diseases than people who ate just 1.7 grams of chocolate.

Some scientists believe it is the flavanols in the chocolate that reduce the risk of cardiovascular disease. To test this idea, the effect of the flavanols on cardiovascular disease could be tested against a placebo.

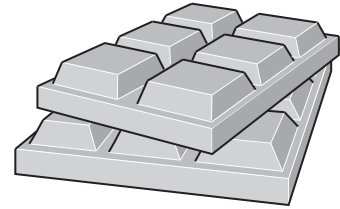

Use information from the article 'Chocolate is good for your heart' to help you answer question 1.

- 1 (a) Heart disease is an example of a cardiovascular disease. Heart disease is often linked to lifestyle factors.

List three lifestyle factors which can cause heart disease.

- 1
- 2
- 3 [3]

- (b) Heart disease may result in a heart attack.

Describe how fatty deposits in an artery may cause a heart attack.

.....
.....
.....
.....
..... [3]

- (c) The article says that the scientific study was published in a peer-reviewed journal.

- (i) What is meant by the term *peer review*?

.....
..... [1]

- (ii) Suggest why peer review is important.

.....
..... [1]

- (iii) Explain why other scientists would want to repeat the study described in the article.

.....
.....
..... [2]

(d) The article states that 1568 people in the study had their chocolate eating monitored for 24 hours.

(i) Using data from the article, calculate the number of these people who ate dark chocolate. Show your working.

number of people who ate dark chocolate = [2]

(ii) Eating dark chocolate may be better at preventing cardiovascular disease than eating milk chocolate. Use information from the article to explain why.

.....
.....
.....
.....
..... [3]

- (e) The article states that "... people who ate 7.5 grams of chocolate a day were 39% more likely to suffer from cardiovascular diseases than people who ate just 1.7 grams of chocolate."

This suggests there is a correlation between eating chocolate and suffering from cardiovascular disease.

- (i) Complete the sentence to describe the correlation:

As the amount of chocolate eaten , the risk of suffering from cardiovascular disease [1]

- (ii) Use the axes to display this correlation.

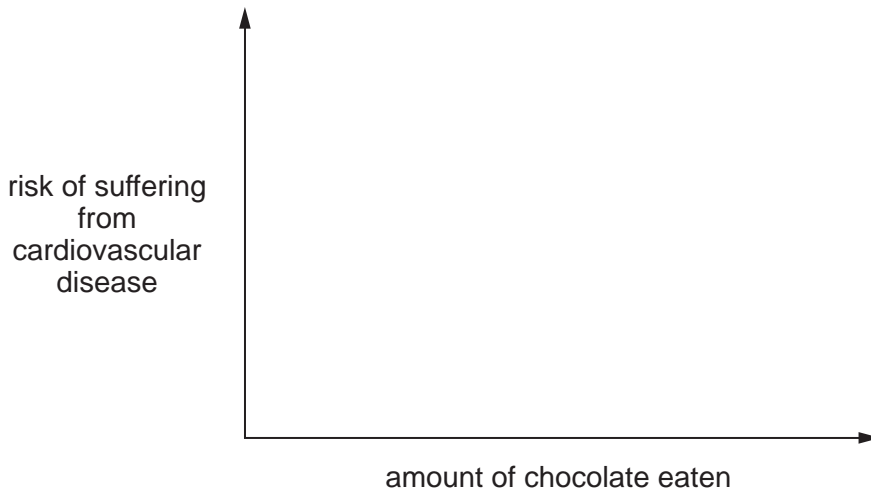

[1]

- (f) In this type of study it is not possible to control all factors that could affect the investigation.

Suggest one factor that could be controlled in the ten-year study.

.....
 [1]

(g) The first part of the study involved 19 357 people over a period of ten years. The second part of the study involved 1568 people over a period of 24 hours.

(i) Explain why some scientists think that the first part of the study is more reliable than the second part.

.....
.....
..... [2]

(ii) Explain why some scientists think that the second part of the study is more reliable than the first part.

.....
.....
..... [2]

(h) The article suggests that the effect of flavanols on cardiovascular disease could be tested against a placebo.

Describe how this test could be carried out.

.....
.....
.....
.....
..... [3]

(i) Eating lots of chocolate can cause you to become overweight, which may lead to serious health problems.

Suggest two reasons why, despite the health risk, some people still choose to eat large amounts of chocolate.

1
2 [2]

(j) Chocolate can be eaten as part of a balanced diet.

Chocolate contains lots of carbohydrate and fat.

Other than carbohydrate and fat, list three components of a balanced diet.

1

2

3 [3]

[Total: 30]

Section B

2 Scientists test the hardness of two polymers, **A** and **B**. They use the apparatus shown in the diagram.

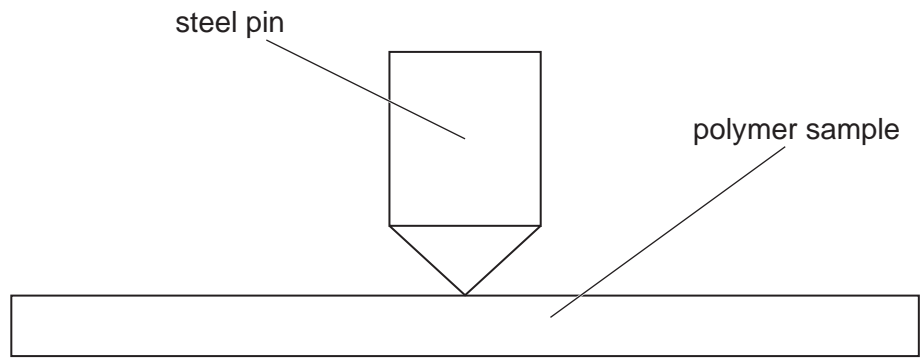

When a force is applied to the pin it sinks into the polymer sample. The diameter of the dent made in the polymer sample is measured.

(a) What apparatus could be used to apply the force to the pin?

Put a ring around the best answer.

- 100 cm³ beaker
 - clamp and stand
 - 1 kg mass
- [1]

(b) The size of the pin and the thickness of the polymer sample must be kept constant.

Explain why these factors must be kept constant.

.....

.....

..... [2]

(c) This diagram shows the dent made in one sample of each polymer.

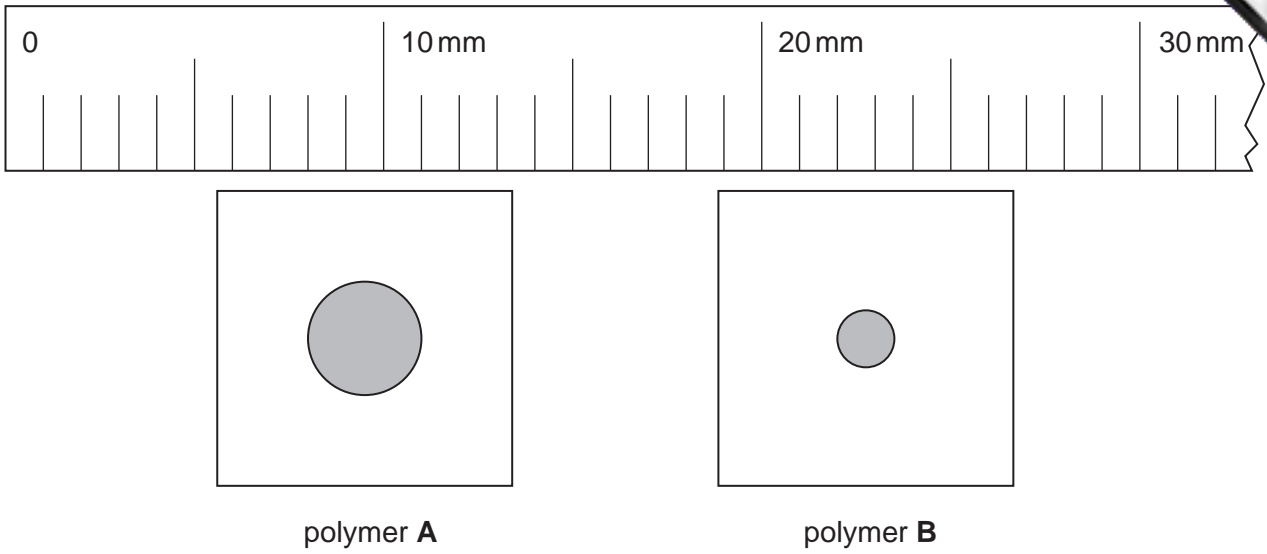

What is the diameter of the dent in

polymer A, mm

polymer B? mm

[2]

(d) The scientists carry out the test on six samples of each polymer. The range and mean of each set of results is shown in the table.

	diameter / mm	
	range	mean
polymer A	2.8 to 3.4	3.2
polymer B	1.0 to 1.8	1.4

(i) What conclusion about the hardness of the two polymers can be made from these results?

.....
..... [1]

(ii) Use ideas about real difference to explain how the results support this conclusion.

.....
.....
..... [2]

10

(iii) One polymer contains a plasticiser and the other does not.

State which polymer has plasticiser and explain how the results show this.

polymer has plasticiser

explanation

..... [2]

[Total: 10]

3 Anya and Julia investigate how a microwave oven heats water.

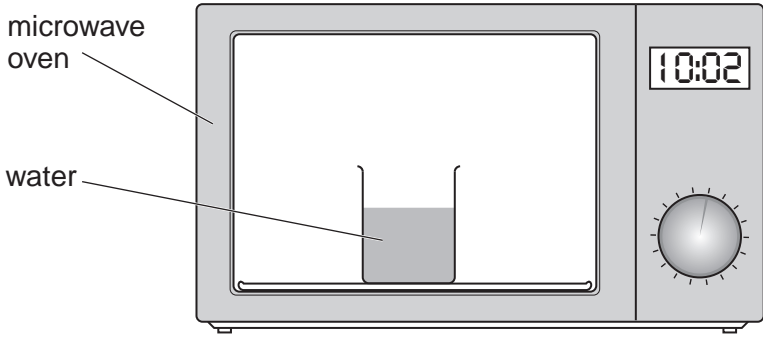

They heat 500 cm³ of water in a beaker in the microwave oven for different periods of time.

(a) Describe how they obtain a set of readings of water temperature.

.....

.....

.....

..... [2]

(b) (i) When they take the beaker out of the microwave oven, Julia realises that the water is hotter at the top of the beaker than it is at the bottom.

What can she do to solve this problem?

.....

..... [1]

(ii) Write down the temperature measurements shown.

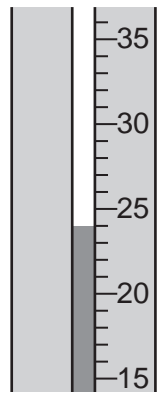
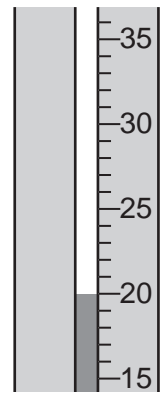

.....°C

.....°C

[1]

(c) Anya and Julia obtain these results.

time/minutes	1	2	3	4	5	6	7	8
temperature/°C	21	28	33	38	44	52	57	63

(i) Plot these points on the graph. Five points have already been plotted.

Draw a straight line of best fit.

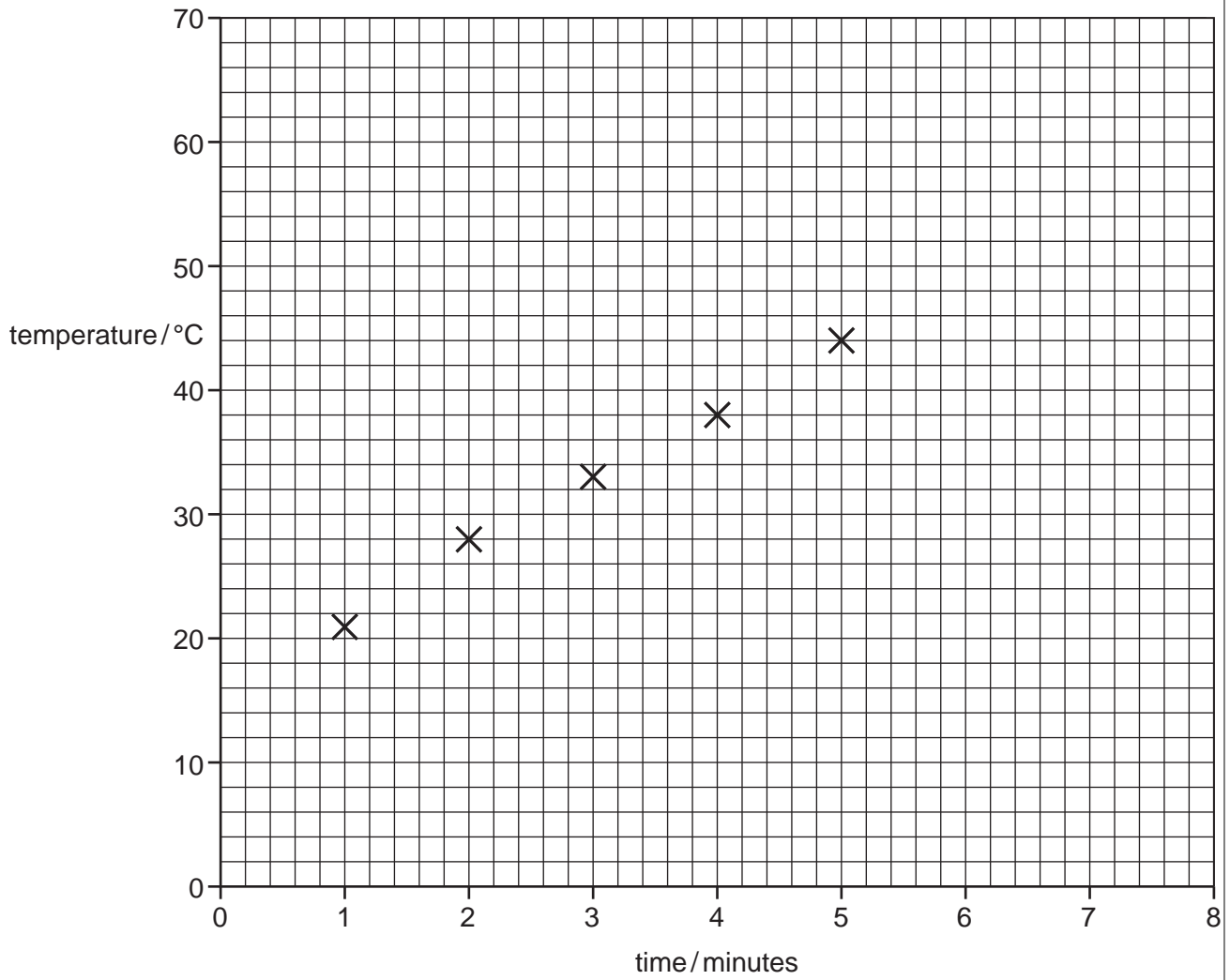

[3]

(ii) Find the intercept of the straight line on the temperature axis.

intercept = °C

Explain what this value means.

.....

..... [2]

(iii) The gradient of the straight line is the rate at which the oven heats the water.

Find this value.

Show your working on the graph.

gradient = °C/minute

[1]

[Total: 10]

4 A group of pupils decide to investigate their reaction times.

They use the following apparatus.

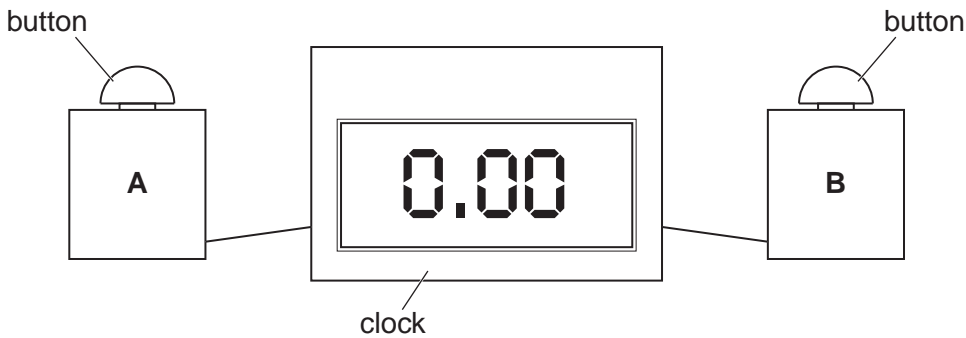

When button **A** is pressed, the clock starts. When button **B** is pressed, the clock stops.

Liz tests the reaction times of three pupils: Ian, Sam and Jay.

As Liz presses button **A**, she touches Ian's arm.

When Ian feels Liz touch his arm, he presses button **B**.

The reading on the clock shows how quickly Ian has reacted to the touch stimulus.

Liz repeats the experiment on Sam and Jay.

(a) Suggest **one** variable that must be controlled in the experiment so that a comparison between Ian, Sam and Jay's reaction times can be made.

.....
..... [1]

(b) Look at their results.

pupil	time taken to stop the clock/seconds					mean
	trial 1	trial 2	trial 3	trial 4	trial 5	
Ian	0.59	0.49	0.47	0.47	0.40	0.48
Sam	0.44	0.38	1.62	0.36	0.30	
Jay	0.48	0.43	0.41	0.40	0.33	0.41

(i) Explain why the experiment was carried out five times for each pupil.

.....

 [2]

(ii) Calculate the mean (average) for Sam's results.

Show your working.

mean (average) = seconds [2]

(c) Look at the range of each set of results. What do these ranges suggest about the accuracy of this method of measuring reaction times?

.....

 [2]

(d) (i) State one additional piece of apparatus that could be used to investigate the pupils' response to a **sound** stimulus.

..... [1]

(ii) Describe how the pupils could carry out this investigation.

.....

 [2]

Permission to reproduce items where third-party owned material protected by copyright is included has been sought and cleared where possible. Every reasonable effort has been made by the publisher (UCLES) to trace copyright holders, but if any items requiring clearance have unwittingly been included, the publisher will be pleased to make amends at the earliest possible opportunity.

University of Cambridge International Examinations is part of the Cambridge Assessment Group. Cambridge Assessment is the brand name of University of